



LEDTECH ELECTRONICS CORP.

: NANYA ROAD,MUGANG ZHAOQING
: CITY GUANGDONG CHINA.
: TEL:86-758-2875541,2870651,2877464,2876185,2877017
: FAX:86-758-2878014
: [Http://www.ledtech.com.tw](http://www.ledtech.com.tw)

SPECIFICATION

PART NO. : LT0323-41-URC4-Z

3.0MM ROUND LED LAMP



Approved by	Checked by	Prepared by
<i>Fang</i>	<i>Long</i>	<i>ChunXiu</i>



3.0MM ROUND LED LAMP
PART NO. : LT0323-41-URC4-Z

Description

This Ture Green lamp is made with InGaN/Sapphire chip and water clear epoxy resin.

Package Dimensions

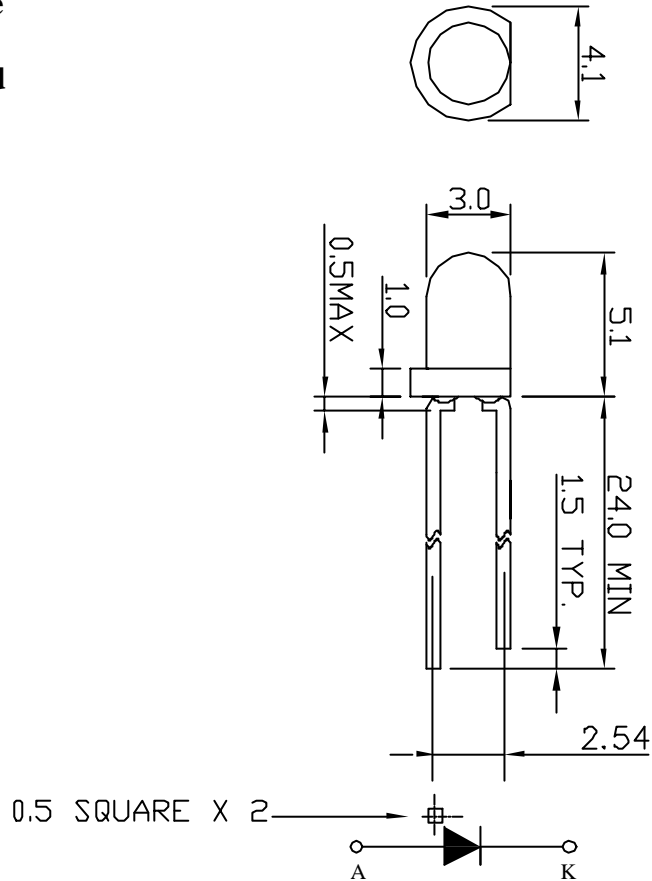

Notes:

- 1.All dimensions are in millimeters.
- 2.Tolerance is ± 0.25 mm unless otherwise noted.

Part No.	LED Chip		Lens Color
	Material	Emitting Color	
LT0323-41-URC4-Z	InGaN/Sapphire	Ture Green	Water clear



3.0MM ROUND LED LAMP
PART NO. : LT0323-41-URC4-Z

Absolute Maximum Ratings at Ta=25 :

Parameter	Symbol	Rating	Unit
Power Dissipation	Pd	120	mW
Reverse Voltage	Vr	5	V
D.C. Forward Current	If	30	mA
Reverse (Leakage) Current	Ir	50	μ A
Peak Current (1/10 Duty Cycle , 0.1 ms Pulse Width)	If(Peak)	100	mA
Operating Temperature Range	Topr	-25 to +85	
Storage Temperature Range	Tstg	-40 to +100	
Lead Soldering Temp.(1.6mm from body) for 5 seconds		260	
Electrostatic discharge (ESD)		6000	V

Electrical and Optical Characteristics :

Parameter	Symbol	Condition	Min.	Typ.	Max.	Unit
Luminous Intensity	Iv	If=20mA	700	1200		mcd
Forward Voltage	Vf	If=20mA		3.2	4.0	V
Dominant Wavelength	D	If=20mA		525		nm
Reverse(Leakage)Current	Ir	Vr=5V			50	μ A
Viewing Angle	2 1/2	If=20mA		24		deg
Spectrum Line Halfwidth		If=20mA		35		nm

NOTE: THE DATAS TESTED BY IS TESTER.



3.0MM ROUND LED LAMP
PART NO. : LT0323-41-URC4-Z

Typical Electrical / Optical Characteristics Curves :

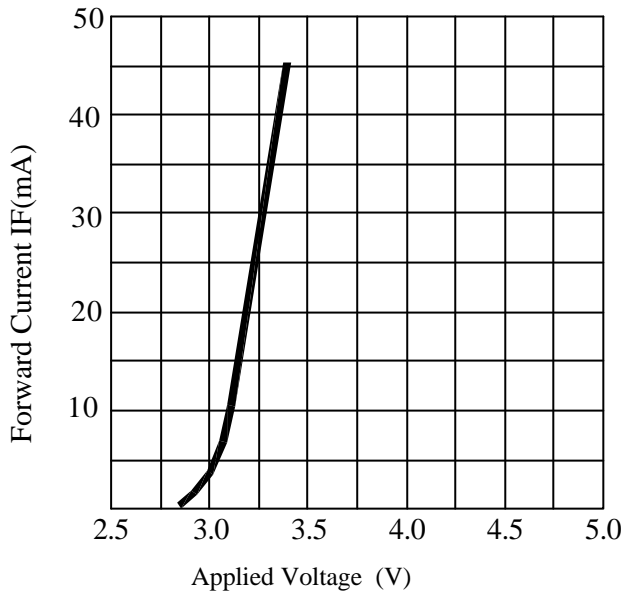

FORWARD CURRENT VS. APPLIED VOLTAGE

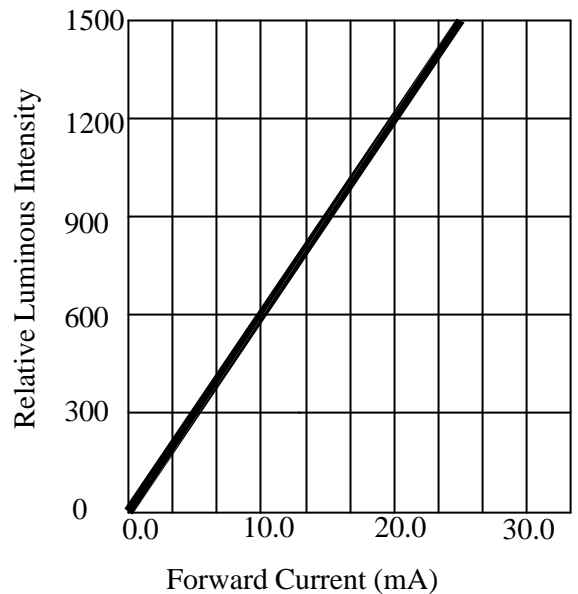

FORWARD CURRENT VS. LUMINOUS INTENSITY

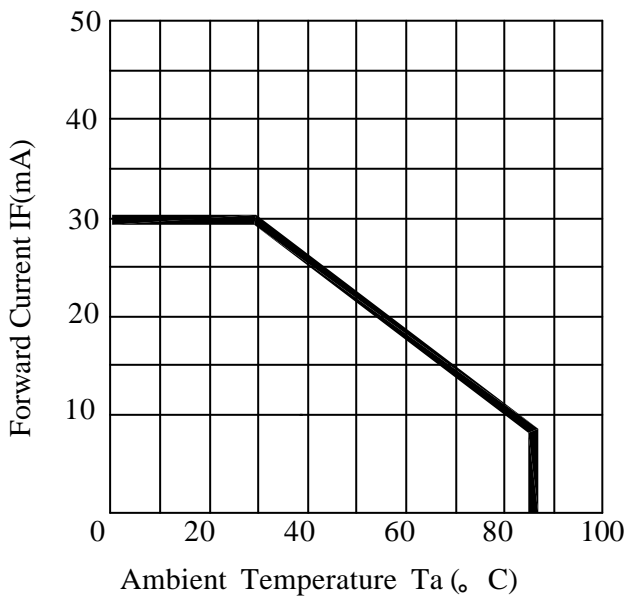

AMBIENT TEMPERATURE VS. FORWARD CURRENT

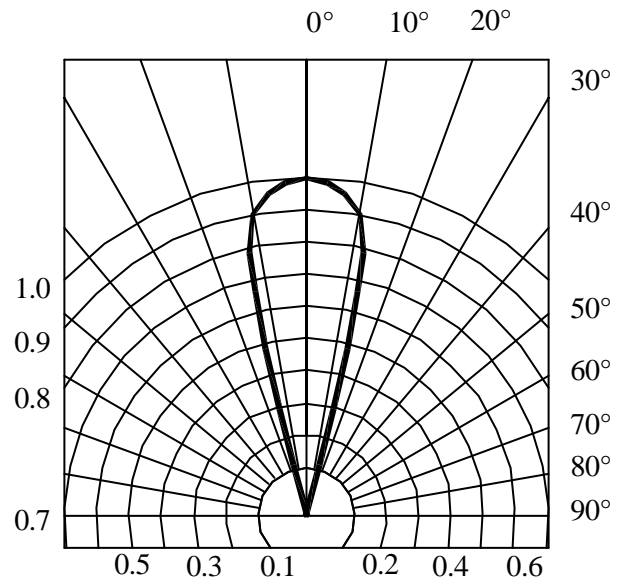

RADIATION DIAGRAM



**3.0MM ROUND LED LAMP
PART NO. : LT0323-41-URC4-Z**

Reliability Test

NO.	Discription	Test Method	Test Condition
1	Operational life	1000 Hrs	IF=20mA, Ta=25 °C
2	High Temp. Storage	1000 Hrs	100 °C
3	Low Temp. Storage	1000 Hrs	-40 °C
4	High Temp./High Humidity	1000 Hrs	60 °C, 95%
5	Temperature Cycling	100 Cycles	-30 °C(30min) → +25 °C(5min) → +80 °C(30min) → +25 °C(5min)
6	Damp Heat Cyclic	40 Cycles Time of 1 cucle: 6 hrs	IF=20mA, Ta=25 °C -0 °C ±(2H) 65 °C ± 90-95%RH(3H) -0 °C ±(1H)
7	Soldering Heat	5 Sec.	260±5°C 1.6mm from bottom of case
8	Solderability	5±0.2 Sec. Wave soldering.	260±5°C Speed of immersing and lifting 25 ±2.5mm/sec
9	Drop	X.Y.Z Direction each 1 time	Maple plate, 75cm
10	Lead pull	10 Sec.	Weight 0.5Kg
11	Lead Bend	2 times	Weight 0.25Kg,Bending Angle=90 °

The result of the above Reliability test will be referred to the Electrical and Optical Characteristic in this Specification and Judgment will be made in accordance with the following criteria listed below.

Reliability Test Failure Judgment Criteria

Item	Criteria for Judgment
Foward Voltage	More than 120 % X upper limit of spec.
Reverse (Leakage) Current	More than 100 % X upper limit of spec.
Luminous Intensity	More than 50 % X Lower limit of spec.
Solderbility	Less than 95 %



3.0MM ROUND LED LAMP PART NO. : LT0323-41-URC4-Z

Page : 5/7

Precautions:

TAKE NOTE OF THE FOLLOWING IN USE OF LED

1. Temperature in use

Since the light generated inside the LED needs to be emitted to outside efficiently, a resin with high light transparency is used; therefore, additives to improve the heat resistance or moisture resistance (silica gel, etc) which are used for semiconductor products such as transistors cannot be added to the resin.

Consequently, the heat resistant ability of the resin used for LED is usually low; therefore, please be careful on the following during use.

Avoid applying external force, stress, and excessive vibration to the resins and terminals at high temperature. The glass transition temperature of epoxy resin used for the LED is approximately 120-130 °C.

At a temperature exceeding this limit, the coefficient of linear expansion of the resin doubles or more compared to that at normal temperature and the resin is softened.

If external force or stress is applied at that time, it may cause a wire rupture.

2. Soldering

Please be careful on the following at soldering.

After soldering, avoid applying external force, stress, and excessive vibration until the products go to cooling process (normal temperature), <Same for products with terminal leads>

(1) Soldering measurements:

Distance between melted solder side to bottom of resin shall be 1.6mm or longer.

(2) Solder dip: Preheat: 90 °C max. (Backside of PCB), Within 120 seconds

Solder bath: 250 °C max. (Solder temperature), Within 5 seconds

(3) Soldering iron : 250 °C max. (Temperature of soldering iron tip), Within 3 seconds

3. Insertion

Pitch of the LED leads and pitch of mounting holes need to be same

4. Others

Since the heat resistant ability of the LED resin is low, SMD components are used on the same PCB, please mount the LED after adhesive baking process for SMD components. In case adhesive baking is done after LED lamp insertion due to a production process reason, make sure not to apply external force, stress, and excessive vibration to the LED and follow the conditions below.

Baking temperature: 120 °C max. Baking time: Within 60 seconds

If soldering is done sequentially after the adhesive baking, please perform the soldering after cooling down the LED to normal temperature.



**3.0MM ROUND LED LAMP
PART NO. :LT0323-41-URC4-Z**

ENCASED TYPE

PLASTIC PACKAGE
QUANTITY: 1,000 PCS

LEDTECH ELECTRONICS CORP.					
PART NO :LTXXXX-XX					
QTY	:	PCS			
LOT NO	:	XXXXXXXXXX			
DATE	:				
BIN CODE:					

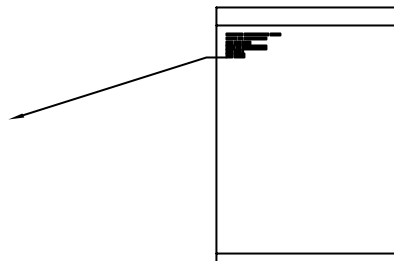

INNER BOX
QUANTITY: 20 PACKETS
TOTAL: 20,000 PCS

PART NO.	LXXXXX-XX-XX				
LOT NO.	XXXXXXXXXX				
BIN CODE	Xx X	Xx X	Xx X	Xx X	TOTAL
QUANTITY	PCS	PCS	PCS	PCS	PCS
DATE	XXXX , XX , XX				

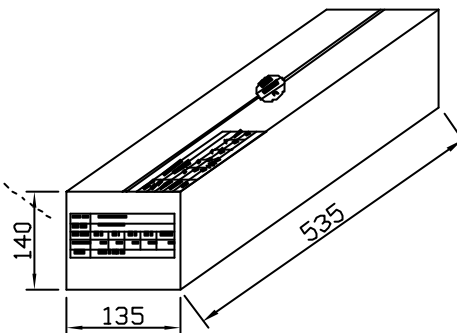

OUTER CARTON
QUANTITY: 4 BOX
TOTAL: 80,000 PCS

C/T NO. 箱 號	XX
PART NO. 料 號	LXXXXX-XX-XX
QUANTITY 數 量	PCS
N.W. 淨 重	KGS
G.W. 毛 重	KGS
REMARK 備 註	

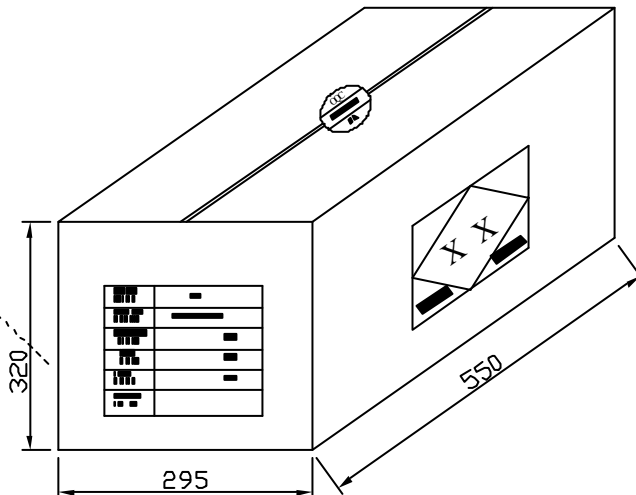



3.0MM ROUND LED LAMP
PART NO. : LT0323-41-URC4-Z

COMPONENT AND MATERIALS:

ITEM		MATERIALS
CUSTOMER PART NO.		
LEDTECH PART NO.		LT0323-41-URC4-Z
LED CHIP		InGaN ON Sapphire
LEADFRAME		Iron covered with Silver
ADHESIVE		SILVER FILLED EPOXY
EPOXY RESIN	RESIN	EPOXY
	HARDENNER	EPOXY
	DIFFUSANT	
	COLORING DYE	
BONDING WIRE		GOLD