

Schnitt D-D

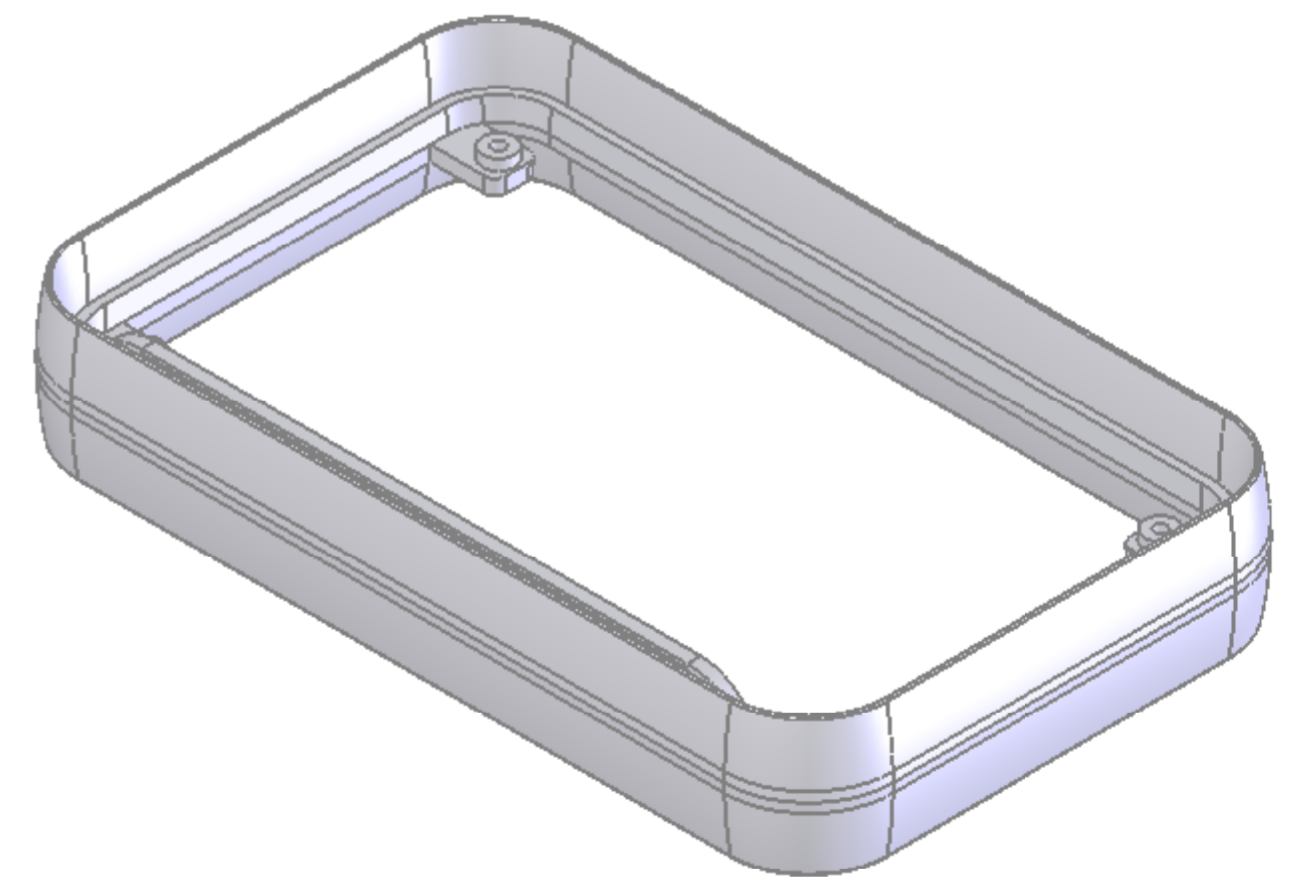
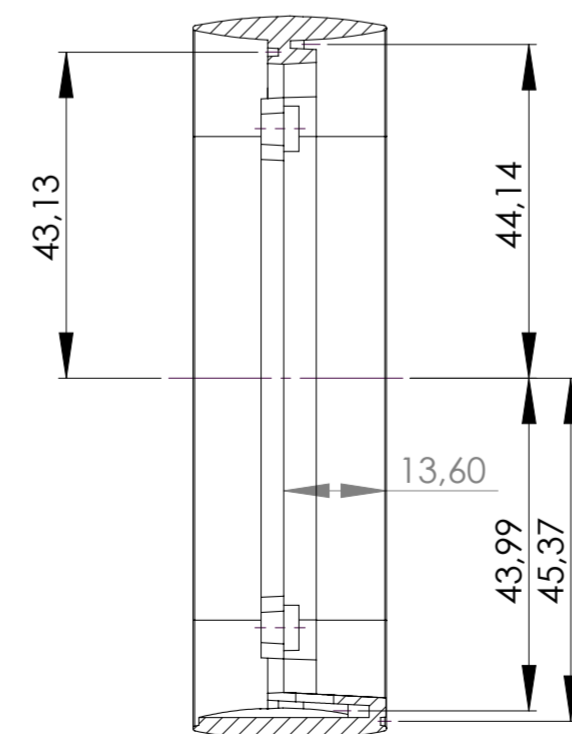

Bearb. am: 13.05.09	Material:	Toleranzen:	
Ersteller: Herrlich	Farbe:	DIN 16901 Teil 130	
Freigabe:	Zeichnungsart:	KUNDE	DIN 6 Teil 2
Rev. Index: 1	Stand:		Maßstab:
		SOFT-CASE XL	1 : 1
		Zwischenring	Bearbeiter:
		A9153001	Altmann
Für dieses Dokument behalten wir uns alle Urheberrechte vor. Es darf auch auszugsweise weder vervielfältigt noch Dritten in irgendeiner Form zugänglich gemacht werden.			Dateiname:
			00011474