

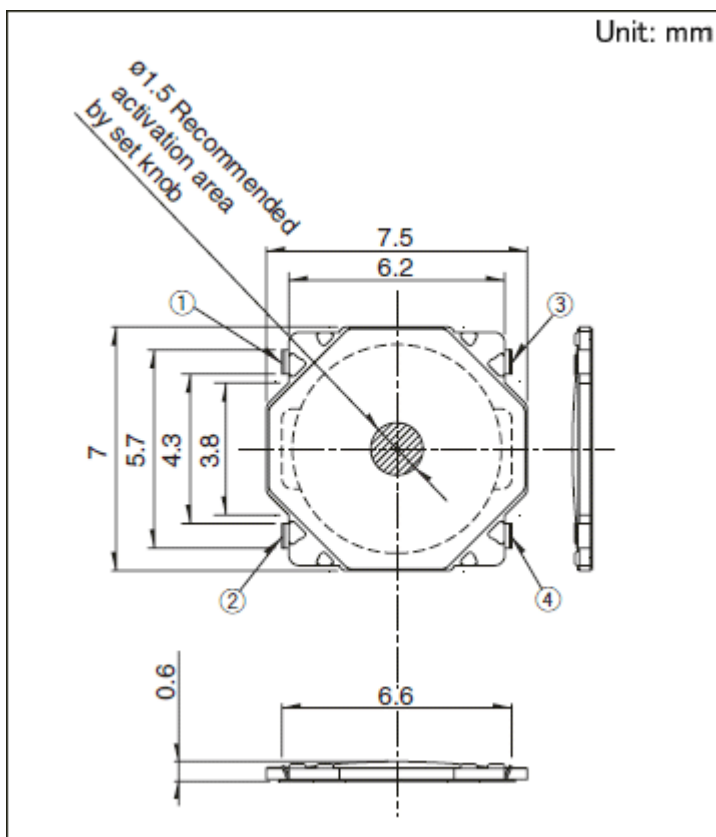

0.6mm Height Low-profile Type with Long-life (Surface Mount) SKRR Series

Part number	SKRRABE010	
Type	Surface mount	
Operating force	1.6N	
Operating direction	Top push	
Travel	0.25mm	
Operating life (5mA 5V DC)	5,000,000 cycles	
Initial contact resistance	500mΩ max.	
Series type	Sharp feeling type	
Operating temperature range	-30°C to +85°C	
Rating (max.)	50mA 12V DC	
Rating (min.)	10μA 1V DC	
Electrical performance	Insulation resistance	100MΩ min. 100V DC for 1min.
	Voltage proof	100V AC for 1 min.
Durability	Vibration	10 to 55 to 10Hz/min., the amplitude is 1.5mm for all the frequencies, in the 3 direction of X, Y and Z for 2 hours respectively
Environmental performance	Cold	-30±2°C for 96h
	Dry heat	80±2°C for 96h
	Damp heat	60±2°C, 90 to 95%RH for 96h
Minimum order unit (pcs.)	Japan	7,000
	Export	7,000

Dimensions



Land Dimensions

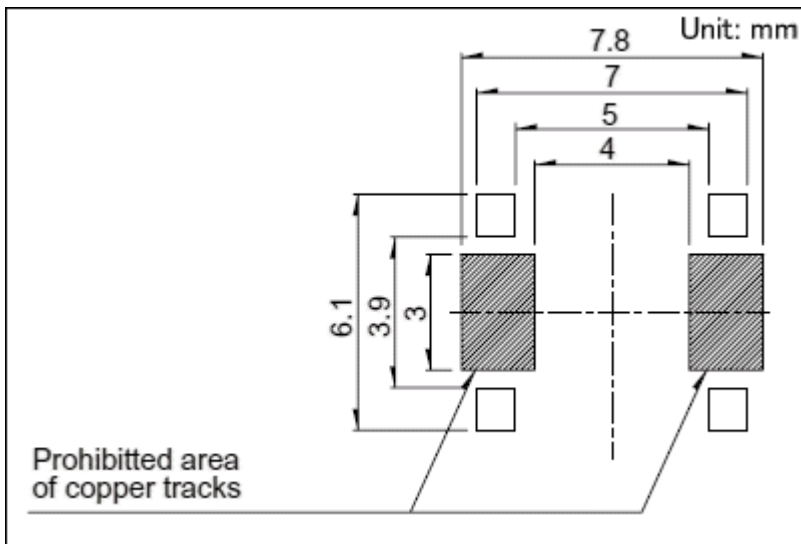

Viewed from mounting face.

Circuit Diagram

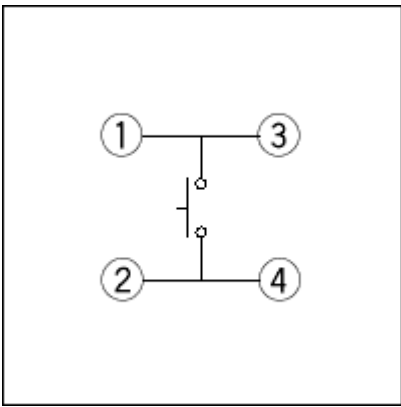

Packing Specifications

Taping

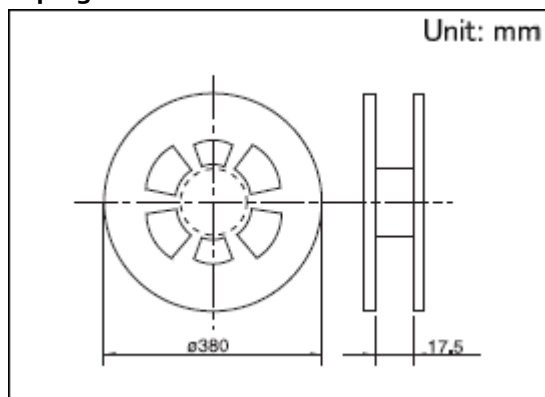

Number of packages 1 reel (pcs.)	7,000
1 case / Japan	56,000
1 case / export packing	56,000
Tape width (mm)	16
Export package measurements (mm)	395×395×205

Soldering Conditions

Condition for Reflow

1. Heating method

Double heating method with infrared heater.

2. Temperature measurement

Thermocouple 0.1 to 0.2 Φ CA(K) or CC(T) at solder joints (copper foil surface). A heat resisting tape should be used for fix measurement.

3. Temperature profile

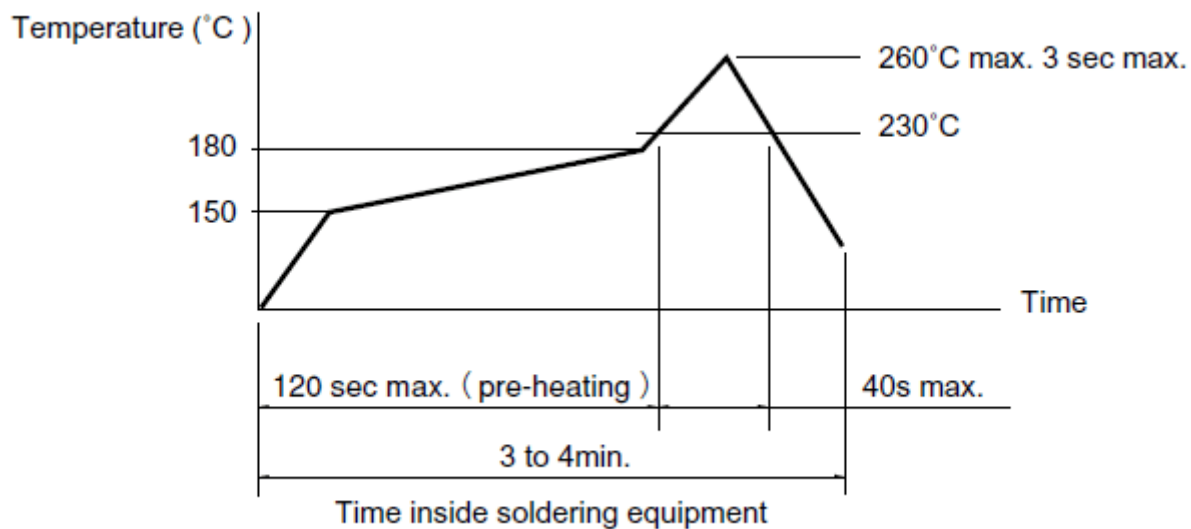

(1) The above temperature shall be measured of the top of switch. There are cases where PC board's temperature greatly differs from that of the switch, depending on the material, size, thickness of PC board's and others. Care, should be taken to prevent the switch's surface temperature from exceeding 260°C.

(2) Soldering conditions differ depending on reflow soldering machines. Prior verification of soldering condition is highly recommended.

Manual Soldering

Items	Condition
Soldering temperature	350°C max.
Duration of soldering	3s max.
Capacity of soldering iron	60W max.

1. Consult with us for availability of TACT switch™ washing.
2. Prevent flux penetration from the top side of the TACT switch™.
3. Switch terminals and a PC board should not be coated with flux prior to soldering.
4. The second soldering should be done after the switch returns to normal temperature.

Notes are common to this series/models.

1. This site catalog shows only outline specifications. When using the products, please obtain formal specifications for supply.
2. Please place purchase orders for taping products per minimum order unit (1 reel or a case).
3. For $\phi 330$ mm diameter reel requirements, please contact us.
4. Please contact us for automotive use products.