

## Metallized Paper (MP) RFI-Capacitors Class Y2 PCM 10 mm and 15 mm

### Special Features

- Particularly high reliability against active and passive flammability
- Excellent self-healing as well as high voltage strength
- High degree of interference suppression due to good attenuation and low ESR
- For temperatures up to +110° C
- According to RoHS 2002/95/EC

### Typical Applications

Class Y2 RFI applications to meet EMC regulations

- Capacitors connected to the mains between phase or neutral and earthed casing
- By-passing of the basic or supplementary insulation, pulse peak voltage  $\leq 5$  kV

### Construction

#### Dielectric:

Paper, epoxy resin impregnated

#### Capacitor electrodes:

Vacuum-deposited

#### Internal construction:

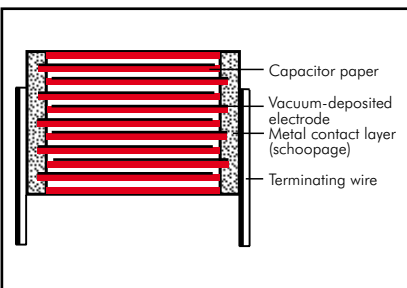

#### Encapsulation:

Self-extinguishing epoxy resin, UL 94 V-0 metal foil

#### Terminations:

Tinned wire.

#### Marking:

Marking: Black on Silver.

### Electrical Data

#### Capacitance range:

1000 pF to 0.022  $\mu$ F (E12-values on request)

#### Rated voltage:

250 VAC

#### Continuous DC voltage\* (general guide):

$\leq 1000$  V

#### Capacitance tolerances:

$\pm 20\%$

#### Operating temperature range:

$-40^{\circ}$  C to  $+110^{\circ}$  C

#### Climatic test category:

40/110/56/C in accordance with IEC

#### Insulation resistance at $+20^{\circ}$ C:

$\geq 12 \times 10^3$  M $\Omega$

Measuring voltage: 100 V/1 min.

#### Dissipation factors:

$\tan \delta \leq 13 \times 10^{-3}$  at 1 kHz and  $+20^{\circ}$  C

#### Test specifications:

In accordance with DIN EN 60384-14

#### Approvals:

Country	Authority	Specification	Symbol	Approval-No.
Germany	VDE	DIN EN 132 400 IEC 60384-14/2		87455
USA	UL	UL 1283		E 100438
Canada	CSA	C 22.2 No. 8		LR 93312-1

\* If safety-approved EMI suppression capacitors are operated with a DC voltage being above the specified AC voltage rating the given approvals are no longer valid (DIN EN 60384-14).

Furthermore the permissible pulse rise time  $du/dt$  ( $F_{max.}$ ) will be subject to a reduction according to

$$F_{max.} = F_r \times \sqrt{2} \times UAC / UDC$$

if the DC operating voltage UDC is higher than  $\sqrt{2} \times UAC$

#### Maximum pulse rise time:

Capacitance pF/ $\mu$ F	Pulse rise time V/ $\mu$ sec max. operation
1000	1100
1500	1100
2200 ... 4700	500
6800 ... 0.022	300

for pulses equal to a voltage amplitude with  $\sqrt{2} \times 250$  VAC = 355 V according to IEC 60384-14

Test voltage: 2700 VDC, 2 sec.

#### Reliability:

Operational life > 300 000 hours

Failure rate < 1 fit ( $0.5 \times U_r$  and  $40^{\circ}$  C)

### Packing

Available taped and reeled.

Detailed taping information and graphs at the end of the catalogue.

For further details and graphs please refer to Technical Information.

## Continuation

### General Data

Capacitance	250 VAC*				PCM**	Part number
	W	H	L			
1000 pF	4	8.5	13.5		10	MPY20W1100FA00_
1500 „	4	8.5	13.5		10	MPY20W1150FA00_
2200 „	4	8.5	13.5		10	MPY20W1220FA00_
3300 „	4	8.5	13.5		10	MPY20W1330FA00_
4700 „	5	10	13.5		10	MPY20W1470FB00_
6800 „	5	13	19		15	MPY20W1680FC00_
0.01 µF	5	13	19		15	MPY20W2100FC00_
0.015 „	6	14	19		15	MPY20W2150FD00_
0.022 „	7	15	19		15	MPY20W2220FE00_

\* f = 50/60 Hz

\*\* PCM = Printed circuit module = lead spacing

Upon request with long leads 35-2 mm max.

Dims. in mm.

Part number completion:

Tolerance: 20 % = M

Packing: bulk = S

Lead length: 6-2 = SD

Taped version see page 140.

d = 0.6 ø if PCM 10  
d = 0.8 ø if PCM 15

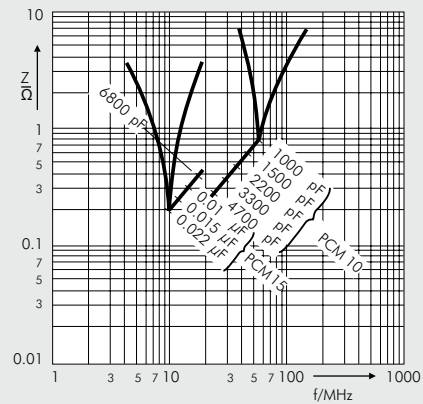
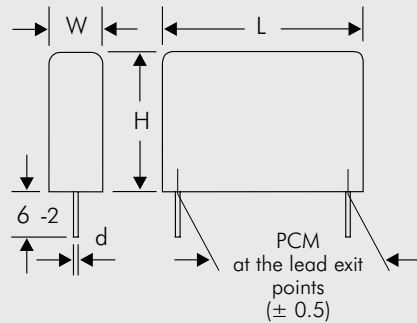

Impedance change with frequency  
(general guide)

Rights reserved to amend design data without prior notification.

## Recommendation for Processing and Application of Through-Hole Capacitors

### Soldering Process

A preheating of through-hole WIMA capacitors is allowed for temperatures  $T_{\max} < 100^{\circ}\text{C}$ . In practice a preheating duration of  $t < 5$  min. has been proven to be best.

#### Single wave soldering

Soldering bath temperature:  $T < 260^{\circ}\text{C}$   
Immersion time:  $t < 5$  sec

#### Double wave soldering

Soldering bath temperature:  $T < 260^{\circ}\text{C}$   
Immersion time:  $2 \times t < 3$  sec

Due to different soldering processes and heat requirements the graphs are to be regarded as a recommendation only.

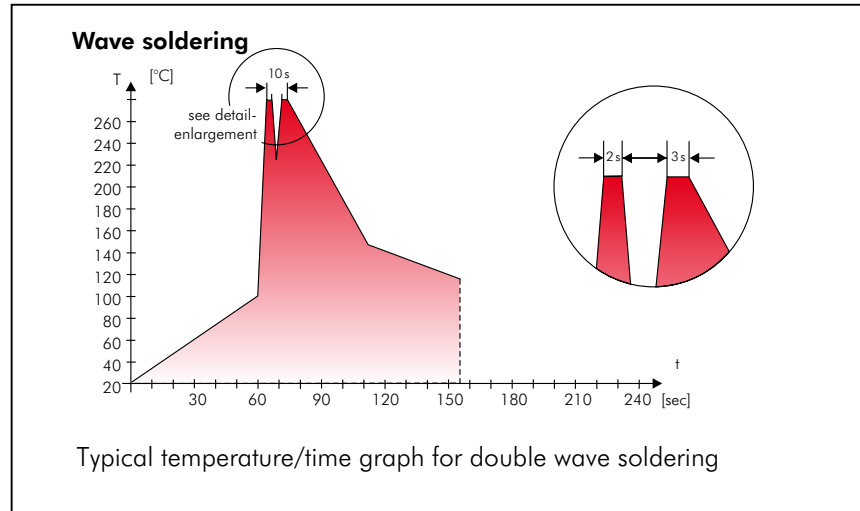

## WIMA Quality and Environmental Philosophy

### ISO 9001:2000 Certification

ISO 9001:2000 is an international basic standard of quality assurance systems for all branches of industry. The approval according to ISO 9001:2000 of our factories by the VDE inspectorate certifies that organisation, equipment and monitoring of quality assurance in our factories correspond to internationally recognized standards.

### WIMA WPCS

The WIMA Process Control System (WPCS) is a quality surveillance and optimization system developed by WIMA. WPCS is a major part of the quality-oriented WIMA production. Points of application of WPCS during production process:

- incoming material inspection
- metallization
- film inspection
- schoopage
- pre-healing
- lead attachment
- cast resin preparation/encapsulation
- 100% final inspection
- AQL check

### WIMA Environmental Policy

All WIMA capacitors, irrespective of whether through-hole devices or SMD, are made of environmentally friendly materials. Neither during manufacture nor in the product itself any toxic substances are used, e.g.

- Lead
- PCB
- CFC
- Hydrocarbon chloride
- Chromium 6+
- PBB/PBDE
- Arsenic
- Cadmium
- Mercury
- etc.

We merely use pure, recyclable materials for packing our components, such as:

- carton
- cardboard
- adhesive tape made of paper
- polystyrene

We almost completely refrain from using packing materials such as:

- foamed polystyrene (Styropor®)
- adhesive tapes made of plastic
- metal clips

### RoHS Compliance

According to the RoHS Directive 2002/95/EC certain hazardous substances like e.g. lead, cadmium, mercury must not be used any longer in electronic equipment as of July 1st, 2006. For the sake of the environment WIMA has refrained from using such substances since years already.



WIMA Kondensatoren sind bleifrei konform RoHS 2002/95/EG

WIMA capacitors are lead free in accordance with RoHS 2002/95/EC

Tape for lead-free WIMA capacitors

### DIN EN ISO 14001:2005

WIMA's environmental management has been established in accordance with the guidelines of DIN EN ISO 14001:2005. The certification has been granted in June 2006.

# Typical Dimensions for Taping Configuration

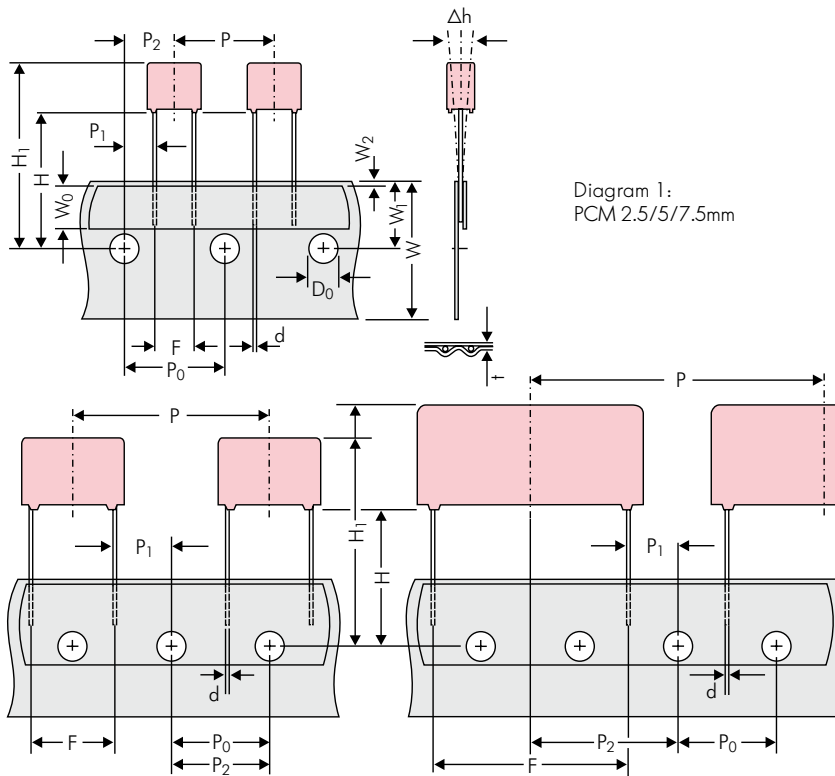

Diagram 2: PCM 10/15 mm

Diagram 3: PCM 22.5 and 27.5\*mm

\*PCM 27.5 tapping possible with two feed holes between components

Designation	Symbol	Dimensions for Radial Taping										
		PCM 2.5 tapping	PCM 5 tapping	PCM 7.5 tapping	PCM 10 tapping*	PCM 15 tapping*	PCM 22.5 tapping	PCM 27.5 tapping				
Carrier tape width	W	18.0 ±0.5	18.0 ±0.5	18.0 ±0.5	18.0 ±0.5	18.0 ±0.5	18.0 ±0.5	18.0 ±0.5				
Hold-down tape width	W <sub>0</sub>	6.0 for hot-sealing adhesive tape	6.0 for hot-sealing adhesive tape	12.0 for hot-sealing adhesive tape	12.0 for hot-sealing adhesive tape	12.0 for hot-sealing adhesive tape	12.0 for hot-sealing adhesive tape	12.0 for hot-sealing adhesive tape				
Hole position	W <sub>1</sub>	9.0 ±0.5	9.0 ±0.5	9.0 ±0.5	9.0 ±0.5	9.0 ±0.5	9.0 ±0.5	9.0 ±0.5				
Hold-down tape position	W <sub>2</sub>	0.5 to 3.0 max.	0.5 to 3.0 max.	0.5 to 3.0 max.	0.5 to 3.0 max.	0.5 to 3.0 max.	0.5 to 3.0 max.	0.5 to 3.0 max.				
Feed hole diameter	D <sub>0</sub>	4.0 ±0.2	4.0 ±0.2	4.0 ±0.2	4.0 ±0.2	4.0 ±0.2	4.0 ±0.2	4.0 ±0.2				
Pitch of component	P	12.7 ±1.0	12.7 ±1.0	12.7 ±1.0	25.4 ±1.0	25.4 ±1.0	38.1 ±1.5	38.1 ±1.5 or 50.8 ±1.5				
Feed hole pitch	P <sub>0</sub>	12.7 ±0.3 cumulative pitch error max. 1.0 mm/20 pitch	12.7 ±0.3 cumulative pitch error max. 1.0 mm/20 pitch	12.7 ±0.3 cumulative pitch error max. 1.0 mm/20 pitch	12.7 ±0.3 cumulative pitch error max. 1.0 mm/20 pitch	12.7 ±0.3 cumulative pitch error max. 1.0 mm/20 pitch	12.7 ±0.3 cumulative pitch error max. 1.0 mm/20 pitch	12.7 ±0.3 cumulative pitch error max. 1.0 mm/20 pitch				
Feed hole centre to lead	P <sub>1</sub>	5.1 ±0.5	3.85 ±0.7	2.6 ±0.7	7.7 ±0.7	5.2 ±0.7	7.8 ±0.7	5.3 ±0.7				
Hole centre to component centre	P <sub>2</sub>	6.35 ±1.3	6.35 ±1.3	6.35 ±1.3	12.7 ±1.3	12.7 ±1.3	19.05 ±1.3	19.05 ±1.3				
Feed hole centre to bottom edge of the component	H	16.5 ±0.3 18.5 ±0.5	16.5 ±0.3 18.5 ±0.5	16.5 ±0.5 18.5 ±0.5	16.5 ±0.5 18.5 ±0.5	16.5 ±0.5 18.5 ±0.5	16.5 ±0.5 18.5 ±0.5	16.5 ±0.5 18.5 ±0.5				
Feed hole centre to top edge of the component	H <sub>1</sub>	H+H <sub>component</sub> < H <sub>1</sub> 32.25 max.	H+H <sub>component</sub> < H <sub>1</sub> 32.25 max.	H+H <sub>component</sub> < H <sub>1</sub> 24.5 to 31.5	H+H <sub>component</sub> < H <sub>1</sub> 25.0 to 31.5	H+H <sub>component</sub> < H <sub>1</sub> 26.0 to 37.0	H+H <sub>component</sub> < H <sub>1</sub> 30.0 to 43.0	H+H <sub>component</sub> < H <sub>1</sub> 35.0 to 45.0				
Lead spacing at upper edge of carrier tape	F	2.5 ±0.5	5.0 <sup>+0.8</sup> <sub>-0.2</sub>	7.5 ±0.8	10.0 ±0.8	15 ±0.8	22.5 ±0.8	27.5 ±0.8				
Lead diameter	d	0.4 ±0.05	0.5 ±0.05	0.5 ±0.05 or 0.6 <sup>+0.06</sup> <sub>-0.05</sub>	0.5 ±0.05 or 0.6 <sup>+0.06</sup> <sub>-0.05</sub>	0.8 <sup>+0.08</sup> <sub>-0.05</sub>	0.8 <sup>+0.08</sup> <sub>-0.05</sub>	0.8 <sup>+0.08</sup> <sub>-0.05</sub>				
Component alignment	Δh	± 2.0 max.	± 2.0 max.	± 3.0 max.	± 3.0 max.	± 3.0 max.	± 3.0 max.	± 3.0 max.				
Total tape thickness	t	0.7 ±0.2	0.7 ±0.2	0.7 ±0.2	0.7 ±0.2	0.7 ±0.2	0.7 ±0.2	0.7 ±0.2				
Package (see also page 141)	ROLL/AMMO			AMMO								
	REEL	φ 360 max. φ 30 ±1	B 52 ±2 58 ±2	depending on comp. dimensions		REEL	φ 360 max. φ 30 ±1	B 52 ±2 58 ±2 or 66 ±2	REEL	φ 500 max. φ 25 ±1	B 60 ±2 68 ±2	depending on PCM and component dimensions
Unit	see details page 143.											

Dims in mm.

\* Diameter of leads see General Data.

Please clarify customer-specific deviations with the manufacturer.

\* PCM 10 and PCM 15 can be crimped to PCM 7.5.

Position of components according to PCM 7.5 (sketch 1). P<sub>0</sub> = 12.7 or 15.0 is possible



# Packing Quantities for Bulk Capacitors and TPS\*

PCM	Size				pcs. per packaging unit bulk			pcs. per packaging unit/TPS*	
	W	H	L	Codes	Mini <b>M</b>	Standard <b>S</b>	Maxi <b>G</b>	Mini <b>X</b>	Standard <b>Y</b>
<b>2.5 mm</b>	2.5	7	4.6	<b>0B</b>	1000	5000	10 000	-	-
	3	7.5	4.6	<b>0C</b>	1000	5000	10 000	-	-
	3.8	8.5	4.6	<b>0D</b>	1000	5000	10 000	-	-
	4.6	9	4.6	<b>0E</b>	1000	5000	10 000	-	-
	5.5	10	4.6	<b>0F</b>	1000	5000	10 000	-	-
<b>5 mm</b>	2.5	6.5	7.2	<b>1A</b>	2000	5000	10 000	-	-
	3	7.5	7.2	<b>1B</b>	1000	5000	-	-	-
	3.5	8.5	7.2	<b>1C</b>	1000	5000	-	-	-
	4.5	6	7.2	<b>1D</b>	1000	6000	-	-	-
	4.5	9.5	7.2	<b>1E</b>	1000	4000	-	-	-
	5	10	7.2	<b>1F</b>	1000	3500	-	-	-
	5.5	7	7.2	<b>1G</b>	1000	4000	-	-	-
	5.5	11.5	7.2	<b>1H</b>	500	2500	-	-	-
	6.5	8	7.2	<b>1I</b>	1000	2500	-	-	-
	7.2	8.5	7.2	<b>1J</b>	500	2500	-	-	-
	7.2	13	7.2	<b>1K</b>	500	2000	-	-	-
	8.5	10	7.2	<b>1L</b>	500	2000	-	-	-
	8.5	14	7.2	<b>1M</b>	500	1500	-	-	-
11	16	7.2	<b>1N</b>	250	1000	-	-	-	
<b>7.5 mm</b>	2.5	7	10	<b>2A</b>	1000	5000	-	-	-
	3	8.5	10	<b>2B</b>	1000	5000	-	-	-
	4	9	10	<b>2C</b>	1000	4000	-	-	-
	4.5	9.5	10.3	<b>2D</b>	1000	3500	-	-	-
	5	10.5	10.3	<b>2E</b>	1000	3000	-	-	-
	5.7	12.5	10.3	<b>2F</b>	500	2000	-	-	-
	7.2	12.5	10.3	<b>2G</b>	500	1500	-	-	-
<b>10 mm</b>	3	9	13	<b>3A</b>	1000	3000	-	-	-
	4	8.5	13.5	<b>3A</b>	500	3000	-	-	-
	4	9	13	<b>3C</b>	1000	3000	-	-	-
	4	9.5	13	<b>3D</b>	1000	3000	-	-	-
	5	10	13.5	<b>3B</b>	500	2000	-	-	-
	5	11	13	<b>3F</b>	1000	3000	-	-	-
	6	12	13	<b>3G</b>	800	2400	-	-	-
	6	12.5	13	<b>3H</b>	800	2400	-	-	-
8	12	13	<b>3I</b>	500	2000	-	-	-	
<b>15 mm</b>	5	11	18	<b>4B</b>	800	2400	-	-	-
	5	13	19	<b>4C</b>	200	1000	-	-	-
	6	12.5	18	<b>4C</b>	500	2000	-	-	-
	6	14	19	<b>4D</b>	250	1000	-	-	-
	7	14	18	<b>4D</b>	400	1600	-	-	-
	7	15	19	<b>4E</b>	250	1000	-	-	-
	8	15	18	<b>4H</b>	400	1200	-	-	-
	8	17	19	<b>4F</b>	100	500	-	-	-
	9	14	18	<b>4F</b>	400	1200	-	-	-
	9	16	18	<b>4J</b>	300	900	-	-	-
	10	18	19	<b>4G</b>	100	500	-	-	-
11	14	18	<b>4M</b>	300	1000	-	-	-	
<b>22.5 mm</b>	5	14	26.5	<b>5A</b>	300	1200	-	-	-
	6	15	26.5	<b>5B</b>	250	1000	-	-	-
	7	16.5	26.5	<b>5D</b>	190	760	-	-	-
	8	20	28	<b>5H</b>	-	-	-	115	690
	8.5	18.5	26.5	<b>5F</b>	-	-	-	220	880
	10	22	28	<b>5I</b>	-	-	-	90	540
	10.5	19	26.5	<b>5G</b>	-	-	-	170	680
	10.5	20.5	26.5	<b>5H</b>	-	-	-	170	680
	11	21	26.5	<b>5I</b>	-	-	-	170	680
12	24	28	<b>5J</b>	-	-	-	75	450	
<b>27.5 mm</b>	9	19	31.5	<b>6A</b>	-	-	-	160	640
	11	21	31.5	<b>6B</b>	-	-	-	136	544
	13	24	31.5	<b>6D</b>	-	-	-	112	448
	13	25	33	<b>6K</b>	-	-	-	56	336
	15	26	31.5	<b>6F</b>	-	-	-	96	384
	15	26	33	<b>6L</b>	-	-	-	48	288
	17	29	31.5	<b>6G</b>	-	-	-	88	176
	17	34.5	31.5	<b>6I</b>	-	-	-	88	176
	20	32	33	<b>6M</b>	-	-	-	36	216
	20	39.5	31.5	<b>6J</b>	-	-	-	36	144
<b>37.5 mm</b>	9	19	41.5	<b>7A</b>	-	-	-	60	480
	11	22	41.5	<b>7B</b>	-	-	-	51	408
	13	24	41.5	<b>7C</b>	-	-	-	84	252
	15	26	41.5	<b>7D</b>	-	-	-	72	144
	17	29	41.5	<b>7E</b>	-	-	-	66	132
	19	32	41.5	<b>7F</b>	-	-	-	54	108
	20	39.5	41.5	<b>7G</b>	-	-	-	27	108
	24	45.5	41.5	<b>7H</b>	-	-	-	21	84

Rights reserved to amend design data without prior notification.  
Samples and pre-production needs on request.

■ Moulded versions.

\* Tray-Packing-System

# Packing Units for Taped Capacitors with Radial Leads



PCM	Size				ROLL		REEL				AMMO			
					H16.5	H18.5	ø 360		ø 500		340 × 340		490 × 370	
	W	H	L	Codes	N	O	F	I	H	J	A	C	B	D
<b>2.5 mm</b>	2.5	7	4.6	<b>0B</b>	2200		2500				2800			
	3	7.5	4.6	<b>0C</b>	2000		2300				2300			
	3.8	8.5	4.6	<b>0D</b>	1500		1800				1800			
	4.6	9	4.6	<b>0E</b>	1200		1500				1500			
	5.5	10	4.6	<b>0F</b>	900		1200				1200			
<b>5 mm</b>	2.5	6.5	7.2	<b>1A</b>	2200		2500				2800			
	3	7.5	7.2	<b>1B</b>	2000		2300				2300			
	3.5	8.5	7.2	<b>1C</b>	1600		2000				2000			
	4.5	6	7.2	<b>1D</b>	1300		1500				1500			
	4.5	9.5	7.2	<b>1E</b>	1300		1500				1500			
	5	10	7.2	<b>1F</b>	1100		1400				1400			
	5.5	7	7.2	<b>1G</b>	1000		1200				1200			
	5.5	11.5	7.2	<b>1H</b>	1000		1200				1200			
	6.5	8	7.2	<b>1I</b>	800		1000				1000			
	7.2	8.5	7.2	<b>1J</b>	700		1000				1000			
	7.2	13	7.2	<b>1K</b>	700		950				1000			
	8.5	10	7.2	<b>1L</b>	600		800				800			
	8.5	14	7.2	<b>1M</b>	600		800				800			
11	16	7.2	<b>1N</b>	500		700				700				
<b>7.5 mm</b>	2.5	7	10	<b>2A</b>	–		2500		4400		2500		–	
	3	8.5	10	<b>2B</b>	–		2200		4300		2300		4150	
	4	9	10	<b>2C</b>	–		1700		3200		1700		3100	
	4.5	9.5	10.3	<b>2D</b>	–		1500		2900		1400		2800	
	5	10.5	10.3	<b>2E</b>	–		1300		2500		1300		–	
	5.7	12.5	10.3	<b>2F</b>	–		1000		2200		1100		–	
	7.2	12.5	10.3	<b>2G</b>	–		900		1800		1000		–	
<b>10 mm</b>	3	9	13	<b>3A</b>	–		1100		2200		–		1900	
	4	8.5	13.5	<b>FA</b>	–		900		1600		–		1450	
	4	9	13	<b>3C</b>	–		900		1600		–		1450	
	4	9.5	13	<b>3D</b>	–		900		1600		–		1400	
	5	10	13.5	<b>FB</b>	–		700		1300		–		1200	
	5	11	13	<b>3F</b>	–		700		1300		–		1200	
	6	12	13	<b>3G</b>	–		550		1100		–		1000	
	6	12.5	13	<b>3H</b>	–		550		1100		–		1000	
8	12	13	<b>3I</b>	–		400		800		–		740		
<b>15 mm</b>	5	11	18	<b>4B</b>	–		600		1200		–		1150	
	5	13	19	<b>FC</b>	–		600		1200		–		1200	
	6	12.5	18	<b>4C</b>	–		500		1000		–		1000	
	6	14	19	<b>FD</b>	–		500		1000		–		1000	
	7	14	18	<b>4D</b>	–		450		900		–		850	
	7	15	19	<b>FE</b>	–		450		900		–		850	
	8	15	18	<b>4H</b>	–		400		800		–		740	
	8	17	19	<b>FF</b>	–		400		800		–		740	
	9	14	18	<b>4F</b>	–		350		700		–		650	
	9	16	18	<b>4J</b>	–		350		700		–		650	
	10	18	19	<b>FG</b>	–		300		650		–		590	
11	14	18	<b>4M</b>	–		300		600		–		540		
<b>22.5 mm</b>	5	14	26.5	<b>5A</b>	–		–		800		–		770	
	6	15	26.5	<b>5B</b>	–		–		700		–		640	
	7	16.5	26.5	<b>5D</b>	–		–		600		–		550	
	8	20	28	<b>FH</b>	–		–		500		–		480	
	8.5	18.5	26.5	<b>5F</b>	–		–		480		–		450	
	10	22	28	<b>FI</b>	–		–		420		–		380	
	10.5	19	26.5	<b>5G</b>	–		–		400		–		360	
	10.5	20.5	26.5	<b>5H</b>	–		–		400		–		360	
	11	21	26.5	<b>5I</b>	–		–		380		–		350	
	12	24	28	<b>FJ</b>	–		–		350		–		310	
<b>27.5 mm</b>	9	19	31.5	<b>6A</b>	–		–		460/340*		–		420	
	11	21	31.5	<b>6B</b>	–		–		380/280*		–		350	
	13	24	31.5	<b>6D</b>	–		–		300		–		290	
	15	26	31.5	<b>6F</b>	–		–		270		–		250	

\* for 2-inch transport pitches.

Samples and pre-production needs 1 packing unit minimum.

■ Moulded versions.

Rights reserved to amend design data without prior notification.



# WIMA Part Number System

A WIMA part number consists of 18 digits and is composed as follows:

- Field 1 - 4: Type description
- Field 5 - 6: Rated voltage
- Field 7 - 10: Capacitance
- Field 11 - 12: Size and PCM
- Field 13 - 14: Special features (e.g. Snubber versions)
- Field 15: Capacitance tolerance
- Field 16: Packing
- Field 17 - 18: Lead length (untaped)

1	2	3	4	5	6	7	8	9	10	11	12	13	14	15	16	17	18
M	K	S	2	C	0	2	1	0	0	1	A	0	0	M	S	S	D
MKS 2				63 VDC		0.01 µF			2.5x6.5x7.2		-		20%	bulk	6-2		

<p><b>Type description:</b></p> <p>SMD-PET = SMDT SMD-PEN = SMDN SMD-PPS = SMDI FKP 02 = FKPO MKS 02 = MKSO FKS 2 = FKS2 FKM 2 = FKM2 FKP 2 = FKP2 MKS 2 = MKS2 MKP 2 = MKP2 MKI 2 = MKI2 FKS 3 = FKS3 FKM 3 = FKM3 FKP 3 = FKP3 MKS 4 = MKS4 MKM 4 = MKM4 MKP 4 = MKP4 MKP 10 = MKP1 FKP 4 = FKP4 FKP 1 = FKP1 MKP-X2 = MKX2 MKP-X2 R = MKXR MKP-Y2 = MKY2 MP 3-X2 = MPX2 MP 3-X1 = MPX1 MP 3-Y2 = MPY2 MP 3R-Y2 = MPRY Snubber MKP = SNMP Snubber FKP = SNFP GTO MKP = GTOM DC-LINK MKP 4 = DCP4 DC-LINK MKP C = DCPC DC-LINK HC = DCH_ SuperCap C = SCSC SuperCap MC = SCMC SuperCap R = SCSR SuperCap MR = SCMR</p>	<p><b>Rated voltage:</b></p> <p>16 VDC = A0 2.5 VDC = A1 4 VDC = A2 14 VDC = A3 28 VDC = A4 40 VDC = A5 5 VDC = A6 50 VDC = B0 63 VDC = C0 100 VDC = D0 160 VDC = E0 250 VDC = F0 400 VDC = G0 450 VDC = H0 600 VDC = I0 630 VDC = J0 700 VDC = K0 800 VDC = L0 850 VDC = M0 900 VDC = N0 1000 VDC = O1 1100 VDC = P0 1200 VDC = Q0 1250 VDC = R0 1500 VDC = S0 1600 VDC = T0 2000 VDC = U0 2500 VDC = V0 3000 VDC = W0 4000 VDC = X0 6000 VDC = Y0 250 VAC = 0W 275 VAC = 1W 300 VAC = 2W 400 VAC = 3W 440 VAC = 4W 500 VAC = 5W</p>	<p><b>Capacitance:</b></p> <p>22 pF = 0022 47 pF = 0047 100 pF = 0100 150 pF = 0150 220 pF = 0220 330 pF = 0330 470 pF = 0470 680 pF = 0680 1000 pF = 1100 1500 pF = 1150 2200 pF = 1220 3300 pF = 1330 4700 pF = 1470 6800 pF = 1680 0.01 µF = 2100 0.022 µF = 2220 0.047 µF = 2470 0.1 µF = 3100 0.22 µF = 3220 0.47 µF = 3470 1 µF = 4100 2.2 µF = 4220 4.7 µF = 4470 10 µF = 5100 22 µF = 5220 47 µF = 5470 100 µF = 6100 220 µF = 6220 1 F = A010 2.5 F = A025 50 F = A500 100 F = B100 110 F = B110 600 F = B600 1200 F = C120</p>	<p><b>Size:</b></p> <p>4.8x3.3x3 Size 1812 = X1 4.8x3.3x4 Size 1812 = X2 5.7x5.1x3.5 Size 2220 = Y1 5.7x5.1x4.5 Size 2220 = Y2 7.2x6.1x3 Size 2824 = T1 7.2x6.1x5 Size 2824 = T2 10.2x7.6x5 Size 4030 = K1 12.7x10.2x6 Size 5040 = V1 15.3x13.7x7 Size 6054 = Q1 2.5x7x4.6 PCM 2.5 = 0B 3x7.5x4.6 PCM 2.5 = 0C 2.5x6.5x7.2 PCM 5 = 1A 3x7.5x7.2 PCM 5 = 1B 2.5x7x10 PCM 7.5 = 2A 3x8.5x10 PCM 7.5 = 2B 3x9x13 PCM 10 = 3A 4x9x13 PCM 10 = 3C 5x11x18 PCM 15 = 4B 6x12.5x18 PCM 15 = 4C 5x14x26.5 PCM 22.5 = 5A 6x15x26.5 PCM 22.5 = 5B 9x19x31.5 PCM 27.5 = 6A 11x21x31.5 PCM 27.5 = 6B 9x19x41.5 PCM 37.5 = 7A 11x22x41.5 PCM 37.5 = 7B 94x49x182 DCH_ = H0 94x77x182 DCH_ = H1</p>	<p><b>Tolerance:</b></p> <p>20% = M 10% = K 5% = J 2.5% = H 1% = E ...</p> <p><b>Packing:</b></p> <p>AMMO H16.5 340x340 = A AMMO H16.5 490x370 = B AMMO H18.5 340x340 = C AMMO H18.5 490x370 = D REEL H16.5 360 = F REEL H16.5 500 = H REEL H18.5 360 = I REEL H18.5 500 = J ROLL H16.5 = N ROLL H18.5 = O BLISTER W12 180 = P BLISTER W12 330 = Q BLISTER W16 330 = R BLISTER W24 330 = T Bulk Mini = M Bulk Standard = S Bulk Maxi = G TPS Mini = X TPS Standard = Y</p>	<p><b>Special features:</b></p> <p>Standard = 00 Version A1 = 1A Version A1.1.1 = 1B Version A1.2 = 1C</p>	<p><b>Lead length (untaped)</b></p> <p>3.5 ±0.5 = C9 6-2 = SD 16-1 = P4</p>
---	---	--	--	--	--	---

The data on this page is not complete and serves only to explain the part number system. Part number information is listed on the pages of the respective WIMA range.