

1 2 3 4 5

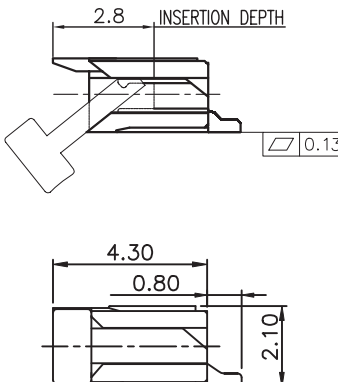
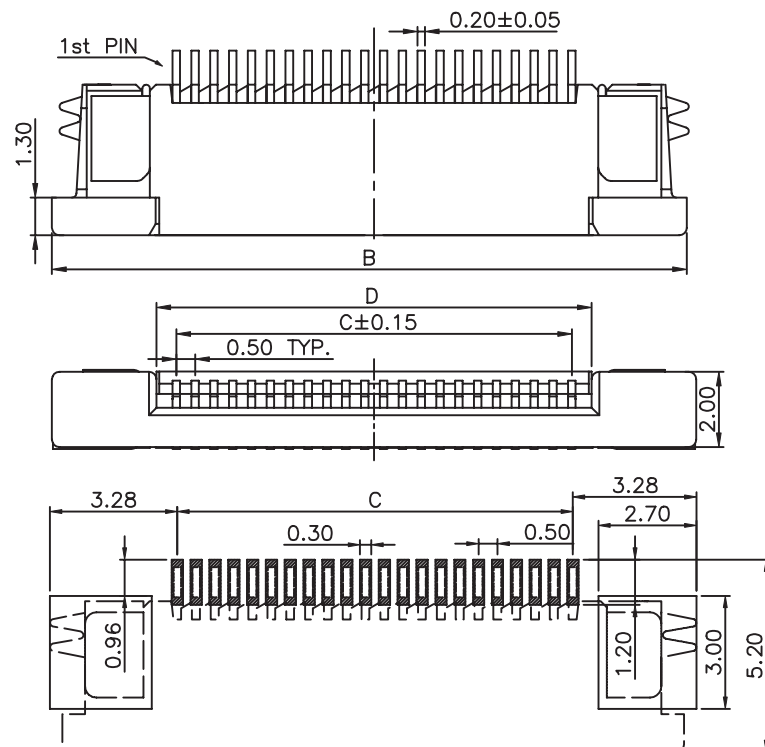

MATERIAL:
 HOUSING MATERIAL: LCP
 COLOR: IVORY
 ACTUATOR MATERIAL: LCP
 COLOR: BLACK
 CONTACT MATERIAL: PHOSPOR BRONZE
 CONTACT PLATING: 100µ TIN OVER 50µ NI
 QUALITY CLASS: 25 MATING CYCLES*

ENVIRONMENTAL:
 OPERATING TEMPERATURE: -25°C UP TO 85°C
 FLAMABILITY RATING: UL94-V0
 COMPLIANCE: LEAD FREE AND ROHS

ELECTRICAL:
 CURRENT RATING: 0.5A
 WORKING VOLTAGE: 50V
 INSULATION RESISTANCE: >100MOHM
 DIELECTRIC WITHSTANDING VOLT.: 250VAC/MN
 CONTACT RESISTANCE: 20mOHM MAX

STANDARD
 AIA CERTIFIED: E323964 / MODEL NUMBER 687
 FOLLOWED BY 1, FOLLOWED BY 04 THRU 50, FOLLOWED
 BY 140 OR 145, FOLLOWED BY NUMERIC DIGITS

SOLDERING:
 REFLOW PROCESS ONLY

DIMENSION:
 B = 0.50 x NB PINS + 6.50
 C = 0.50 x (NB PINS - 1)
 D = 0.50 x (NB PINS + 1) + 0.10
 E = 0.50 x (NB PINS + 1)

RECOMMENDED PCB LAYOUT - COMPONENT VIEW

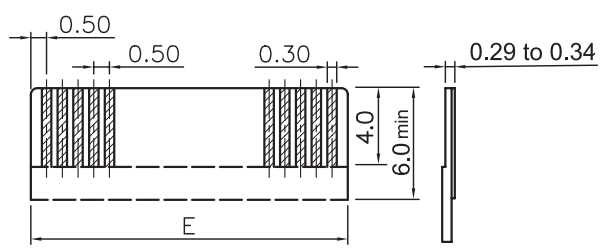

APPLICABLE FFC LAYOUT

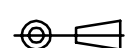
RoHS Compliant		*NOTE: theoretical value related to the Tin plating; however, due to the sensitive actuator, we recommend not to make more than 1 or 2 cycles in order to maintain acceptable mechanical & electrical conditions					
G				PROJECTION:	GENERAL TOLERANCE .X = +/- 0.2 .XX = +/- 0.15 		
F	18-SEP-12	MC NOTE	GG				
E	05-APR-12	LAYOUT	GG				
D	29-APR-11	COPLANARITY	GG				
C	01-FEB-11	NEW PACKAGING	JC	APPROVAL: RJ	UNIT: MM	DESCRIPTION: 0.5MM ZIF FPC HORIZONTAL TOP CONTACT TYPE - TAPE & REEL PACKAGING	SIZE A4
B	21-APR-10	PACKAGING	JP		SCALE:		
A	26-OCT-09	STANDARD	JP		SHEET: 1/3	WERI PART NO: 6871 xx 14022	
REV	DATE	FILE	BY		DRAW: PEARL		

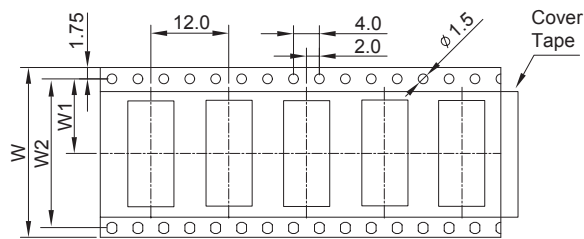
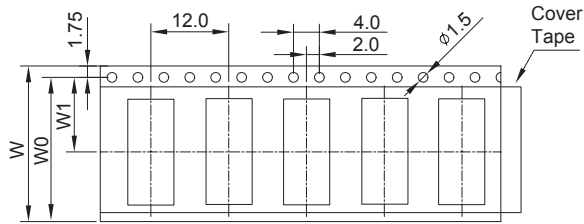
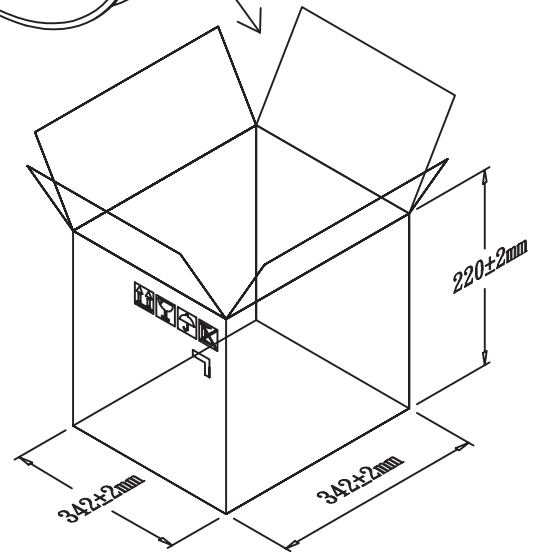
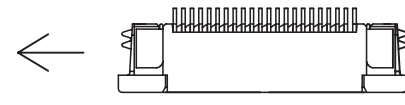
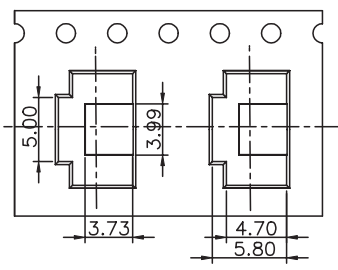
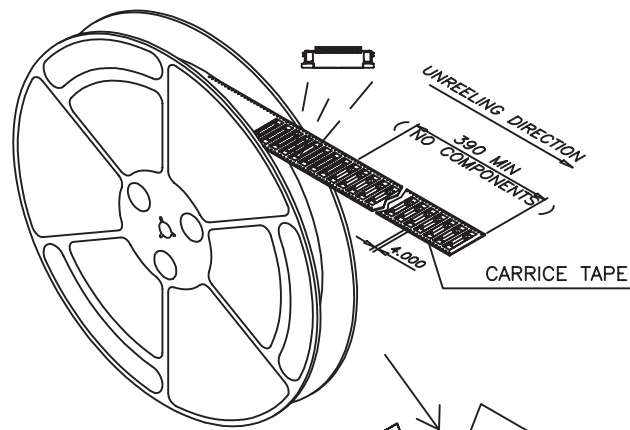

According to EIA Standard

Nb PIN	W 1	W 2	W 3	PH
31 to 50	20.2	40.4	44	12
21 to 31	14.2	28.4	32	12
17 to 20	11.5	24	NA	8
07 to 16	11.5	24	NA	12
04 to 06	7.5	16	NA	12

2000PCS/REEL

NOTE:
 1.10 sprocket hole pitch cumulative tolerance±0.20
 2.Carrier camber is within 1 mm in 100mm
 3.CARTON SIZE : 342*342*220MM

RoHS Compliant				PROJECTION: 	GENERAL TOLERANCE .X = +/- 0.2 .XX = +/- 0.15		DESCRIPTION: 0.5MM ZIF FPC HORIZONTAL TOP CONTACT TYPE - TAPE & REEL PACKAGING WERI PART NO: 6871 xx 14022	SIZE A4
G								
F								
E								
D								
APPROVAL: RJ				UNIT: MM				
				SCALE:				
				SHEET: 2/3				
REV	DATE	FILE	BY	DRAW: PEARL				

