

TOSHIBA Bipolar Linear Integrated Circuit Silicon Monolithic

TA78L05F, TA78L06F, TA78L07F, TA78L08F, TA78L09F, TA78L10F, TA78L12F, TA78L15F, TA78L18F, TA78L20F, TA78L24F

5 V, 6 V, 7 V, 8 V, 9 V, 10 V, 12 V, 15 V, 18 V, 20 V, 24 V

3-Terminal Positive Voltage Regulators

Features

- Best suited to power supply for TTL/CMOS.
- No external parts needed.
- Built-in thermal protective circuit.
- Built-in short-circuit current limiting.
- Max output current of 150mA. ($T_j = 25^\circ\text{C}$).
- Packaged in POWER MINI (SOT-89).

Pin Assignment

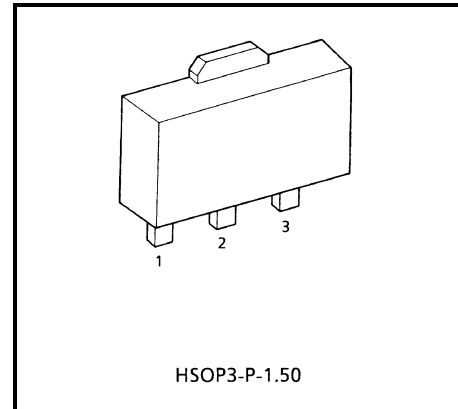
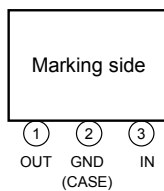

Weight: 0.05 g (Typ.)

Marking

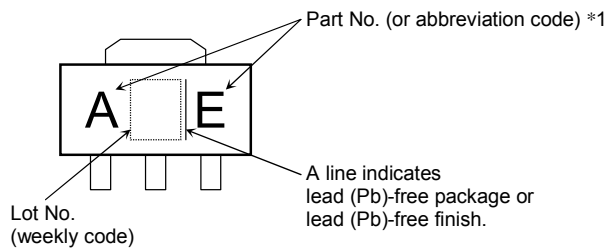

	Part No. (or abbreviation code)	Part No.
	*1	AE
BE		TA78L06F
KE		TA78L07F
CE		TA78L08F
DE		TA78L09F
EE		TA78L10F
FE		TA78L12F
GE		TA78L15F
HE		TA78L18F
IE		TA78L20F
	JE	TA78L24F

Equivalent Circuit

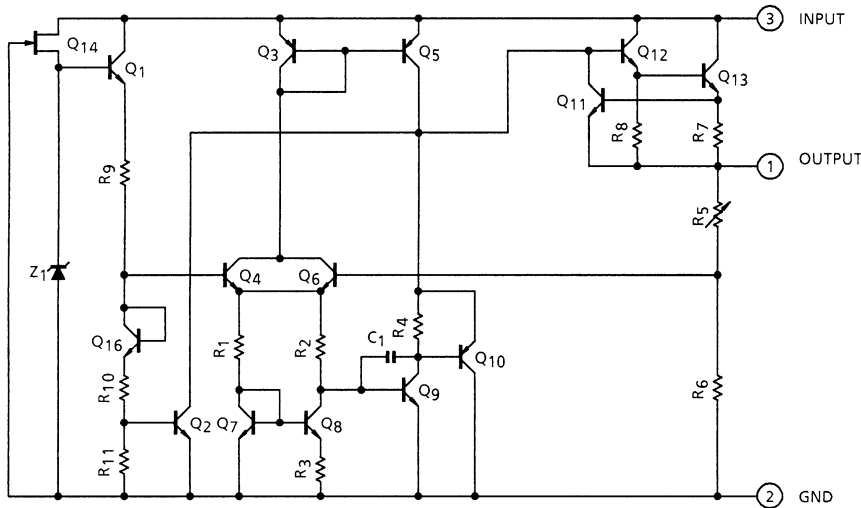

Type	Marking
TA78L05F	AE
TA78L06F	BE
TA78L07F	KE
TA78L08F	CE
TA78L09F	DE
TA78L10F	EE
TA78L12F	FE
TA78L15F	GE
TA78L18F	HE
TA78L20F	IE
TA78L24F	JE

Absolute Maximum Ratings (Ta = 25°C)

Characteristics	Symbol	Rating	Unit	
0Input voltage	V _{IN}	35	V	
				TA78L05F
				TA78L06F
				TA78L07F
				TA78L08F
				TA78L09F
				TA78L10F
				TA78L12F
				TA78L15F
		TA78L18F		
		TA78L20F		
TA78L24F	40			
Power dissipation (Ta = 25°C)	P _D	500	mW	
Power dissipation	P _D	500	mW	
Operating temperature	T _{opr}	-30~85	°C	
Storage temperature	T _{stg}	-55~150	°C	
Junction temperature	T _j	150	°C	
Thermal resistance	R _{th(j-a)}	250	°C/W	

Note: Using continuously under heavy loads (e.g. the application of high temperature/current/voltage and the significant change in temperature, etc.) may cause this product to decrease in the reliability significantly even if the operating conditions (i.e. operating temperature/current/voltage, etc.) are within the absolute maximum ratings and the operating ranges.

Please design the appropriate reliability upon reviewing the Toshiba Semiconductor Reliability Handbook ("Handling Precautions"/Derating Concept and Methods) and individual reliability data (i.e. reliability test report and estimated failure rate, etc).

TA78L05F

Electrical Characteristics

(Unless otherwise specified, $V_{IN} = 10\text{ V}$, $I_{OUT} = 40\text{ mA}$, $C_{IN} = 0.33\text{ }\mu\text{F}$, $C_{OUT} = 0.1\text{ }\mu\text{F}$, $0^\circ\text{C} \leq T_j \leq 125^\circ\text{C}$)

Characteristics	Symbol	Test Circuit	Test Condition	Min	Typ.	Max	Unit	
Output voltage	V_{OUT}	1	$T_j = 25^\circ\text{C}$	4.75	5.0	5.25	V	
Line regulation	Reg.line	1	$T_j = 25^\circ\text{C}$	$7.0\text{ V} \leq V_{IN} \leq 20\text{ V}$	—	55	150	mV
				$8.0\text{ V} \leq V_{IN} \leq 20\text{ V}$	—	45	100	
Load regulation	Reg.load	1	$T_j = 25^\circ\text{C}$	$1.0\text{ mA} \leq I_{OUT} \leq 100\text{ mA}$	—	11	60	mV
				$1.0\text{ mA} \leq I_{OUT} \leq 40\text{ mA}$	—	5.0	30	
Output voltage	V_{OUT}	1	$T_j = 25^\circ\text{C}$	$7.0\text{ V} \leq V_{IN} \leq 20\text{ V}$, $1.0\text{ mA} \leq I_{OUT} \leq 40\text{ mA}$	4.65	—	5.35	V
				$1.0\text{ mA} \leq I_{OUT} \leq 70\text{ mA}$	4.65	—	5.35	
Quiescent current	I_B	1	$T_j = 25^\circ\text{C}$	—	3.1	6.0	mA	
			$T_j = 125^\circ\text{C}$	—	—	5.5		
Quiescent current change	ΔI_B	1	$T_j = 25^\circ\text{C}$	$8.0\text{ V} \leq V_{IN} \leq 20\text{ V}$	—	—	1.5	mA
				$1.0\text{ mA} \leq I_{OUT} \leq 40\text{ mA}$	—	—	0.1	
Output noise voltage	V_{NO}	2	$T_a = 25^\circ\text{C}$, $10\text{ Hz} \leq f \leq 100\text{ kHz}$	—	40	—	μV_{rms}	
Long term stability	$\Delta V_{OUT}/\Delta t$	1	—	—	12	—	mV/kh	
Ripple rejection ratio	R.R.	3	$f = 120\text{ Hz}$, $8.0\text{ V} \leq V_{IN} \leq 18\text{ V}$, $T_j = 25^\circ\text{C}$	41	49	—	dB	
Dropout voltage	V_D	1	$T_j = 25^\circ\text{C}$, $I_{OUT} = 150\text{ mA}$	—	1.7	—	V	
Average temperature coefficient of output voltage	T_{CVO}	1	$I_{OUT} = 5\text{ mA}$	—	-0.6	—	$\text{mV}/^\circ\text{C}$	

TA78L06F

Electrical Characteristics

(Unless otherwise specified, $V_{IN} = 11\text{ V}$, $I_{OUT} = 40\text{ mA}$, $C_{IN} = 0.33\text{ }\mu\text{F}$, $C_{OUT} = 0.1\text{ }\mu\text{F}$, $0^\circ\text{C} \leq T_j \leq 125^\circ\text{C}$)

Characteristics	Symbol	Test Circuit	Test Condition	Min	Typ.	Max	Unit	
Output voltage	V_{OUT}	1	$T_j = 25^\circ\text{C}$	5.7	6.0	6.3	V	
Line regulation	Reg.line	1	$T_j = 25^\circ\text{C}$	$8.1\text{ V} \leq V_{IN} \leq 21\text{ V}$	—	50	150	mV
				$9.0\text{ V} \leq V_{IN} \leq 21\text{ V}$	—	45	110	
Load regulation	Reg.load	1	$T_j = 25^\circ\text{C}$	$1.0\text{ mA} \leq I_{OUT} \leq 100\text{ mA}$	—	12	70	mV
				$1.0\text{ mA} \leq I_{OUT} \leq 40\text{ mA}$	—	5.5	35	
Output voltage	V_{OUT}	1	$T_j = 25^\circ\text{C}$	$8.1\text{ V} \leq V_{IN} \leq 21\text{ V}$, $1.0\text{ mA} \leq I_{OUT} \leq 40\text{ mA}$	5.58	—	6.42	V
				$1.0\text{ mA} \leq I_{OUT} \leq 70\text{ mA}$	5.58	—	6.42	
Quiescent current	I_B	1	$T_j = 25^\circ\text{C}$	—	3.1	6.0	mA	
			$T_j = 125^\circ\text{C}$	—	—	5.5		
Quiescent current change	ΔI_B	1	$T_j = 25^\circ\text{C}$	$9.0\text{ V} \leq V_{IN} \leq 20\text{ V}$	—	—	1.5	mA
				$1.0\text{ mA} \leq I_{OUT} \leq 40\text{ mA}$	—	—	0.1	
Output noise voltage	V_{NO}	2	$T_a = 25^\circ\text{C}$, $10\text{ Hz} \leq f \leq 100\text{ kHz}$	—	40	—	μV_{rms}	
Long term stability	$\Delta V_{OUT}/\Delta t$	1	—	—	14	—	mV/kh	
Ripple rejection ratio	R.R.	3	$f = 120\text{ Hz}$, $9.0\text{ V} \leq V_{IN} \leq 19\text{ V}$, $T_j = 25^\circ\text{C}$	39	47	—	dB	
Dropout voltage	V_D	1	$T_j = 25^\circ\text{C}$, $I_{OUT} = 150\text{ mA}$	—	1.7	—	V	
Average temperature coefficient of output voltage	T_{CVO}	1	$I_{OUT} = 5\text{ mA}$	—	-0.7	—	$\text{mV}/^\circ\text{C}$	

TA78L07F

Electrical Characteristics

(Unless otherwise specified, $V_{IN} = 12\text{ V}$, $I_{OUT} = 40\text{ mA}$, $C_{IN} = 0.33\text{ }\mu\text{F}$, $C_{OUT} = 0.1\text{ }\mu\text{F}$, $0^\circ\text{C} \leq T_j \leq 125^\circ\text{C}$)

Characteristics	Symbol	Test Circuit	Test Condition	Min	Typ.	Max	Unit	
Output voltage	V_{OUT}	1	$T_j = 25^\circ\text{C}$	6.65	7.0	7.35	V	
Line regulation	Reg-line	1	$T_j = 25^\circ\text{C}$	$9.2\text{ V} \leq V_{IN} \leq 22\text{ V}$	—	50	160	mV
				$10\text{ V} \leq V_{IN} \leq 22\text{ V}$	—	45	115	
Load regulation	Reg-load	1	$T_j = 25^\circ\text{C}$	$1.0\text{ mA} \leq I_{OUT} \leq 100\text{ mA}$	—	13	75	mV
				$1.0\text{ mA} \leq I_{OUT} \leq 40\text{ mA}$	—	6.0	40	
Output voltage	V_{OUT}	1	$T_j = 25^\circ\text{C}$	$9.2\text{ V} \leq V_{IN} \leq 22\text{ V}$, $1.0\text{ mA} \leq I_{OUT} \leq 40\text{ mA}$	6.51	—	7.49	V
				$1.0\text{ mA} \leq I_{OUT} \leq 70\text{ mA}$	6.51	—	7.49	
Quiescent current	I_B	1	$T_j = 25^\circ\text{C}$	—	3.1	6.5	mA	
			$T_j = 125^\circ\text{C}$	—	—	6.0		
Quiescent current change	ΔI_B	1	$T_j = 25^\circ\text{C}$	$10\text{ V} \leq V_{IN} \leq 22\text{ V}$	—	—	1.5	mA
				$1.0\text{ mA} \leq I_{OUT} \leq 40\text{ mA}$	—	—	0.1	
Output noise voltage	V_{NO}	2	$T_a = 25^\circ\text{C}$, $10\text{ Hz} \leq f \leq 100\text{ kHz}$	—	50	—	μV_{rms}	
Long term stability	$\Delta V_{OUT}/\Delta t$	1	—	—	17	—	mV/kh	
Ripple rejection ratio	R.R.	3	$f = 120\text{ Hz}$, $10\text{ V} \leq V_{IN} \leq 20\text{ V}$, $T_j = 25^\circ\text{C}$	37	46	—	dB	
Dropout voltage	V_D	1	$T_j = 25^\circ\text{C}$, $I_{OUT} = 150\text{ mA}$	—	1.7	—	V	
Average temperature coefficient of output voltage	T_{CVO}	1	$I_{OUT} = 5\text{ mA}$	—	-0.75	—	$\text{mV}/^\circ\text{C}$	

TA78L08F

Electrical Characteristics

(Unless otherwise specified, $V_{IN} = 14\text{ V}$, $I_{OUT} = 40\text{ mA}$, $C_{IN} = 0.33\text{ }\mu\text{F}$, $C_{OUT} = 0.1\text{ }\mu\text{F}$, $0^\circ\text{C} \leq T_j \leq 125^\circ\text{C}$)

Characteristics	Symbol	Test Circuit	Test Condition	Min	Typ.	Max	Unit	
Output voltage	V_{OUT}	1	$T_j = 25^\circ\text{C}$	7.6	8.0	8.4	V	
Line regulation	Reg.line	1	$T_j = 25^\circ\text{C}$	$10.5\text{ V} \leq V_{IN} \leq 23\text{ V}$	—	20	175	mV
				$11\text{ V} \leq V_{IN} \leq 23\text{ V}$	—	12	125	
Load regulation	Reg.load	1	$T_j = 25^\circ\text{C}$	$1.0\text{ mA} \leq I_{OUT} \leq 100\text{ mA}$	—	15	80	mV
				$1.0\text{ mA} \leq I_{OUT} \leq 40\text{ mA}$	—	7.0	40	
Output voltage	V_{OUT}	1	$T_j = 25^\circ\text{C}$	$10.5\text{ V} \leq V_{IN} \leq 23\text{ V}$, $1.0\text{ mA} \leq I_{OUT} \leq 40\text{ mA}$	7.44	—	8.56	V
				$1.0\text{ mA} \leq I_{OUT} \leq 70\text{ mA}$	7.44	—	8.56	
Quiescent current	I_B	1	$T_j = 25^\circ\text{C}$	—	3.1	6.5	mA	
			$T_j = 125^\circ\text{C}$	—	—	6.0		
Quiescent current change	ΔI_B	1	$T_j = 25^\circ\text{C}$	$11\text{ V} \leq V_{IN} \leq 23\text{ V}$	—	—	1.5	mA
				$1.0\text{ mA} \leq I_{OUT} \leq 40\text{ mA}$	—	—	0.1	
Output noise voltage	V_{NO}	2	$T_a = 25^\circ\text{C}$, $10\text{ Hz} \leq f \leq 100\text{ kHz}$	—	60	—	μV_{rms}	
Long term stability	$\Delta V_{OUT}/\Delta t$	1	—	—	20	—	mV/kh	
Ripple rejection ratio	R.R.	3	$f = 120\text{ Hz}$, $12\text{ V} \leq V_{IN} \leq 23\text{ V}$, $T_j = 25^\circ\text{C}$	37	45	—	dB	
Dropout voltage	V_D	1	$T_j = 25^\circ\text{C}$, $I_{OUT} = 150\text{ mA}$	—	1.7	—	V	
Average temperature coefficient of output voltage	T_{CVO}	1	$I_{OUT} = 5\text{ mA}$	—	-0.8	—	$\text{mV}/^\circ\text{C}$	

TA78L09F

Electrical Characteristics

(Unless otherwise specified, $V_{IN} = 15\text{ V}$, $I_{OUT} = 40\text{ mA}$, $C_{IN} = 0.33\text{ }\mu\text{F}$, $C_{OUT} = 0.1\text{ }\mu\text{F}$, $0^\circ\text{C} \leq T_j \leq 125^\circ\text{C}$)

Characteristics	Symbol	Test Circuit	Test Condition	Min	Typ.	Max	Unit	
Output voltage	V_{OUT}	1	$T_j = 25^\circ\text{C}$	8.55	9.0	9.45	V	
Line regulation	Reg-line	1	$T_j = 25^\circ\text{C}$	$11.4\text{ V} \leq V_{IN} \leq 24\text{ V}$	—	80	200	mV
				$12\text{ V} \leq V_{IN} \leq 24\text{ V}$	—	20	160	
Load regulation	Reg-load	1	$T_j = 25^\circ\text{C}$	$1.0\text{ mA} \leq I_{OUT} \leq 100\text{ mA}$	—	17	90	mV
				$1.0\text{ mA} \leq I_{OUT} \leq 40\text{ mA}$	—	8.0	45	
Output voltage	V_{OUT}	1	$T_j = 25^\circ\text{C}$	$11.4\text{ V} \leq V_{IN} \leq 24\text{ V}$, $1.0\text{ mA} \leq I_{OUT} \leq 40\text{ mA}$	8.37	—	9.63	V
				$1.0\text{ mA} \leq I_{OUT} \leq 70\text{ mA}$	8.37	—	9.63	
Quiescent current	I_B	1	$T_j = 25^\circ\text{C}$	—	3.2	6.5	mA	
			$T_j = 125^\circ\text{C}$	—	—	6.0		
Quiescent current change	ΔI_B	1	$T_j = 25^\circ\text{C}$	$12\text{ V} \leq V_{IN} \leq 24\text{ V}$	—	—	1.5	mA
				$1.0\text{ mA} \leq I_{OUT} \leq 40\text{ mA}$	—	—	0.1	
Output noise voltage	V_{NO}	2	$T_a = 25^\circ\text{C}$, $10\text{ Hz} \leq f \leq 100\text{ kHz}$	—	65	—	μV_{rms}	
Long term stability	$\Delta V_{OUT}/\Delta t$	1	—	—	21	—	mV/kh	
Ripple rejection ratio	R.R.	3	$f = 120\text{ Hz}$, $12\text{ V} \leq V_{IN} \leq 24\text{ V}$, $T_j = 25^\circ\text{C}$	36	44	—	dB	
Dropout voltage	V_D	1	$T_j = 25^\circ\text{C}$, $I_{OUT} = 150\text{ mA}$	—	1.7	—	V	
Average temperature coefficient of output voltage	T_{CVO}	1	$I_{OUT} = 5\text{ mA}$	—	-0.85	—	$\text{mV}/^\circ\text{C}$	

TA78L10F

Electrical Characteristics

(Unless otherwise specified, $V_{IN} = 16\text{ V}$, $I_{OUT} = 40\text{ mA}$, $C_{IN} = 0.33\text{ }\mu\text{F}$, $C_{OUT} = 0.1\text{ }\mu\text{F}$, $0^\circ\text{C} \leq T_j \leq 125^\circ\text{C}$)

Characteristics	Symbol	Test Circuit	Test Condition	Min	Typ.	Max	Unit	
Output voltage	V_{OUT}	1	$T_j = 25^\circ\text{C}$	9.5	10	10.5	V	
Line regulation	Reg-line	1	$T_j = 25^\circ\text{C}$	$12.5\text{ V} \leq V_{IN} \leq 25\text{ V}$	—	80	230	mV
				$13\text{ V} \leq V_{IN} \leq 25\text{ V}$	—	30	170	
Load regulation	Reg-load	1	$T_j = 25^\circ\text{C}$	$1.0\text{ mA} \leq I_{OUT} \leq 100\text{ mA}$	—	18	90	mV
				$1.0\text{ mA} \leq I_{OUT} \leq 40\text{ mA}$	—	8.5	45	
Output voltage	V_{OUT}	1	$T_j = 25^\circ\text{C}$	$12.5\text{ V} \leq V_{IN} \leq 25\text{ V}$, $1.0\text{ mA} \leq I_{OUT} \leq 40\text{ mA}$	9.3	—	10.7	V
				$1.0\text{ mA} \leq I_{OUT} \leq 70\text{ mA}$	9.3	—	10.7	
Quiescent current	I_B	1	$T_j = 25^\circ\text{C}$	—	3.2	6.5	mA	
			$T_j = 125^\circ\text{C}$	—	—	6.0		
Quiescent current change	ΔI_B	1	$T_j = 25^\circ\text{C}$	$13\text{ V} \leq V_{IN} \leq 25\text{ V}$	—	—	1.5	mA
				$1.0\text{ mA} \leq I_{OUT} \leq 40\text{ mA}$	—	—	0.1	
Output noise voltage	V_{NO}	2	$T_a = 25^\circ\text{C}$, $10\text{ Hz} \leq f \leq 100\text{ kHz}$	—	70	—	μV_{rms}	
Long term stability	$\Delta V_{OUT}/\Delta t$	1	—	—	22	—	mV/kh	
Ripple rejection ratio	R.R.	3	$f = 120\text{ Hz}$, $13\text{ V} \leq V_{IN} \leq 24\text{ V}$, $T_j = 25^\circ\text{C}$	36	43	—	dB	
Dropout voltage	V_D	1	$T_j = 25^\circ\text{C}$, $I_{OUT} = 150\text{ mA}$	—	1.7	—	V	
Average temperature coefficient of output voltage	T_{CVO}	1	$I_{OUT} = 5\text{ mA}$	—	-0.9	—	$\text{mV}/^\circ\text{C}$	

TA78L12F

Electrical Characteristics

(Unless otherwise specified, $V_{IN} = 19\text{ V}$, $I_{OUT} = 40\text{ mA}$, $C_{IN} = 0.33\text{ }\mu\text{F}$, $C_{OUT} = 0.1\text{ }\mu\text{F}$, $0^\circ\text{C} \leq T_j \leq 125^\circ\text{C}$)

Characteristics	Symbol	Test Circuit	Test Condition	Min	Typ.	Max	Unit	
Output voltage	V_{OUT}	1	$T_j = 25^\circ\text{C}$	11.4	12	12.6	V	
Line regulation	Reg-line	1	$T_j = 25^\circ\text{C}$	$14.5\text{ V} \leq V_{IN} \leq 27\text{ V}$	—	120	250	mV
				$16\text{ V} \leq V_{IN} \leq 27\text{ V}$	—	100	200	
Load regulation	Reg-load	1	$T_j = 25^\circ\text{C}$	$1.0\text{ mA} \leq I_{OUT} \leq 100\text{ mA}$	—	20	100	mV
				$1.0\text{ mA} \leq I_{OUT} \leq 40\text{ mA}$	—	10	50	
Output voltage	V_{OUT}	1	$T_j = 25^\circ\text{C}$	$14.5\text{ V} \leq V_{IN} \leq 27\text{ V}$, $1.0\text{ mA} \leq I_{OUT} \leq 40\text{ mA}$	11.16	—	12.84	V
				$1.0\text{ mA} \leq I_{OUT} \leq 70\text{ mA}$	11.16	—	12.84	
Quiescent current	I_B	1	$T_j = 25^\circ\text{C}$	—	3.2	6.5	mA	
			$T_j = 125^\circ\text{C}$	—	—	6.0		
Quiescent current change	ΔI_B	1	$T_j = 25^\circ\text{C}$	$16\text{ V} \leq V_{IN} \leq 27\text{ V}$	—	—	1.5	mA
				$1.0\text{ mA} \leq I_{OUT} \leq 40\text{ mA}$	—	—	0.1	
Output noise voltage	V_{NO}	2	$T_a = 25^\circ\text{C}$, $10\text{ Hz} \leq f \leq 100\text{ kHz}$	—	80	—	μV_{rms}	
Long term stability	$\Delta V_{OUT}/\Delta t$	1	—	—	24	—	mV/kh	
Ripple rejection ratio	R.R.	3	$f = 120\text{ Hz}$, $15\text{ V} \leq V_{IN} \leq 25\text{ V}$, $T_j = 25^\circ\text{C}$	36	41	—	dB	
Dropout voltage	V_D	1	$T_j = 25^\circ\text{C}$, $I_{OUT} = 150\text{ mA}$	—	1.7	—	V	
Average temperature coefficient of output voltage	T_{CVO}	1	$I_{OUT} = 5\text{ mA}$	—	-1.0	—	$\text{mV}/^\circ\text{C}$	

TA78L15F

Electrical Characteristics

(Unless otherwise specified, $V_{IN} = 23\text{ V}$, $I_{OUT} = 40\text{ mA}$, $C_{IN} = 0.33\text{ }\mu\text{F}$, $C_{OUT} = 0.1\text{ }\mu\text{F}$, $0^\circ\text{C} \leq T_j \leq 125^\circ\text{C}$)

Characteristics	Symbol	Test Circuit	Test Condition	Min	Typ.	Max	Unit	
Output voltage	V_{OUT}	1	$T_j = 25^\circ\text{C}$	14.25	15	15.75	V	
Line regulation	Reg-line	1	$T_j = 25^\circ\text{C}$	$17.5\text{ V} \leq V_{IN} \leq 30\text{ V}$	—	130	300	mV
				$20\text{ V} \leq V_{IN} \leq 30\text{ V}$	—	110	250	
Load regulation	Reg-load	1	$T_j = 25^\circ\text{C}$	$1.0\text{ mA} \leq I_{OUT} \leq 100\text{ mA}$	—	25	150	mV
				$1.0\text{ mA} \leq I_{OUT} \leq 40\text{ mA}$	—	12	75	
Output voltage	V_{OUT}	1	$T_j = 25^\circ\text{C}$	$17.5\text{ V} \leq V_{IN} \leq 30\text{ V}$, $1.0\text{ mA} \leq I_{OUT} \leq 40\text{ mA}$	13.95	—	16.05	V
				$1.0\text{ mA} \leq I_{OUT} \leq 70\text{ mA}$	13.95	—	16.05	
Quiescent current	I_B	1	$T_j = 25^\circ\text{C}$	—	3.3	6.5	mA	
			$T_j = 125^\circ\text{C}$	—	—	6.0		
Quiescent current change	ΔI_B	1	$T_j = 25^\circ\text{C}$	$20\text{ V} \leq V_{IN} \leq 30\text{ V}$	—	—	1.5	mA
				$1.0\text{ mA} \leq I_{OUT} \leq 40\text{ mA}$	—	—	0.1	
Output noise voltage	V_{NO}	2	$T_a = 25^\circ\text{C}$, $10\text{ Hz} \leq f \leq 100\text{ kHz}$	—	90	—	μV_{rms}	
Long term stability	$\Delta V_{OUT}/\Delta t$	1	—	—	30	—	mV/kh	
Ripple rejection ratio	R.R.	3	$f = 120\text{ Hz}$, $18.5\text{ V} \leq V_{IN} \leq 28.5\text{ V}$, $T_j = 25^\circ\text{C}$	34	40	—	dB	
Dropout voltage	V_D	1	$T_j = 25^\circ\text{C}$, $I_{OUT} = 150\text{ mA}$	—	1.7	—	V	
Average temperature coefficient of output voltage	T_{CVO}	1	$I_{OUT} = 5\text{ mA}$	—	-1.3	—	$\text{mV}/^\circ\text{C}$	

TA78L18F

Electrical Characteristics

(Unless otherwise specified, $V_{IN} = 27\text{ V}$, $I_{OUT} = 40\text{ mA}$, $C_{IN} = 0.33\text{ }\mu\text{F}$, $C_{OUT} = 0.1\text{ }\mu\text{F}$, $0^\circ\text{C} \leq T_j \leq 125^\circ\text{C}$)

Characteristics	Symbol	Test Circuit	Test Condition	Min	Typ.	Max	Unit	
Output voltage	V_{OUT}	1	$T_j = 25^\circ\text{C}$	17.1	18	18.9	V	
Line regulation	Reg-line	1	$T_j = 25^\circ\text{C}$	$21.4\text{ V} \leq V_{IN} \leq 33\text{ V}$	—	32	325	mV
				$22\text{ V} \leq V_{IN} \leq 33\text{ V}$	—	27	275	
Load regulation	Reg-load	1	$T_j = 25^\circ\text{C}$	$1.0\text{ mA} \leq I_{OUT} \leq 100\text{ mA}$	—	30	170	mV
				$1.0\text{ mA} \leq I_{OUT} \leq 40\text{ mA}$	—	15	75	
Output voltage	V_{OUT}	1	$T_j = 25^\circ\text{C}$	$21.4\text{ V} \leq V_{IN} \leq 33\text{ V}$, $1.0\text{ mA} \leq I_{OUT} \leq 40\text{ mA}$	16.74	—	19.26	V
				$1.0\text{ mA} \leq I_{OUT} \leq 70\text{ mA}$	16.74	—	19.26	
Quiescent current	I_B	1	$T_j = 25^\circ\text{C}$	—	3.3	6.5	mA	
			$T_j = 125^\circ\text{C}$	—	—	6.0		
Quiescent current change	ΔI_B	1	$T_j = 25^\circ\text{C}$	$22\text{ V} \leq V_{IN} \leq 33\text{ V}$	—	—	1.5	mA
				$1.0\text{ mA} \leq I_{OUT} \leq 40\text{ mA}$	—	—	0.1	
Output noise voltage	V_{NO}	2	$T_a = 25^\circ\text{C}$, $10\text{ Hz} \leq f \leq 100\text{ kHz}$	—	150	—	μV_{rms}	
Long term stability	$\Delta V_{OUT}/\Delta t$	1	—	—	45	—	mV/kh	
Ripple rejection ratio	R.R.	3	$f = 120\text{ Hz}$, $23\text{ V} \leq V_{IN} \leq 33\text{ V}$, $T_j = 25^\circ\text{C}$	32	38	—	dB	
Dropout voltage	V_D	1	$T_j = 25^\circ\text{C}$, $I_{OUT} = 150\text{ mA}$	—	1.7	—	V	
Average temperature coefficient of output voltage	T_{CVO}	1	$I_{OUT} = 5\text{ mA}$	—	-1.5	—	$\text{mV}/^\circ\text{C}$	

TA78L20F

Electrical Characteristics

(Unless otherwise specified, $V_{IN} = 29\text{ V}$, $I_{OUT} = 40\text{ mA}$, $C_{IN} = 0.33\text{ }\mu\text{F}$, $C_{OUT} = 0.1\text{ }\mu\text{F}$, $0^\circ\text{C} \leq T_j \leq 125^\circ\text{C}$)

Characteristics	Symbol	Test Circuit	Test Condition	Min	Typ.	Max	Unit	
Output voltage	V_{OUT}	1	$T_j = 25^\circ\text{C}$	19.0	20	21.0	V	
Line regulation	Reg-line	1	$T_j = 25^\circ\text{C}$	$23.5\text{ V} \leq V_{IN} \leq 35\text{ V}$	—	33	330	mV
				$24\text{ V} \leq V_{IN} \leq 35\text{ V}$	—	28	285	
Load regulation	Reg-load	1	$T_j = 25^\circ\text{C}$	$1.0\text{ mA} \leq I_{OUT} \leq 100\text{ mA}$	—	33	180	mV
				$1.0\text{ mA} \leq I_{OUT} \leq 40\text{ mA}$	—	17	90	
Output voltage	V_{OUT}	1	$T_j = 25^\circ\text{C}$	$23.5\text{ V} \leq V_{IN} \leq 35\text{ V}$, $1.0\text{ mA} \leq I_{OUT} \leq 40\text{ mA}$	18.6	—	21.4	V
				$1.0\text{ mA} \leq I_{OUT} \leq 70\text{ mA}$	18.6	—	21.4	
Quiescent current	I_B	1	$T_j = 25^\circ\text{C}$	—	3.3	6.5	mA	
			$T_j = 125^\circ\text{C}$	—	—	6.0		
Quiescent current change	ΔI_B	1	$T_j = 25^\circ\text{C}$	$24\text{ V} \leq V_{IN} \leq 35\text{ V}$	—	—	1.5	mA
				$1.0\text{ mA} \leq I_{OUT} \leq 40\text{ mA}$	—	—	0.1	
Output noise voltage	V_{NO}	2	$T_a = 25^\circ\text{C}$, $10\text{ Hz} \leq f \leq 100\text{ kHz}$	—	170	—	μV_{rms}	
Long term stability	$\Delta V_{OUT}/\Delta t$	1	—	—	49	—	mV/kh	
Ripple rejection ratio	R.R.	3	$f = 120\text{ Hz}$, $25\text{ V} \leq V_{IN} \leq 35\text{ V}$, $T_j = 25^\circ\text{C}$	31	37	—	dB	
Dropout voltage	V_D	1	$T_j = 25^\circ\text{C}$, $I_{OUT} = 150\text{ mA}$	—	1.7	—	V	
Average temperature coefficient of output voltage	T_{CVO}	1	$I_{OUT} = 5\text{ mA}$	—	-1.7	—	$\text{mV}/^\circ\text{C}$	

TA78L24F

Electrical Characteristics

(Unless otherwise specified, $V_{IN} = 33\text{ V}$, $I_{OUT} = 40\text{ mA}$, $C_{IN} = 0.33\text{ }\mu\text{F}$, $C_{OUT} = 0.1\text{ }\mu\text{F}$, $0^\circ\text{C} \leq T_j \leq 125^\circ\text{C}$)

Characteristics	Symbol	Test Circuit	Test Condition	Min	Typ.	Max	Unit	
Output voltage	V_{OUT}	1	$T_j = 25^\circ\text{C}$	22.8	24	25.2	V	
Line regulation	Reg-line	1	$T_j = 25^\circ\text{C}$	$27.5\text{ V} \leq V_{IN} \leq 38\text{ V}$	—	35	350	mV
				$28\text{ V} \leq V_{IN} \leq 38\text{ V}$	—	30	300	
Load regulation	Reg-load	1	$T_j = 25^\circ\text{C}$	$1.0\text{ mA} \leq I_{OUT} \leq 100\text{ mA}$	—	40	200	mV
				$1.0\text{ mA} \leq I_{OUT} \leq 40\text{ mA}$	—	20	100	
Output voltage	V_{OUT}	1	$T_j = 25^\circ\text{C}$	$27.5\text{ V} \leq V_{IN} \leq 38\text{ V}$, $1.0\text{ mA} \leq I_{OUT} \leq 40\text{ mA}$	22.32	—	25.68	V
				$1.0\text{ mA} \leq I_{OUT} \leq 70\text{ mA}$	22.32	—	25.68	
Quiescent current	I_B	1	$T_j = 25^\circ\text{C}$	—	3.5	6.5	mA	
			$T_j = 125^\circ\text{C}$	—	—	6.0		
Quiescent current change	ΔI_B	1	$T_j = 25^\circ\text{C}$	$28\text{ V} \leq V_{IN} \leq 38\text{ V}$	—	—	1.5	mA
				$1.0\text{ mA} \leq I_{OUT} \leq 40\text{ mA}$	—	—	0.1	
Output noise voltage	V_{NO}	2	$T_a = 25^\circ\text{C}$, $10\text{ Hz} \leq f \leq 100\text{ kHz}$	—	200	—	μV_{rms}	
Long term stability	$\Delta V_{OUT}/\Delta t$	1	—	—	56	—	mV/kh	
Ripple rejection ratio	R.R.	3	$f = 120\text{ Hz}$, $29\text{ V} \leq V_{IN} \leq 39\text{ V}$, $T_j = 25^\circ\text{C}$	31	35	—	dB	
Dropout voltage	V_D	1	$T_j = 25^\circ\text{C}$, $I_{OUT} = 150\text{ mA}$	—	1.7	—	V	
Average temperature coefficient of output voltage	T_{CVO}	1	$I_{OUT} = 5\text{ mA}$	—	-2.0	—	$\text{mV}/^\circ\text{C}$	

Test Circuit 1/Standard Application

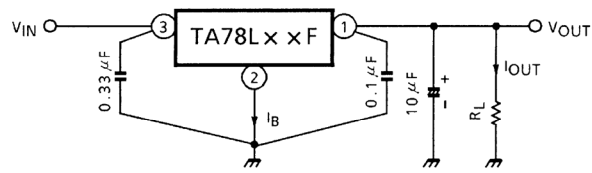

Test Circuit 2

V_{NO}

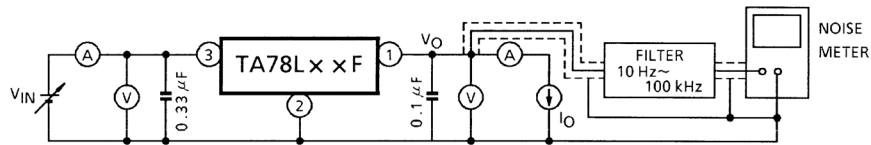

Test Circuit 3

$R.R.$

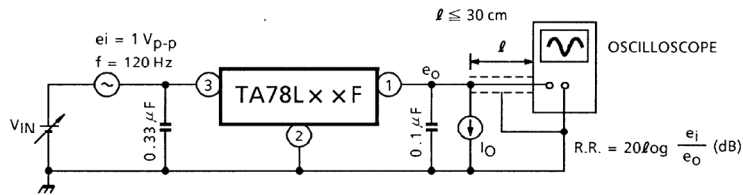

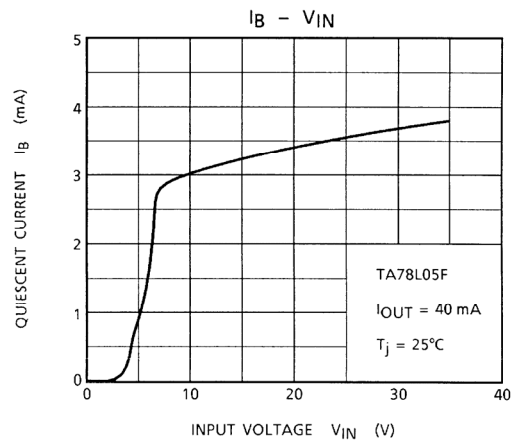
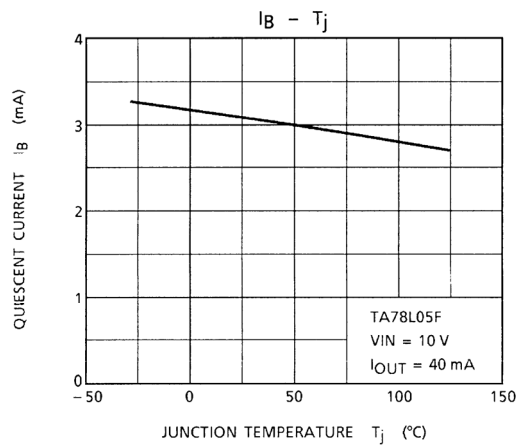
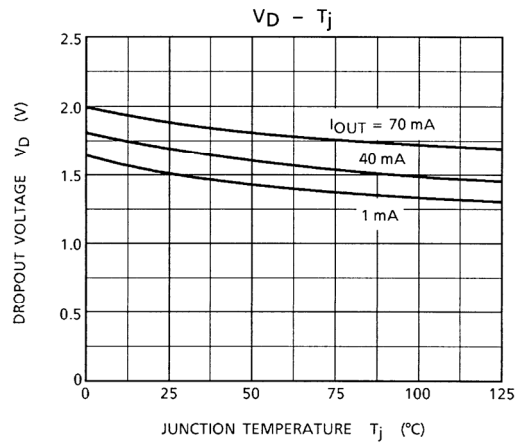
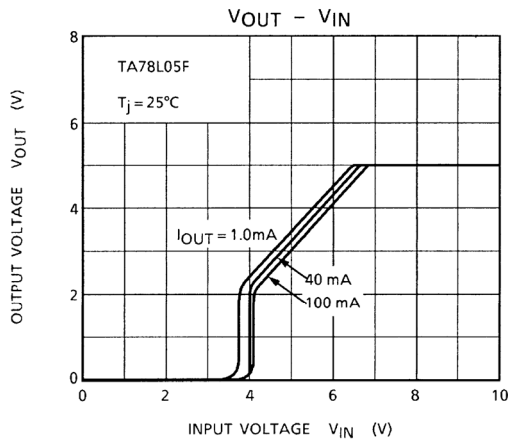
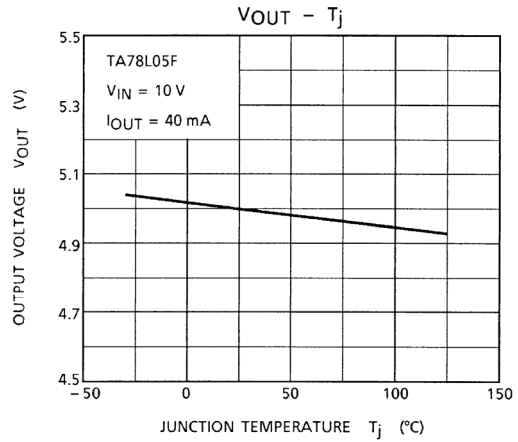
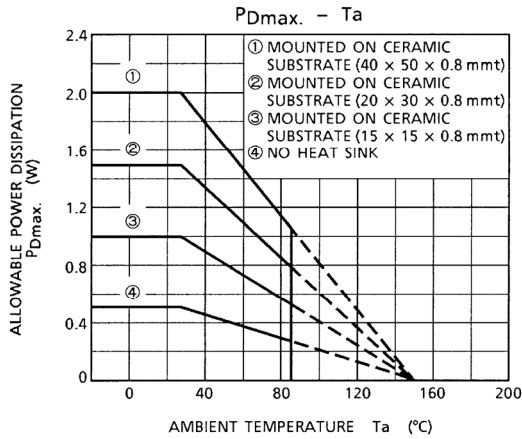

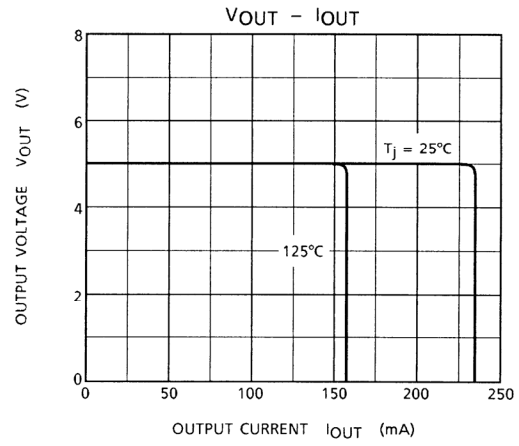
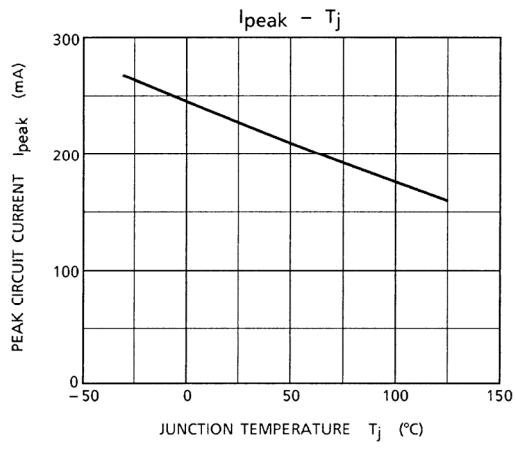

Precautions for Use

Destruction of the IC may occur if high voltage in excess of the IC output voltage (typ. value) is applied to the IC output terminal. Where this possibility exists, connect a Zener diode between the output terminal and GND to prevent any application of excessive voltage. In particular, in a current boosting circuit such as that shown in Application Circuit Example (2), if the input voltage is suddenly applied by stages and, furthermore, load is light, excessive voltage may be applied transiently to the output terminal of the IC. In such a case, it may become necessary to increase the capacity of the output capacitor as appropriate, use a smaller R₁ (a resistor for bypassing IC bias current) or gradually raise the input voltage, in addition to using a Zener diode as mentioned above.

Application Circuits

(1) Standard Application

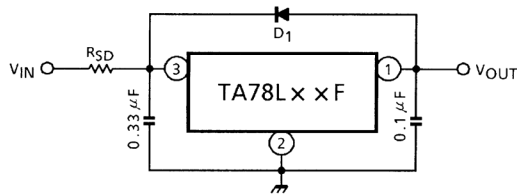

D₁ : IC protective diode
 When surge voltage is applied to IC output terminal or V_{IN} < V_{OUT} at the time of power ON/OFF, always connect the high speed switching diode D₁.
 R_{SD} : Power limiting resistor
 If V_{IN} is too high, always connect R_{SD} in order to reduce power consumption of IC.

(2) A. Current Boost Voltage Regulator

B. Short-Circuit Protection

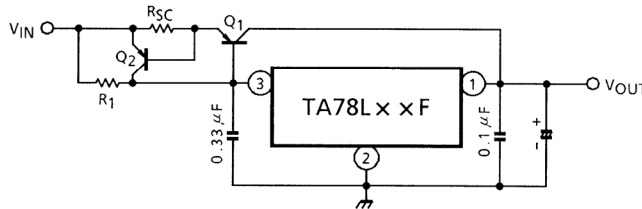

$$R_{SC} = \frac{V_{BE2}}{I_{SC}}$$

where, I_{SC} : Short-Circuit current

(3) Current Regulator

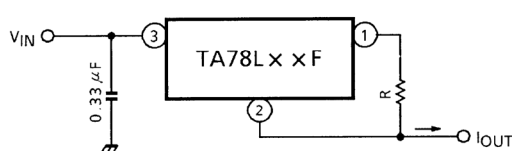

$$I_{OUT} = \frac{V_{OUT}}{R} + I_B$$

(4) Voltage Boost Regulator

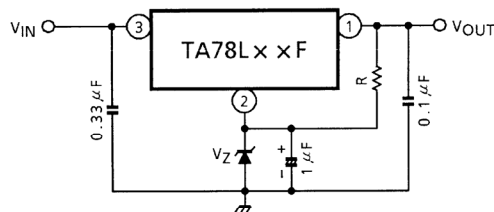

V_{OUT} = V_Z + V_{OUT} (of IC)
 Apply current of several mA to R.

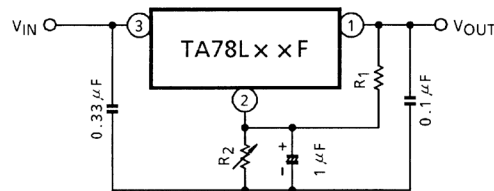

$$V_{OUT} = R_2 (I_B + \frac{V_{OUT} \text{ (of IC)}}{R_1}) + V_{OUT} \text{ (of IC)}$$

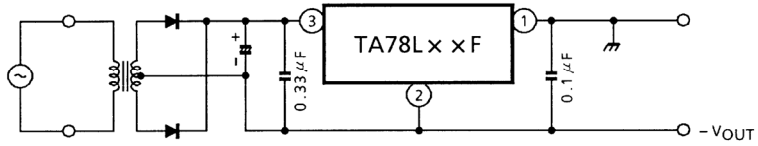
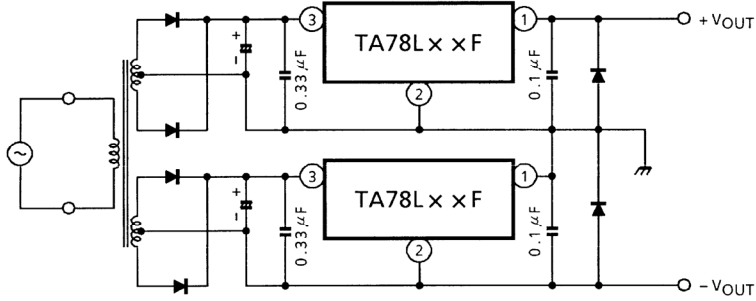
(5) Negative Regulator**(6) Positive and Negative Regulator**

Package Dimensions

HSOP3-P-1.50

Unit : mm

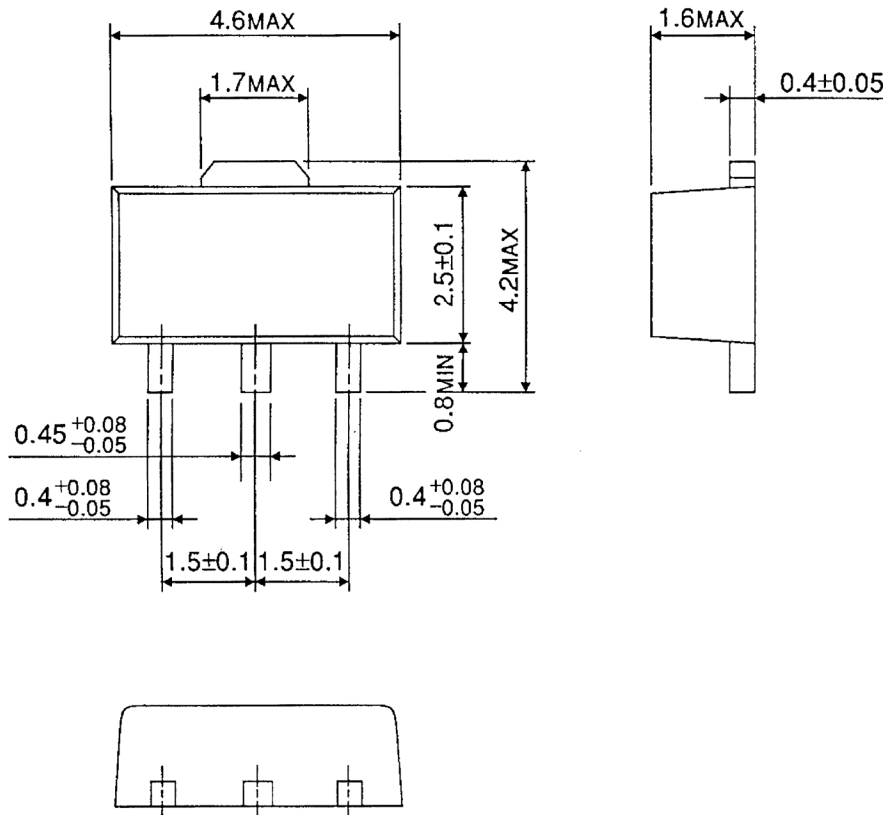

Weight : 0.05 g (Typ.)

RESTRICTIONS ON PRODUCT USE

030619EBA

- The information contained herein is subject to change without notice.
- The information contained herein is presented only as a guide for the applications of our products. No responsibility is assumed by TOSHIBA for any infringements of patents or other rights of the third parties which may result from its use. No license is granted by implication or otherwise under any patent or patent rights of TOSHIBA or others.
- TOSHIBA is continually working to improve the quality and reliability of its products. Nevertheless, semiconductor devices in general can malfunction or fail due to their inherent electrical sensitivity and vulnerability to physical stress. It is the responsibility of the buyer, when utilizing TOSHIBA products, to comply with the standards of safety in making a safe design for the entire system, and to avoid situations in which a malfunction or failure of such TOSHIBA products could cause loss of human life, bodily injury or damage to property.
In developing your designs, please ensure that TOSHIBA products are used within specified operating ranges as set forth in the most recent TOSHIBA products specifications. Also, please keep in mind the precautions and conditions set forth in the "Handling Guide for Semiconductor Devices," or "TOSHIBA Semiconductor Reliability Handbook" etc..
- The TOSHIBA products listed in this document are intended for usage in general electronics applications (computer, personal equipment, office equipment, measuring equipment, industrial robotics, domestic appliances, etc.). These TOSHIBA products are neither intended nor warranted for usage in equipment that requires extraordinarily high quality and/or reliability or a malfunction or failure of which may cause loss of human life or bodily injury ("Unintended Usage"). Unintended Usage include atomic energy control instruments, airplane or spaceship instruments, transportation instruments, traffic signal instruments, combustion control instruments, medical instruments, all types of safety devices, etc.. Unintended Usage of TOSHIBA products listed in this document shall be made at the customer's own risk.
- The products described in this document are subject to the foreign exchange and foreign trade laws.
- TOSHIBA products should not be embedded to the downstream products which are prohibited to be produced and sold, under any law and regulations.