



LEDTECH ELECTRONICS CORP.

NANYA ROAD, MUGANG ZHAOQING
CITY GUANGDONG CHINA.

TEL: 86-758-2875541, 2870651, 2877464, 2876185, 2877017

FAX: 86-758-2878014

[Http://www.ledtech.com.tw](http://www.ledtech.com.tw)

SPECIFICATION

PART NO. : LT5K83-1Y-940-SA8

3.2 x 2.8mm SMD TYPE



Approved by	Checked by	Prepared by
<i>Tung</i>	<i>Lian</i>	<i>Karen</i>

Package Dimensions

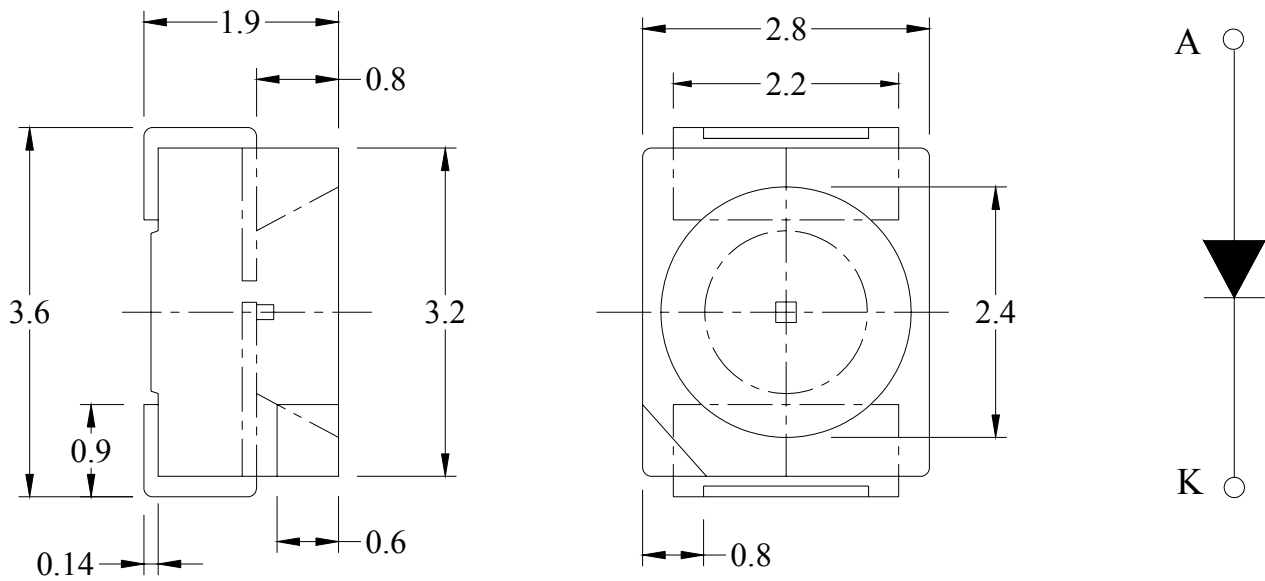

Notes:

1. All dimensions are in mm.
2. Tolerance is ± 0.25 mm unless otherwise noted.

Description

Part No.	LED Chip		Lens Color
	Material	Emitting Color	
LT5K83-1Y-940-SA8	AlGaAs/GaAs	Infrared	Water Clear



LT5K83-1Y-940-SA8

3.2 x 2.8mm SMD TYPE

Absolute Maximum Ratings at Ta=25°C

Parameter	Symbol	Rating	Unit
Power Dissipation	P _D	75	mW
Reverse Voltage	V _R	5	V
D.C. Forward Current	I _f	50	mA
Peak Current(1/10Duty Cycle,0.1ms Pulse Width.)	I _f (Peak)	200	mA
Operating Temperature Range	T _{opr.}	-40 to +100	°C
Storage Temperature Range	T _{stg.}	-40 to +100	°C
Soldering Temperature	T _{sl.}	Reflow Soldering: 260°C for 10 sec. Hand Soldering: 350°C for 3 sec.	

Electrical and Optical Characteristics:

Parameter	Symbol	Condition	Min.	Typ.	Max.	Unit
Radiant Output Power	P _o	I _f =20mA	4.8	8.0		mw
Forward Voltage	V _f	I _f =20mA		1.22	1.5	V
Peak Wavelength	λ _p	I _f =20mA		940		nm
Dominant Wavelength	λ _d	I _f =20mA		---		nm
Reverse Current	I _r	V _r =5V			100	μA
Viewing Angle	2θ 1/2	I _f =20mA		120		deg
Spectrum Line Halfwidth	Δλ	I _f =20mA		50		nm

Note: Customer's special requirements are also welcome

Typical Electrical/Optical Characteristic Curves

(25°C Ambient Temperature Unless Otherwise Noted)

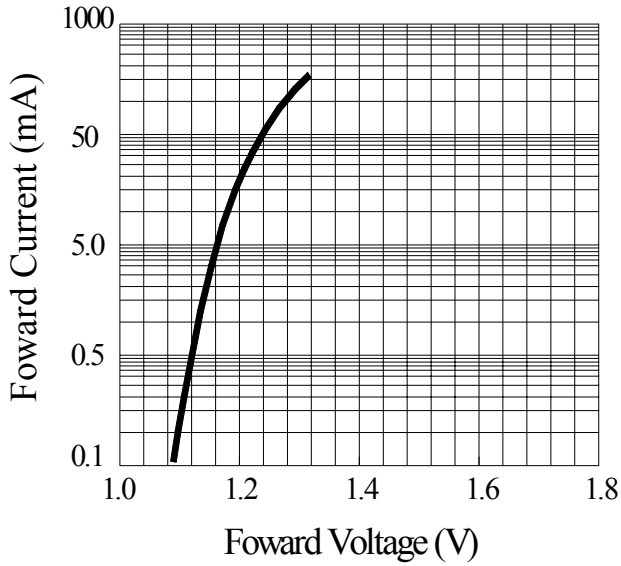

Forward Current VS. Applied Voltage

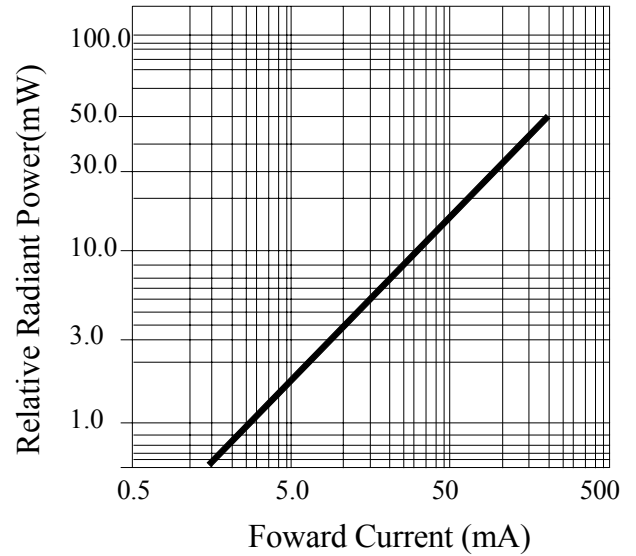

Forward Current VS. Luminous Intensity

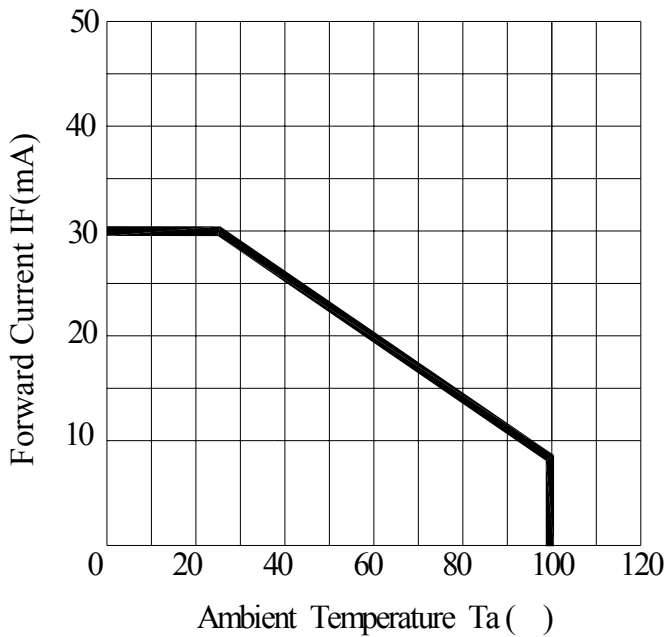

Ambient Temperature VS. Forward Current

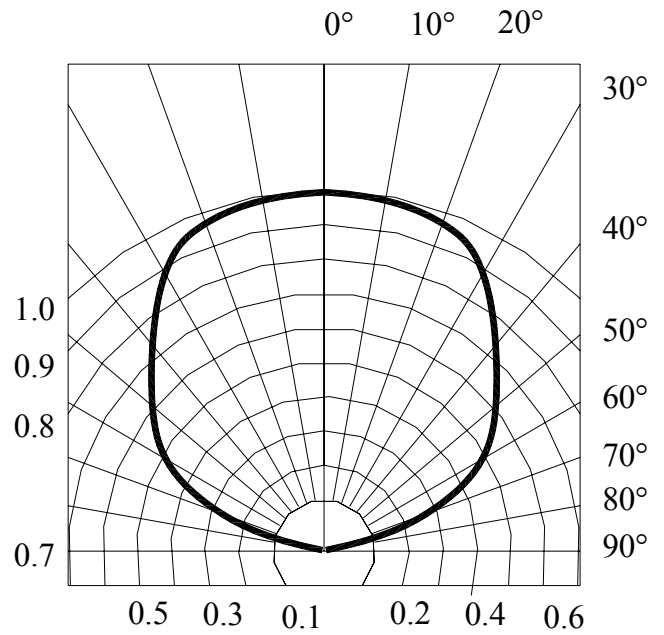

Radiation Diagram

PRECAUTION IN USE

Storage

Recommended storage environment

Temperature: 5°C ~ 30°C (41°F ~ 86°F)

Humidity: 60% RH Max.

Use within 7 days after opening of sealed vapor/ESD barrier bags.

If unused LEDs remain, they should be stored in moisture proof packages, such as sealed container with packages of moisture absorbent material (silica gel). It is also recommended to return the LEDs to the original moisture proof bag and to reseal the moisture proof bag again.

Fold the opened bag firmly and keep in dry environment.

Soldering

	Reflow Soldering		Hand Soldering	
	Lead Solder	Lead - free Solder		
Pre-heat	120~150°C	180~200°C	Temperature	350°C Max.
Pre-heat time	120sec. Max.	120sec. Max.	Soldering time	3sec. Max. (one time only)
Peak temperature	240°C Max.	260°C Max.		
Soldering time	10sec. Max.	10sec. Max.		
Condition	refer to Temperature- profile 1	refer to Temperature- profile 2		

*After reflow soldering rapid cooling should be avoided.

[Temperature-profile (Surface of circuit board)]

Use the conditions shown to the under figure.

< 1 : Lead Solder >

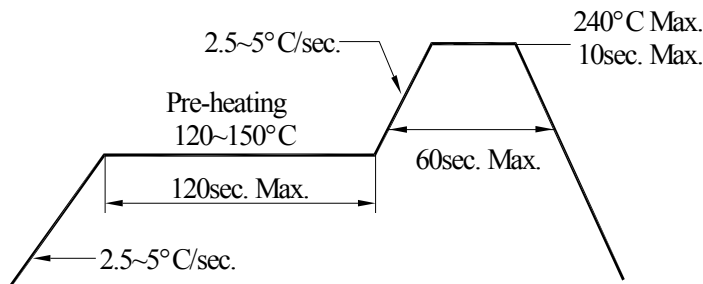

< 2 : Lead-free Solder >

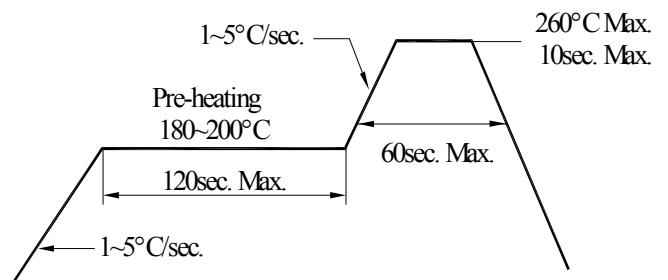

[Recommended soldering pad design]

Use the following conditions shown in the figure.

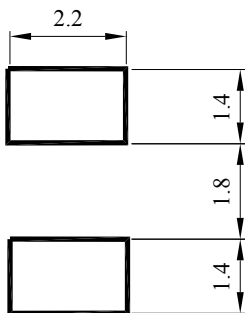

(UNIT:mm)

Handling of Silicone Resin LEDs

Handling Indications

During processing, mechanical stress on the surface should be minimized as much as possible. Sharp objects of all types should not be used to pierce the sealing compound

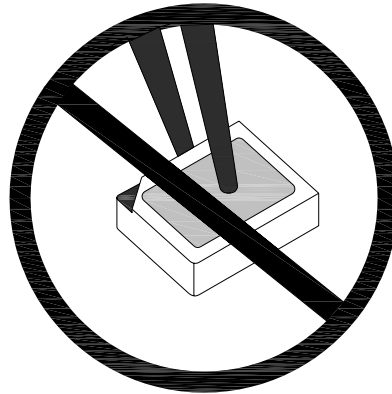

Figure 1

In general, LEDs should only be handled from the side. By the way, this also applies to LEDs without a silicone sealant, since the surface can also become scratched.

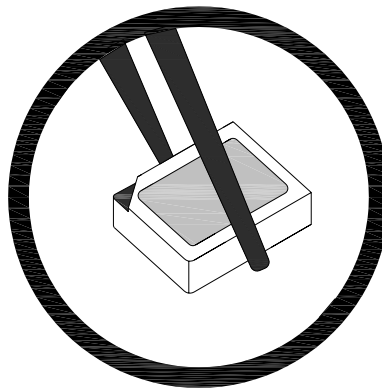
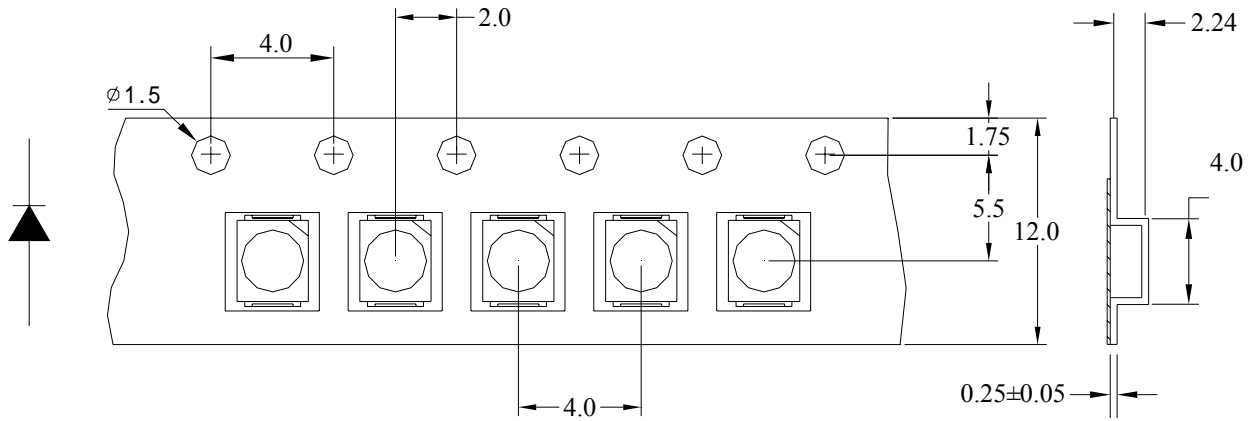

Figure 2

When populating boards in SMT production, there are basically no restrictions regarding the form of the pick and place nozzle, except that mechanical pressure on the surface of the resin must be prevented.

This is assured by choosing a pick and place nozzle which is larger than the LED's reflector area.

Dimensions for Tape



Dimensions for Reel

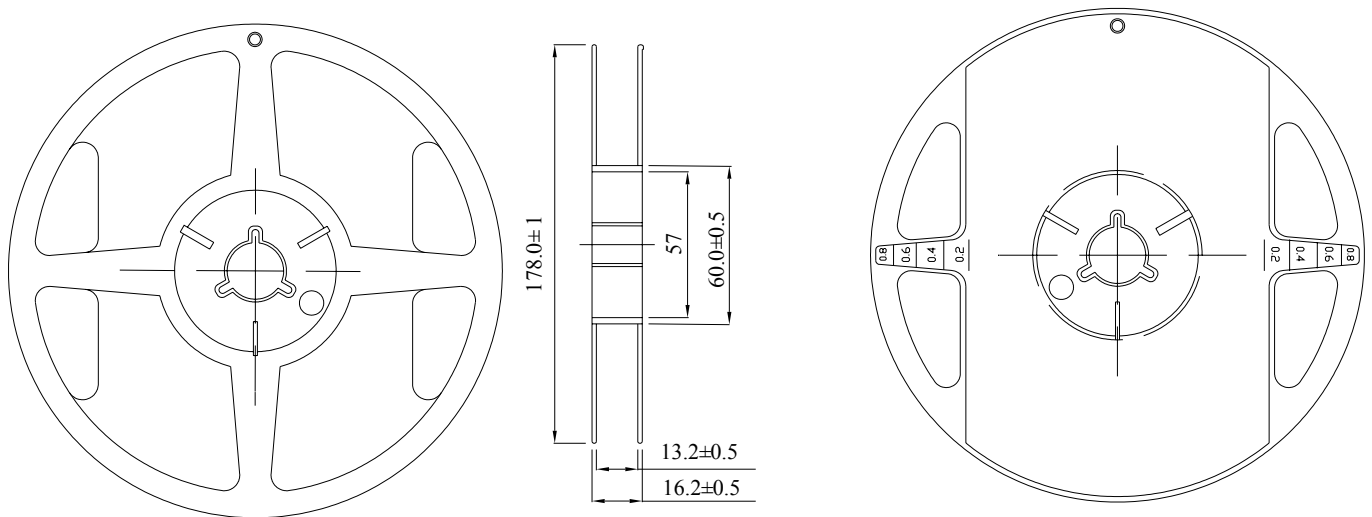

Notes:

1. All dimensions are in mm, tolerance is ± 2.0 mm unless otherwise noted.
2. Specifications are subject to change without notice.

Packing

REEL
QUANTITY: 2,000 PCS

LEDTECH ELECTRONICS CORP.
PART NO :LTXXXX-XX
Q'TY : PCS
LOT NO :XXXXXXXXXX
DATE :
BIN CODE:

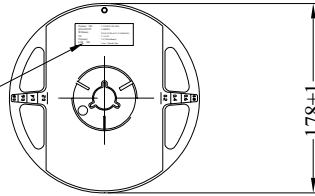

BAG
QUANTITY: 2,000 PCS

LEDTECH ELECTRONICS CORP.
PART NO :LTXXXX-XX
Q'TY : PCS
LOT NO :XXXXXXXXXX
DATE :
BIN CODE:

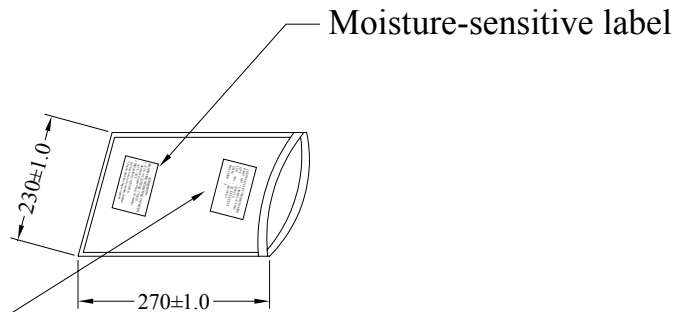

INSIDE BOX
QUANTITY: 4 BAGS
TOTAL: 8,000 PCS

LEDTECH ELECTRONICS CORP.
PART NO :LTXXXX-XX
Q'TY : PCS
LOT NO :XXXXXXXXXX
DATE :
BIN CODE:

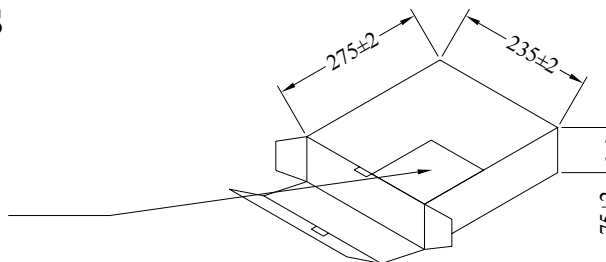

Notes:

- 1.All dimensions are in mm, tolerance is ± 2.0 mm unless otherwise noted.
- 2.Specifications are subject to change without notice.