



Preview of Crystal SMD (2.5 x 2.0) 4 Pads

Part #: 24MEZDHGZMA-SM25204

1. GENERAL

- 1.1 Center Frequency: 24.000 MHz
- 1.2 Holder Type: Crystal SMD (2.5x2.0) 4 pads
- 1.3 Mode of Oscillation: Fundamental
- 1.4 Load Capacitance: 10 +/-0.2pF
- 1.5 Operating Temperature: -40°C to +80°C
- 1.6 Storage Temperature: -55°C to +125°C
- 1.7 Drive Level: 100μW max

2. DIMENSION (mm):

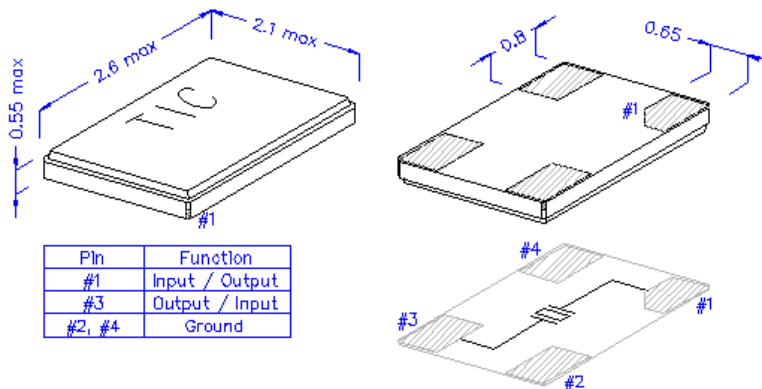

3. ELECTRICAL CHARACTERISTICS

This test shall be performed under the conditions of temperature at 25 +/-3°C .

- 2.1 Frequency Tolerance: +/-20ppm
- 2.2 Frequency Stability: +/-30ppm
- 2.3 Series Resistance: 60Ω max
- 2.4 Shunt Capacitance: 7.0 pF max
- 2.5 Insulation Resistance: 500meg. Ω min / DC 100V +/-15V D.C.
- 2.6 Aging: +/-5ppm / year
- 2.7 Measuring Instrument: 250B PI-Network