



LEDTECH ELECTRONICS CORP.

NANYA ROAD, MUGANG ZHAOQING
CITY GUANGDONG CHINA.

TEL: 86-758-2875541, 2870651, 2877464, 2876185, 2877017

FAX: 86-758-2878014

[Http://www.ledtech.com.tw](http://www.ledtech.com.tw)

SPECIFICATION

PART NO. : LT5KA3-AA-UGC1-T01

3.2 x 2.8mm SMD TYPE



Approved by

Checked by

Prepared by

Tung

Lian

Show

Package Dimensions

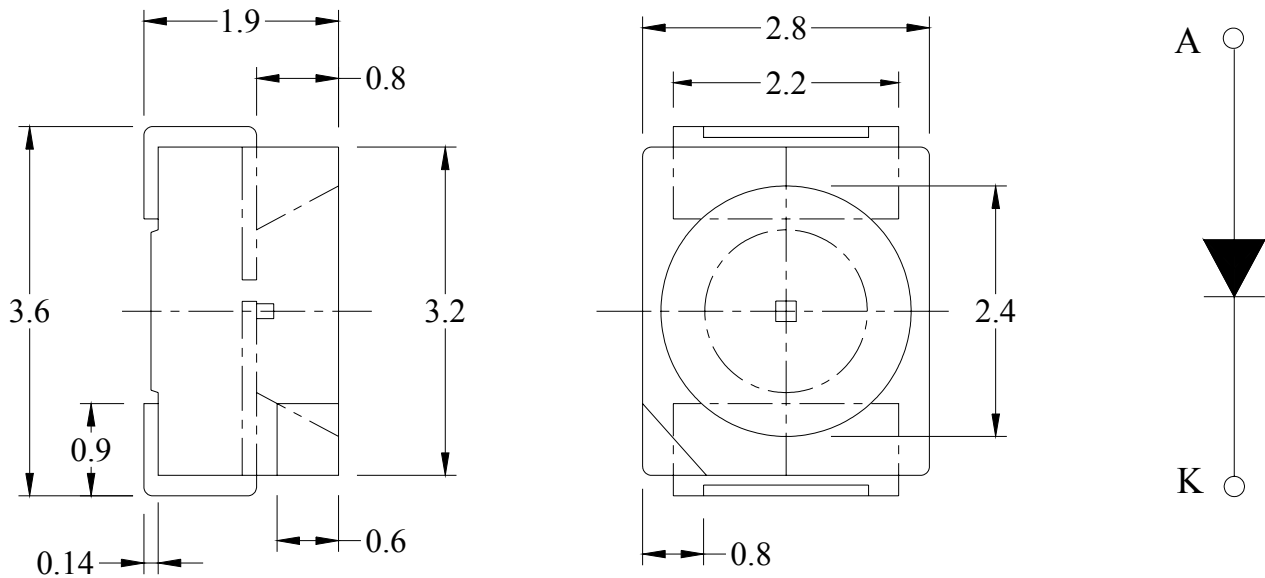

Notes:

1. All dimensions are in mm.
2. Tolerance is ± 0.25 mm unless otherwise noted.

Description

Part No.	LED Chip		Lens Color
	Material	Emitting Color	
LT5KA3-AA-UGC1-T01	AlGaInP/GaAs	Amber	Water Clear

Absolute Maximum Ratings at Ta=25°C

Parameter	Symbol	Rating	Unit
Power Dissipation	P _D	72	mW
Reverse Voltage	V _R	5	V
D.C. Forward Current	I _f	30	mA
Peak Current(1/10Duty Cycle,0.1ms Pulse Width.)	I _f (Peak)	100	mA
Operating Temperature Range	T _{opr.}	-25 to +85	°C
Storage Temperature Range	T _{stg.}	-40 to +100	°C
Soldering Temperature	T _{sld.}	Reflow Soldering: 260°C for 10 sec. Hand Soldering: 350°C for 3 sec.	

Electrical and Optical Characteristics:

Parameter	Symbol	Condition	Min.	Typ.	Max.	Unit
Luminous Intensity	I _v	I _f =20mA	135	250		mcd
Forward Voltage	V _f	I _f =20mA		1.9	2.4	V
Peak Wavelength	λ _p	I _f =20mA		610		nm
Dominant Wavelength	λ _d	I _f =20mA		605		nm
Reverse Current	I _r	V _r =5V			100	μA
Viewing Angle	2θ 1/2	I _f =20mA		120		deg
Spectrum Line Halfwidth	Δλ	I _f =20mA		17		nm

Notes: 1.The datas tested by IS tester.

2. Customer's special requirements are also welcome

Typical Electrical/Optical Characteristic Curves

(25°C Ambient Temperature Unless Otherwise Noted)

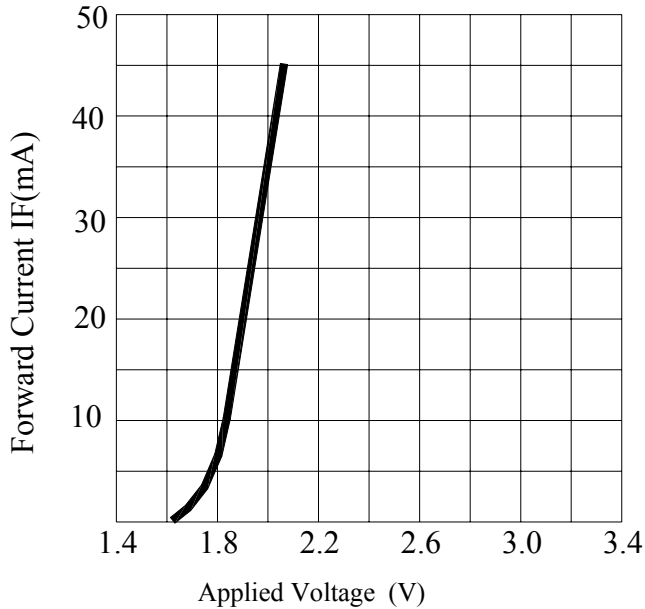

Forward Current VS. Applied Voltage

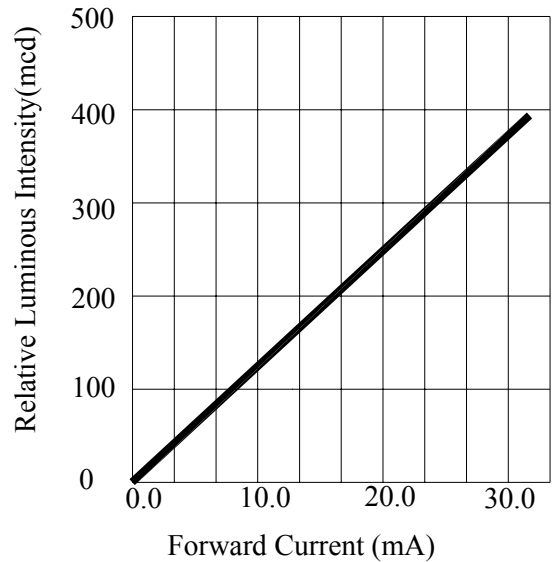

Forward Current VS. Luminous Intensity

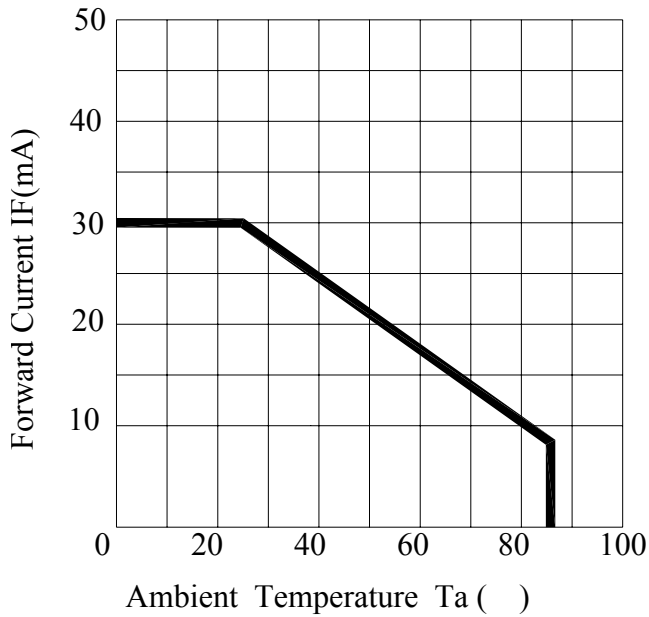

Ambient Temperature VS. Forward Current

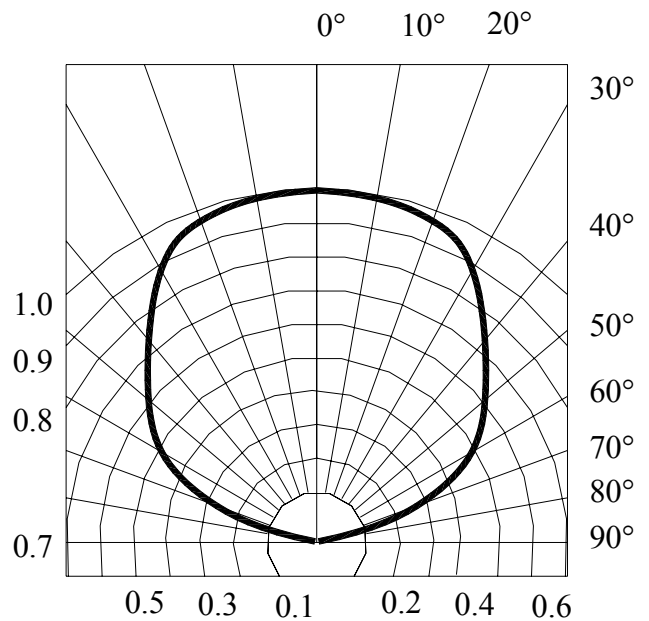

Radiation Diagram

PRECAUTION IN USE

Storage

Recommended storage environment

Temperature: 5°C ~ 30°C (41°F ~ 86°F)

Humidity: 60% RH Max.

Use within 7 days after opening of sealed vapor/ESD barrier bags.

If the moisture absorbent material (silica gel) has faded away or the LEDs have exceeded the storage time, baking treatment should be performed using the following conditions.

Baking treatment : 60±5°C for 24 hours.

Fold the opened bag firmly and keep in dry environment.

Soldering

	Reflow Soldering		Hand Soldering	
	Lead Solder	Lead – free Solder		
Pre-heat	120~150°C	180~200°C	Temperature	350°C Max.
Pre-heat time	120sec. Max.	120sec. Max.	Soldering time	3sec. Max. (one time only)
Peak temperature	240°C Max.	260°C Max.		
Soldering time	10sec. Max.	10sec. Max.		
Condition	refer to Temperature- profile 1	refer to Temperature- profile 2		

*After reflow soldering rapid cooling should be avoided.

[Temperature-profile (Surface of circuit board)]

Use the conditions shown to the under figure.

< 1 : Lead Solder >

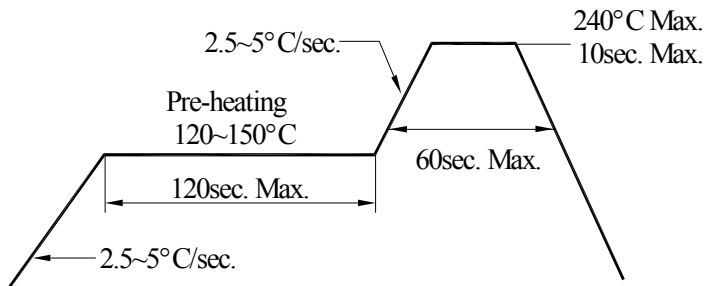

< 2 : Lead-free Solder >

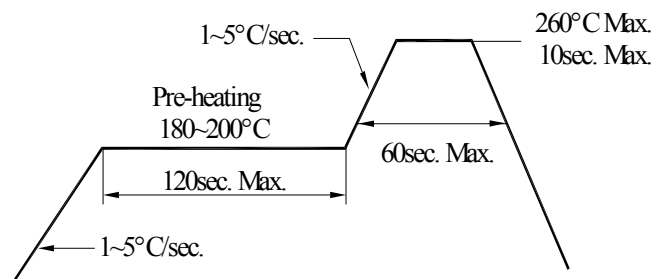

[Recommended soldering pad design]

Use the following conditions shown in the figure.

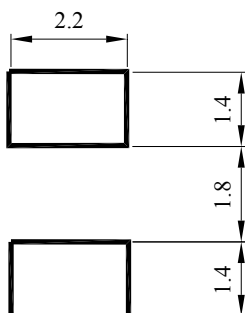

(UNIT:mm)

Dimensions for Tape

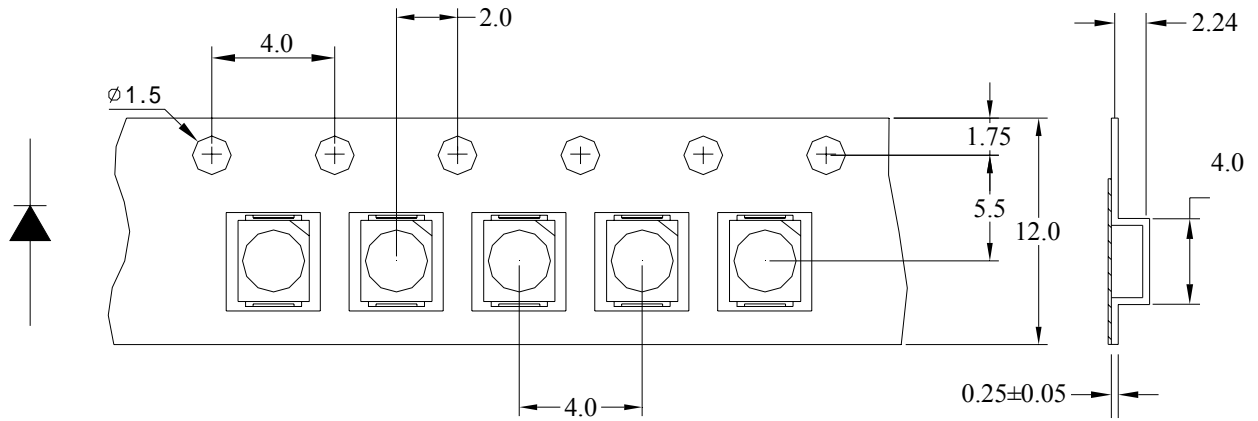

Dimensions for Reel

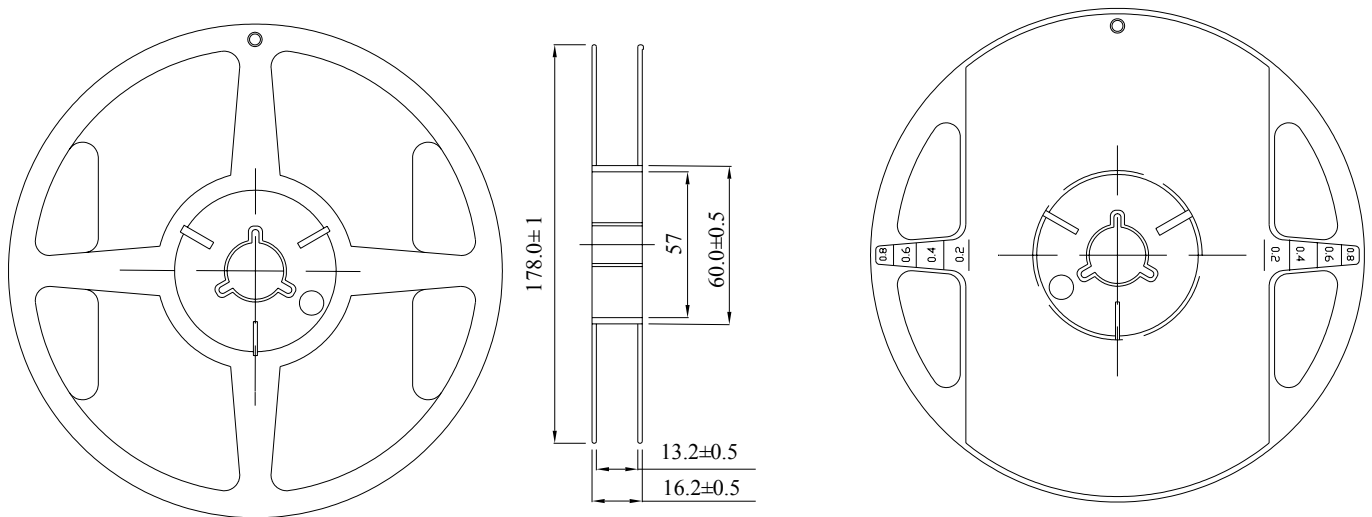

Notes:

1. All dimensions are in mm, tolerance is ± 2.0 mm unless otherwise noted.
2. Specifications are subject to change without notice.

Packing

REEL
QUANTITY: 2,000 PCS

LEDTECH ELECTRONICS CORP.
PART NO :LTXXXX-XX
Q'TY : PCS
LOT NO :XXXXXXXXXX
DATE :
BIN CODE:

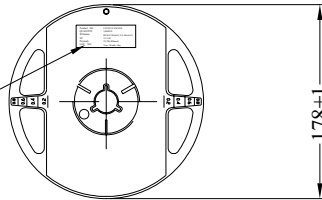

BAG
QUANTITY: 2,000 PCS

LEDTECH ELECTRONICS CORP.
PART NO :LTXXXX-XX
Q'TY : PCS
LOT NO :XXXXXXXXXX
DATE :
BIN CODE:

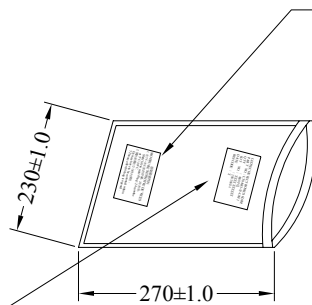

溼氣敏感材料
MOISTURE SENSITIVE DEVICES
1. 在5°C-30°C密封貯藏，1年有效。
Shelf life in sealed bag : 12 months
at 5°C-30°C .
2. 開封後需在168小時內使用。
Devices have to be mounted within
168 hours after this bag is opened .

INSIDE BOX
QUANTITY: 4 BAGS
TOTAL: 8,000 PCS

LEDTECH ELECTRONICS CORP.
PART NO :LTXXXX-XX
Q'TY : PCS
LOT NO :XXXXXXXXXX
DATE :
BIN CODE:

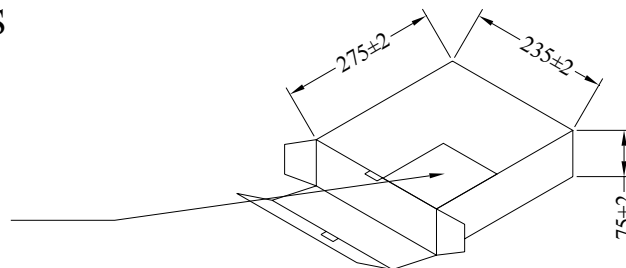

Notes:

- 1.All dimensions are in mm, tolerance is ± 2.0 mm unless otherwise noted.
- 2.Specifications are subject to change without notice.