



# 1.5°C Accurate Digital Temperature Sensor with SPI™ Interface

## FEATURES

- **DIGITAL OUTPUT: SPI-Compatible Interface**
- **RESOLUTION: 12-Bit + Sign, 0.0625°C**
- **ACCURACY:**  
±1.5°C from –25°C to +85°C (max)
- **LOW QUIESCENT CURRENT: 50µA (max)**
- **WIDE SUPPLY RANGE: 2.7V to 5.5V**
- **TINY SOT23-6 PACKAGE**
- **OPERATION TO 150°C**

## APPLICATIONS

- **POWER-SUPPLY TEMPERATURE MONITORING**
- **COMPUTER PERIPHERAL THERMAL PROTECTION**
- **NOTEBOOK COMPUTERS**
- **CELL PHONES**
- **BATTERY MANAGEMENT**
- **OFFICE MACHINES**

## DESCRIPTION

The TMP121 and TMP123 are SPI-compatible temperature sensors available in the tiny SOT23-6 package. Requiring no external components, the TMP121 and TMP123 are capable of measuring temperatures within 2°C of accuracy over a temperature range of –40°C to +125°C. Low supply current, and a supply range from 2.7V to 5.5V, make the TMP121 and TMP123 excellent candidates for low-power applications.

The TMP121 and TMP123 are ideal for extended thermal measurement in a variety of communication, computer, consumer, environmental, industrial, and instrumentation applications.

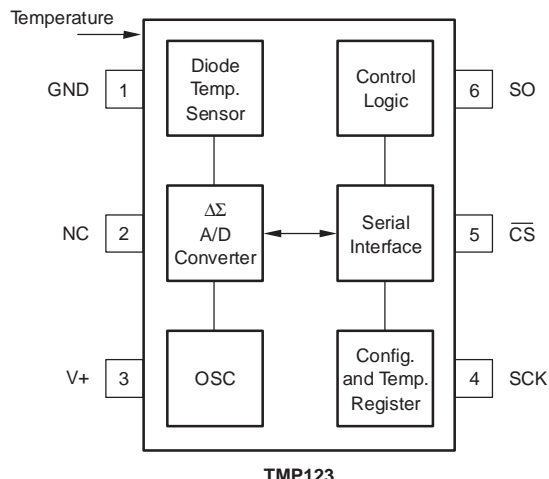
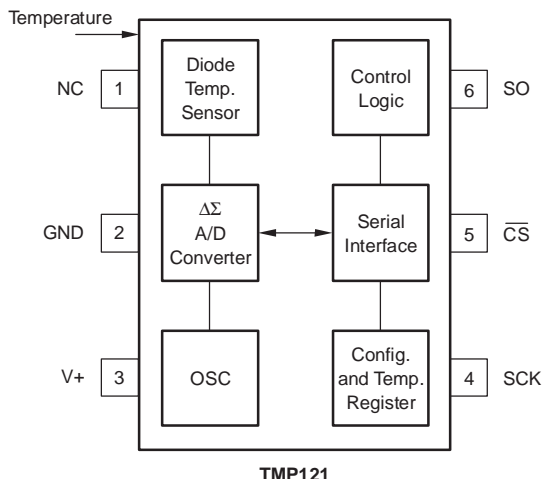

NC = No Connection<sup>(1)</sup>

NC = No Connection<sup>(1)</sup>

(1) Pins labeled NC should be left floating or connected to GND.



Please be aware that an important notice concerning availability, standard warranty, and use in critical applications of Texas Instruments semiconductor products and disclaimers thereto appears at the end of this data sheet.

All trademarks are the property of their respective owners.

### ABSOLUTE MAXIMUM RATINGS(1)

Power Supply, V+ . . . . .	7V
Input Voltage(2) . . . . .	–0.3V to +7V
Input Current . . . . .	10mA
Operating Temperature Range . . . . .	–55°C to +150°C
Storage Temperature Range . . . . .	–60°C to +150°C
Junction Temperature (T <sub>J</sub> max) . . . . .	+150°C
Lead Temperature (soldering) . . . . .	+300°C

- (1) Stresses above these ratings may cause permanent damage. Exposure to absolute maximum conditions for extended periods may degrade device reliability. These are stress ratings only, and functional operation of the device at these or any other conditions beyond those specified is not supported.
- (2) Input voltage rating applies to all TMP121 and TMP123 input voltages.



This integrated circuit can be damaged by ESD. Texas Instruments recommends that all integrated circuits be handled with appropriate precautions. Failure to observe proper handling and installation procedures can cause damage.

ESD damage can range from subtle performance degradation to complete device failure. Precision integrated circuits may be more susceptible to damage because very small parametric changes could cause the device not to meet its published specifications.

### ORDERING INFORMATION(1)

PRODUCT	PACKAGE-LEAD	PACKAGE DESIGNATOR	PACKAGE MARKING
TMP121	SOT23-6	DBV	T121
TMP123			T123

- (1) For the most current package and ordering information, see the Package Option Addendum at the end of this document, or see the TI web site at [www.ti.com](http://www.ti.com).

### PIN CONFIGURATIONS

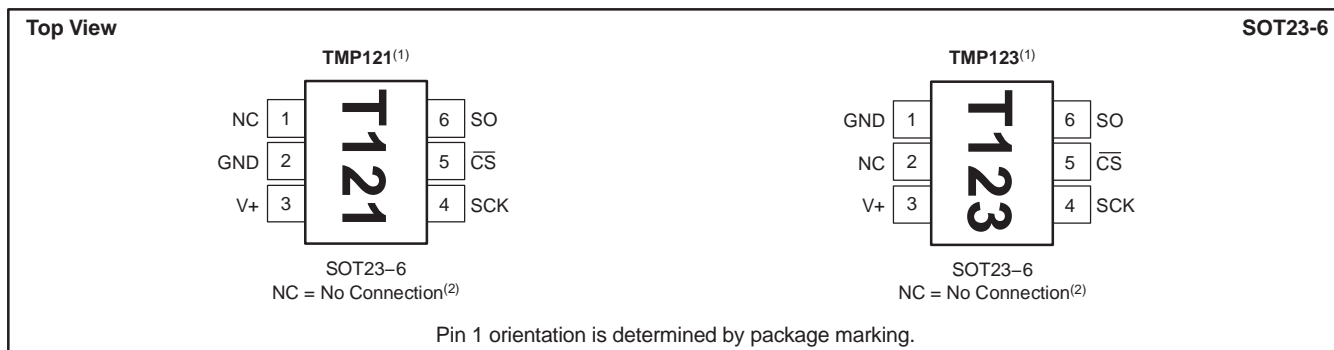

- (1) Pin 1 of the SOT23-6 package is determined by orienting the package marking as shown.
- (2) Pins labeled NC should be left floating or connected to GND.

## ELECTRICAL CHARACTERISTICS

 At  $T_A = -40^\circ\text{C}$  to  $+125^\circ\text{C}$  and  $V_+ = 2.7\text{V}$  to  $5.5\text{V}$ , unless otherwise noted.

PARAMETER	CONDITIONS	TMP121, TMP123			UNIT
		MIN	TYP	MAX	
<b>TEMPERATURE INPUT</b>					
Range		-40		+125	$^\circ\text{C}$
Accuracy (temperature error)	$-25^\circ\text{C}$ to $+85^\circ\text{C}$		$\pm 0.5$	$\pm 1.5$	$^\circ\text{C}$
	$-40^\circ\text{C}$ to $+125^\circ\text{C}$		$\pm 1.0$	$\pm 2.0$	$^\circ\text{C}$
	$-40^\circ\text{C}$ to $+150^\circ\text{C}$		$\pm 1.5$		$^\circ\text{C}$
vs Supply		-0.3	0.1	+0.3	$^\circ\text{C}/\text{V}$
Resolution			$\pm 0.0625$		$^\circ\text{C}$
<b>DIGITAL INPUT/OUTPUT</b>					
Input Logic Levels:					
$V_{IH}$		0.7(V+)			V
$V_{IL}$				0.3(V+)	V
Input Current, SO, SCK, $\overline{\text{CS}}$	$I_{IN}$ $0\text{V} \leq V_{IN} \leq V_+$			$\pm 1$	$\mu\text{A}$
Output Logic Levels:					
$V_{OL\ SO}$	$I_{SINK} = 3\text{mA}$			0.4	V
$V_{OH\ SO}$	$I_{SOURCE} = 2\text{mA}$	(V+)-0.4			V
Resolution			12		Bits
Input Capacitance, SO, SCK, $\overline{\text{CS}}$			2.5		pF
Conversion Time	12-Bit		240	320	ms
Conversion Period <sup>(1)</sup>	12-Bit		480	640	ms
<b>POWER SUPPLY</b>					
Operating Range		2.7		5.5	V
Quiescent Current	$I_Q$ Serial Bus Inactive		35	50	$\mu\text{A}$
Shutdown Current (TMP121)	$I_{SD}$ Serial Bus Inactive		0.1	1	$\mu\text{A}$
Shutdown Current (TMP123)	$I_{SD}$ Serial Bus Inactive		0.1	3	$\mu\text{A}$
<b>TEMPERATURE RANGE</b>					
Specified Range		-40		+125	$^\circ\text{C}$
Operating Range		-55		+150	$^\circ\text{C}$
Storage Range		-60		+150	$^\circ\text{C}$
Thermal Resistance	$\theta_{JA}$ SOT23-6 Surface-Mount		200		$^\circ\text{C}/\text{W}$

(1) Period indicates time between conversion starts.

**TYPICAL CHARACTERISTICS**

At  $T_A = +25^\circ\text{C}$  and  $V_+ = 5.0\text{V}$ , unless otherwise noted.

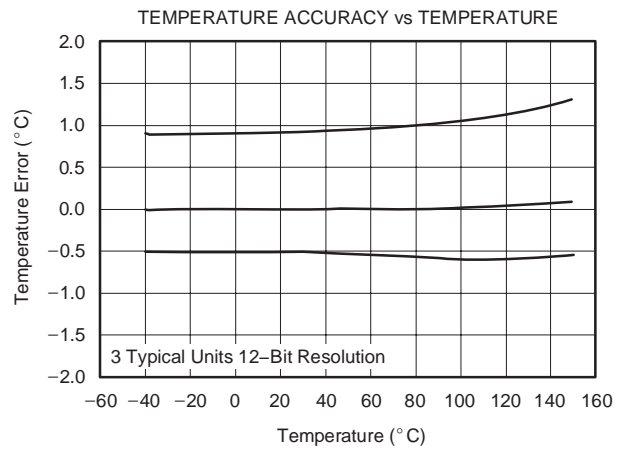
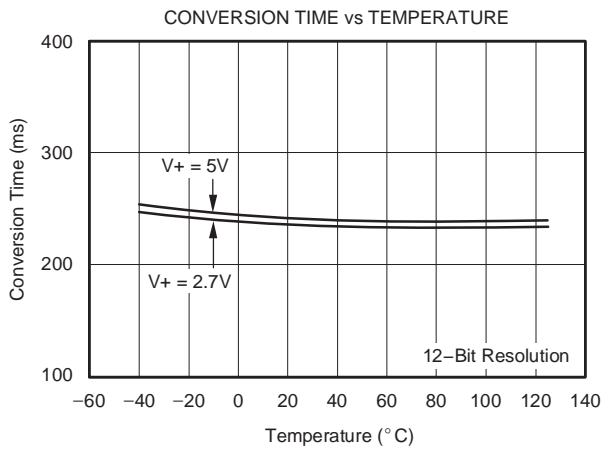
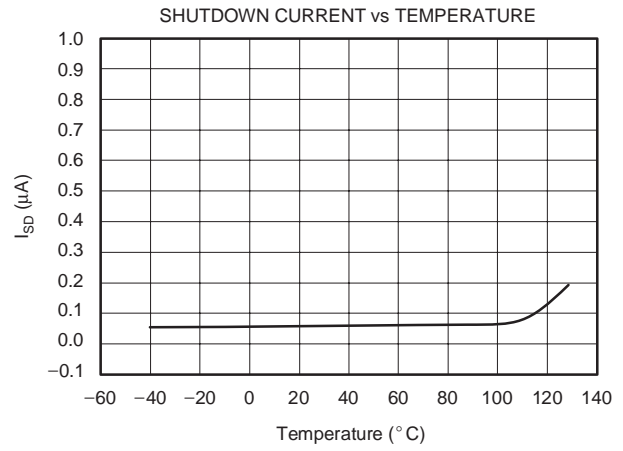
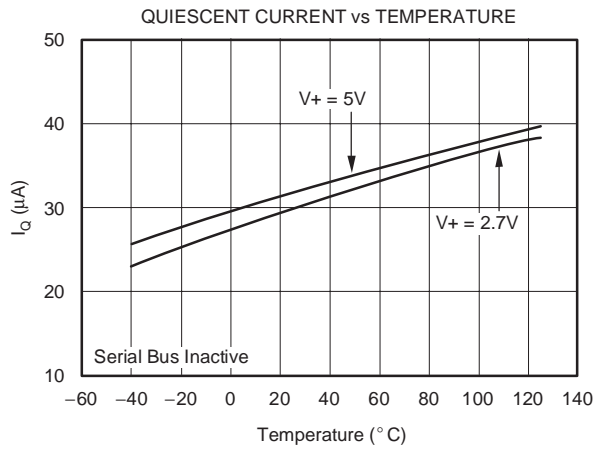

## APPLICATIONS INFORMATION

The TMP121 and TMP123 are 12-bit plus sign read-only digital temperature sensors optimal for thermal management and thermal protection applications. The TMP121 and the TMP123 communicate through a serial interface that is SPI-compatible. Temperature is converted to a 12-bit plus sign data word with 0.0625°C resolution. The TMP121 and TMP123 are specified for a temperature range of -40°C to +125°C, with operation extending from -55°C to +150°C.

The TMP121 and TMP123 are optimal for low power applications, with a 0.5s conversion period for reduced power consumption. The TMP121 and TMP123 are specified for a supply voltage range of 2.7V to 5.5V, and also feature a hardware shutdown to provide additional power savings.

The TMP121 and TMP123 require no external components for operation, though a 0.1µF supply bypass capacitor is recommended. Figure 1 shows typical connections for the TMP121 and TMP123.

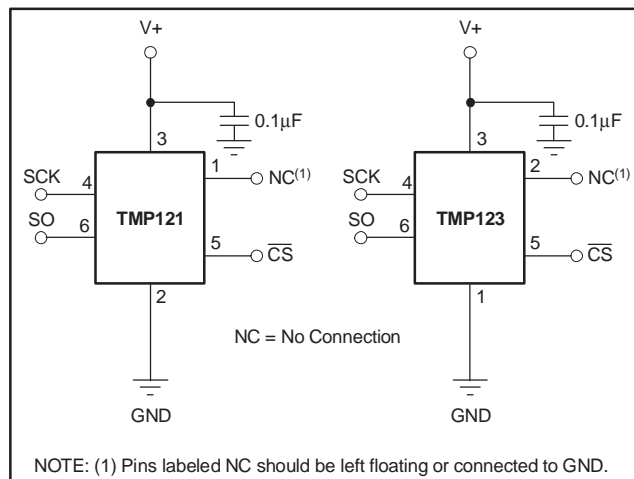

**Figure 1. Typical Connections of the TMP121 and TMP123**

The sensing device of both the TMP121 and TMP123 is the chip itself; the die flag of the lead frame is thermally connected to pin 2 of the TMP121, and of the TMP123. Thermal paths run through the package leads as well as the plastic package, and the lower thermal resistance of metal causes the leads to provide the primary thermal path. The GND pin (pin 2) of the TMP121 and the NC pin (pin 2) of the TMP123 are thermally connected to the metal lead frame, and are the best choice for thermal input.

To maintain accuracy in applications requiring air or surface temperature measurement, care should be taken to isolate the package and leads from ambient air temperature.

## TEMPERATURE REGISTER

The Temperature Register of the TMP121 and TMP123 is a 16-bit, signed read-only register that stores the output of the most recent conversion. Up to 16 bits can be read to obtain data and are described in Table 1. The first 13 bits are used to indicate temperature with bits D2 = 0, and D1, D0 in a high impedance state. Data format for temperature is summarized in Table 2. Following power-up or reset, the Temperature Register will read 0°C until the first conversion is complete.

D15	D14	D13	D12	D11	D10	D9	D8
T12	T11	T10	T9	T8	T7	T6	T5
D7	D6	D5	D4	D3	D2	D1	D0
T4	T3	T2	T1	T0	0	Z	Z

**Table 1. Temperature Register**

TEMPERATURE (°C)	DIGITAL OUTPUT <sup>(1)</sup> (BINARY)	HEX
150	0100 1011 0000 0000	4B00
125	0011 1110 1000 0000	3E80
25	0000 1100 1000 0000	0C80
0.0625	0000 0000 0000 1000	0008
0	0000 0000 0000 0000	0000
-0.0625	1111 1111 1111 1000	FFF8
-25	1111 0011 1000 0000	F380
-55	1110 0100 1000 0000	E480

(1) The last two bits are high impedance and are shown as 00 in the table.

**Table 2. Temperature Data Format**

## COMMUNICATING WITH THE TMP121

The TMP121 and TMP123 continuously convert temperatures to digital data while  $\overline{CS}$  is high.  $\overline{CS}$  must be high for a minimum of one conversion time (320ms max) to update the temperature data. Reading temperature data from the TMP121 and TMP123 is initiated by pulling  $\overline{CS}$  low, which will cause any conversion in progress to terminate, and place the device into analog shutdown. Quiescent current is reduced to 1µA during analog shutdown. Once  $\overline{CS}$  is pulled low, temperature data from the last completed conversion prior to dropping  $\overline{CS}$  is latched into the shift register and clocked out at SO on the falling SCK edge. The 16-bit data word is clocked out sign bit first, followed by the MSB. Any portion of the 16-bit word can be read before raising  $\overline{CS}$ . The TMP121 and TMP123 typically require 0.25s to complete a conversion and consume 50µA of current during this period. If  $\overline{CS}$  is held high for longer than one conversion time period the TMP121 and TMP123 will go into idle mode for 0.25s, requiring only 20µA of current. A new conversion begins every 0.5s. Figure 2 describes the conversion timing for the TMP121 and TMP123.

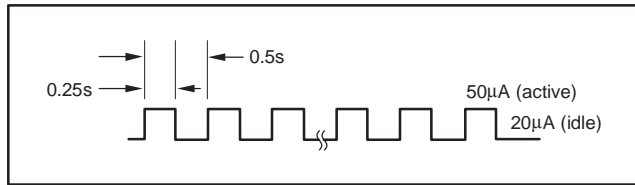

**Figure 2. Conversion Time and Period**

The serial data of the TMP121 and TMP123 consists of 12-bit plus sign temperature data followed by a confirmation bit and two high impedance bits. Data is transmitted in Binary Two's Complement format. Figure 3 describes the output data of the TMP121 and TMP123.

**Timing Diagrams**

The TMP121 and TMP123 are SPI-compatible. Figure 4 and Figure 5 describe the various timing requirements, with parameters defined in Table 3.

PARAMETER	MIN	MAX	UNITS
SCK Period	$t_1$	100	ns
SCK Falling Edge to Output Data Delay	$t_2$	30	ns
CS to Rising Edge SCK Set-Up Time	$t_3$	40	ns
CS to Output Data Delay	$t_4$	30	ns
CS Rising Edge to Output High Impedance	$t_5$	30	ns

**Table 3. Timing Description**

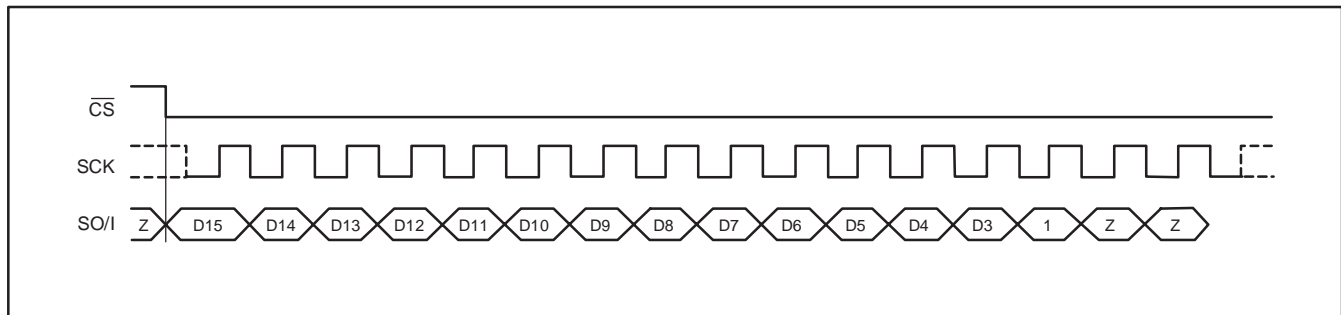

**Figure 3. Data READ**

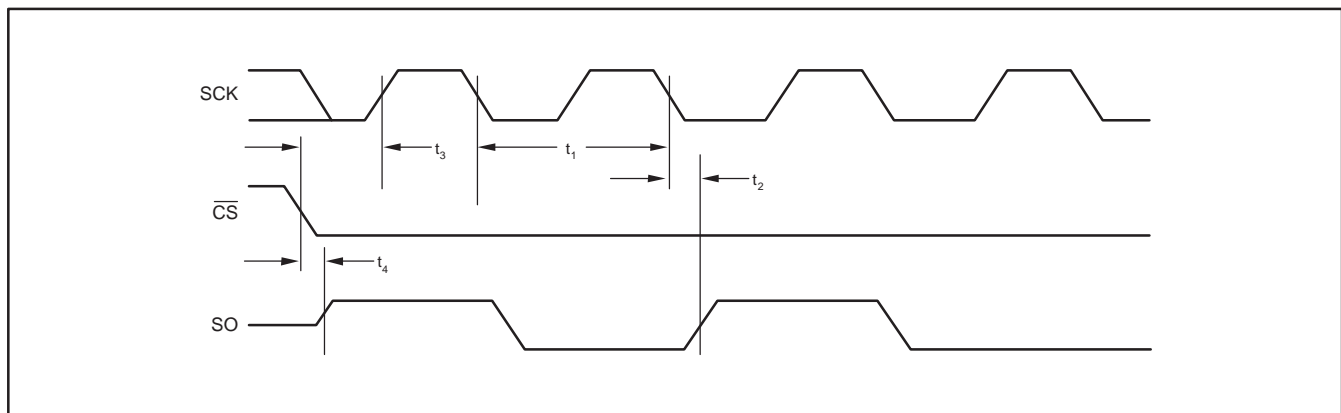

**Figure 4. Output Data Timing Diagram**

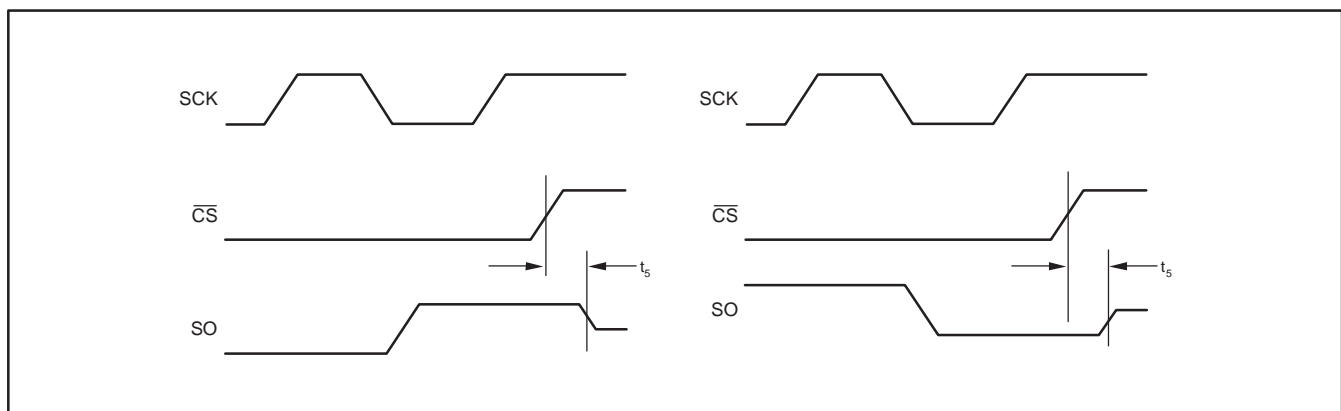

**Figure 5. High Impedance Output Timing Diagram**

**PACKAGING INFORMATION**

Orderable Device	Status <sup>(1)</sup>	Package Type	Package Drawing	Pins	Package Qty	Eco Plan <sup>(2)</sup>	Lead/Ball Finish	MSL Peak Temp <sup>(3)</sup>
TMP121AIDBVR	ACTIVE	SOT-23	DBV	6	3000	Green (RoHS & no Sb/Br)	CU NIPDAU	Level-2-260C-1 YEAR
TMP121AIDBVRG4	ACTIVE	SOT-23	DBV	6	3000	Green (RoHS & no Sb/Br)	CU NIPDAU	Level-2-260C-1 YEAR
TMP121AIDBVT	ACTIVE	SOT-23	DBV	6	250	Green (RoHS & no Sb/Br)	CU NIPDAU	Level-2-260C-1 YEAR
TMP121AIDBVTG4	ACTIVE	SOT-23	DBV	6	250	Green (RoHS & no Sb/Br)	CU NIPDAU	Level-2-260C-1 YEAR
TMP123AIDBVR	ACTIVE	SOT-23	DBV	6	3000	Green (RoHS & no Sb/Br)	CU NIPDAU	Level-2-260C-1 YEAR
TMP123AIDBVRG4	ACTIVE	SOT-23	DBV	6	3000	Green (RoHS & no Sb/Br)	CU NIPDAU	Level-2-260C-1 YEAR
TMP123AIDBVT	ACTIVE	SOT-23	DBV	6	250	Green (RoHS & no Sb/Br)	CU NIPDAU	Level-2-260C-1 YEAR
TMP123AIDBVTG4	ACTIVE	SOT-23	DBV	6	250	Green (RoHS & no Sb/Br)	CU NIPDAU	Level-2-260C-1 YEAR

<sup>(1)</sup> The marketing status values are defined as follows:

**ACTIVE:** Product device recommended for new designs.

**LIFEBUY:** TI has announced that the device will be discontinued, and a lifetime-buy period is in effect.

**NRND:** Not recommended for new designs. Device is in production to support existing customers, but TI does not recommend using this part in a new design.

**PREVIEW:** Device has been announced but is not in production. Samples may or may not be available.

**OBSOLETE:** TI has discontinued the production of the device.

<sup>(2)</sup> Eco Plan - The planned eco-friendly classification: Pb-Free (RoHS), Pb-Free (RoHS Exempt), or Green (RoHS & no Sb/Br) - please check <http://www.ti.com/productcontent> for the latest availability information and additional product content details.

**TBD:** The Pb-Free/Green conversion plan has not been defined.

**Pb-Free (RoHS):** TI's terms "Lead-Free" or "Pb-Free" mean semiconductor products that are compatible with the current RoHS requirements for all 6 substances, including the requirement that lead not exceed 0.1% by weight in homogeneous materials. Where designed to be soldered at high temperatures, TI Pb-Free products are suitable for use in specified lead-free processes.

**Pb-Free (RoHS Exempt):** This component has a RoHS exemption for either 1) lead-based flip-chip solder bumps used between the die and package, or 2) lead-based die adhesive used between the die and leadframe. The component is otherwise considered Pb-Free (RoHS compatible) as defined above.

**Green (RoHS & no Sb/Br):** TI defines "Green" to mean Pb-Free (RoHS compatible), and free of Bromine (Br) and Antimony (Sb) based flame retardants (Br or Sb do not exceed 0.1% by weight in homogeneous material)

<sup>(3)</sup> MSL, Peak Temp. -- The Moisture Sensitivity Level rating according to the JEDEC industry standard classifications, and peak solder temperature.

**Important Information and Disclaimer:**The information provided on this page represents TI's knowledge and belief as of the date that it is provided. TI bases its knowledge and belief on information provided by third parties, and makes no representation or warranty as to the accuracy of such information. Efforts are underway to better integrate information from third parties. TI has taken and continues to take reasonable steps to provide representative and accurate information but may not have conducted destructive testing or chemical analysis on incoming materials and chemicals. TI and TI suppliers consider certain information to be proprietary, and thus CAS numbers and other limited information may not be available for release.

In no event shall TI's liability arising out of such information exceed the total purchase price of the TI part(s) at issue in this document sold by TI to Customer on an annual basis.

DBV (R-PDSO-G6)

PLASTIC SMALL-OUTLINE PACKAGE

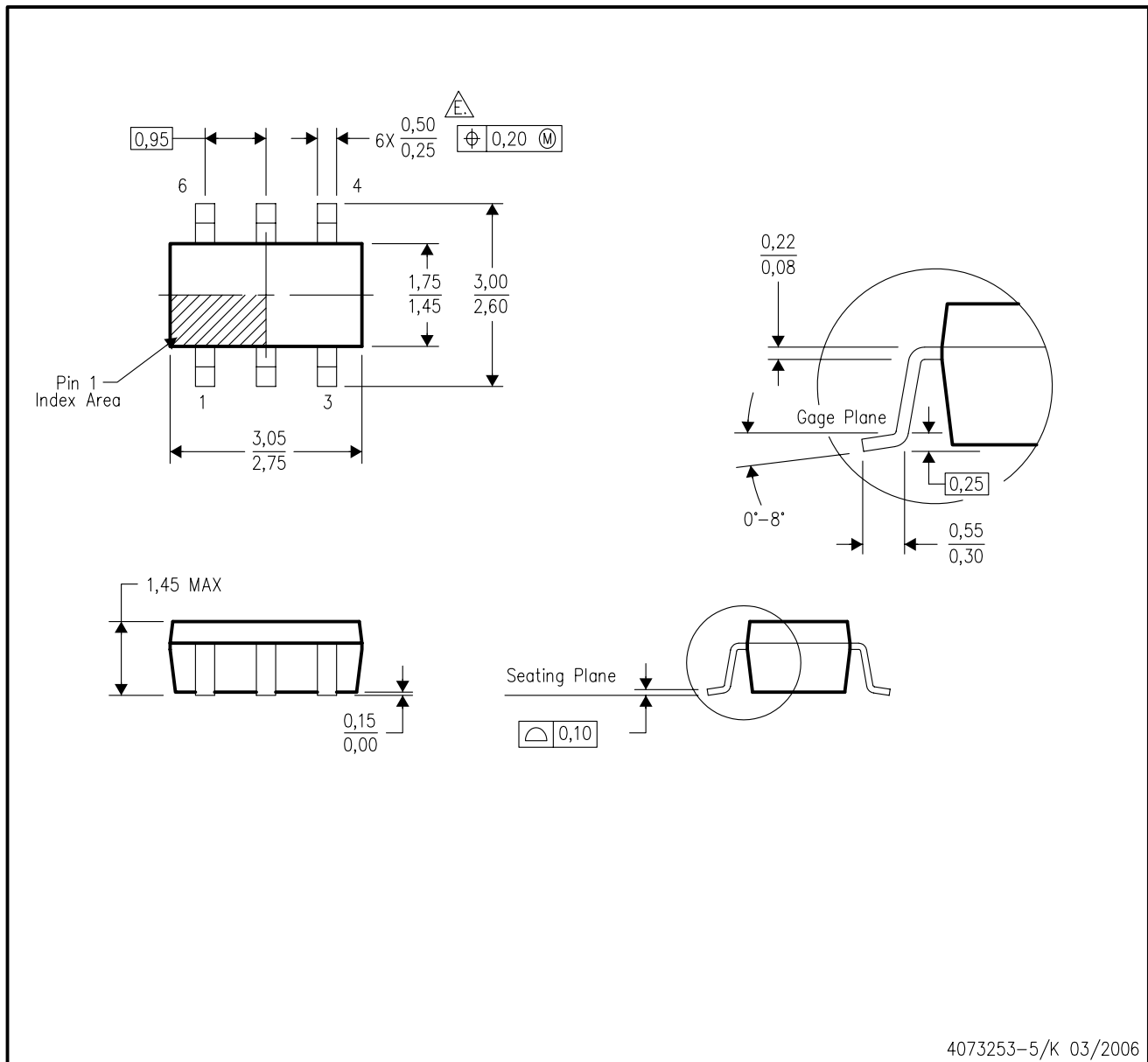

- NOTES:
- A. All linear dimensions are in millimeters.
  - B. This drawing is subject to change without notice.
  - C. Body dimensions do not include mold flash or protrusion. Mold flash and protrusion shall not exceed 0.15 per side.
  - D. Leads 1,2,3 may be wider than leads 4,5,6 for package orientation.
- $\triangle$  Falls within JEDEC MO-178 Variation AB, except minimum lead width.

## IMPORTANT NOTICE

Texas Instruments Incorporated and its subsidiaries (TI) reserve the right to make corrections, modifications, enhancements, improvements, and other changes to its products and services at any time and to discontinue any product or service without notice. Customers should obtain the latest relevant information before placing orders and should verify that such information is current and complete. All products are sold subject to TI's terms and conditions of sale supplied at the time of order acknowledgment.

TI warrants performance of its hardware products to the specifications applicable at the time of sale in accordance with TI's standard warranty. Testing and other quality control techniques are used to the extent TI deems necessary to support this warranty. Except where mandated by government requirements, testing of all parameters of each product is not necessarily performed.

TI assumes no liability for applications assistance or customer product design. Customers are responsible for their products and applications using TI components. To minimize the risks associated with customer products and applications, customers should provide adequate design and operating safeguards.

TI does not warrant or represent that any license, either express or implied, is granted under any TI patent right, copyright, mask work right, or other TI intellectual property right relating to any combination, machine, or process in which TI products or services are used. Information published by TI regarding third-party products or services does not constitute a license from TI to use such products or services or a warranty or endorsement thereof. Use of such information may require a license from a third party under the patents or other intellectual property of the third party, or a license from TI under the patents or other intellectual property of TI.

Reproduction of information in TI data books or data sheets is permissible only if reproduction is without alteration and is accompanied by all associated warranties, conditions, limitations, and notices. Reproduction of this information with alteration is an unfair and deceptive business practice. TI is not responsible or liable for such altered documentation.

Resale of TI products or services with statements different from or beyond the parameters stated by TI for that product or service voids all express and any implied warranties for the associated TI product or service and is an unfair and deceptive business practice. TI is not responsible or liable for any such statements.

Following are URLs where you can obtain information on other Texas Instruments products and application solutions:

<b>Products</b>		<b>Applications</b>	
Amplifiers	<a href="http://amplifier.ti.com">amplifier.ti.com</a>	Audio	<a href="http://www.ti.com/audio">www.ti.com/audio</a>
Data Converters	<a href="http://dataconverter.ti.com">dataconverter.ti.com</a>	Automotive	<a href="http://www.ti.com/automotive">www.ti.com/automotive</a>
DSP	<a href="http://dsp.ti.com">dsp.ti.com</a>	Broadband	<a href="http://www.ti.com/broadband">www.ti.com/broadband</a>
Interface	<a href="http://interface.ti.com">interface.ti.com</a>	Digital Control	<a href="http://www.ti.com/digitalcontrol">www.ti.com/digitalcontrol</a>
Logic	<a href="http://logic.ti.com">logic.ti.com</a>	Military	<a href="http://www.ti.com/military">www.ti.com/military</a>
Power Mgmt	<a href="http://power.ti.com">power.ti.com</a>	Optical Networking	<a href="http://www.ti.com/opticalnetwork">www.ti.com/opticalnetwork</a>
Microcontrollers	<a href="http://microcontroller.ti.com">microcontroller.ti.com</a>	Security	<a href="http://www.ti.com/security">www.ti.com/security</a>
Low Power Wireless	<a href="http://www.ti.com/lpw">www.ti.com/lpw</a>	Telephony	<a href="http://www.ti.com/telephony">www.ti.com/telephony</a>
		Video & Imaging	<a href="http://www.ti.com/video">www.ti.com/video</a>
		Wireless	<a href="http://www.ti.com/wireless">www.ti.com/wireless</a>

Mailing Address: Texas Instruments  
Post Office Box 655303 Dallas, Texas 75265