

CUSTOMER:	REF NO :	
DESCRIPTION:	SMT73-100K	PAGE: 1/5

VERSION:A

Compliant RoHS

SPECIFICATION

DIMENSION: mm

A	B	C	P1	P2	P3
7.8±0.3	7.0±0.3	3.2±0.5	2.85	2.10	7.25

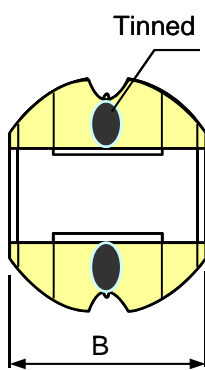

Bottom View

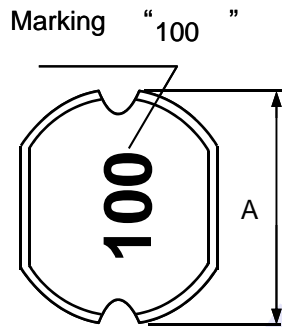

Top View

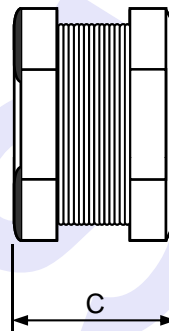

C

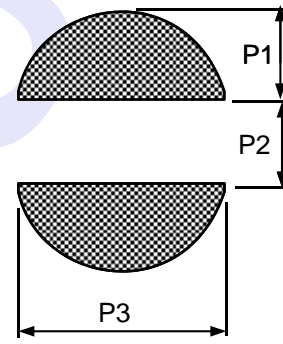

Pad Map

ELECTRONIC CHARACTERISTICS

INDUCTANCE CH-100LCR/f=1KHz/0.25V	DCR at25°C CH-502AC	DCI CH-301A +CH-100LCR	WIRE UEW	TURNS (Ref)	Rated Current (A)
10μH±10%	80m max	L2.1A L0A×80%	Ø0.34mm	15	2.1

APP	CHK	DRG

SAMPLE NO.	ENDW103M1010TA
MATSUTA NO.	68-073100320Q
SPEC. NO.	
ISSUE DATE.	2011/05/24

MATSUTA CO.,LTD.

Flat 15, 10/F, Block B, Tonic Industrial Centre,
19 Lam Hing Street, Kowloon Bay, Hong Kong.

Tel: (852) 2796 6693

Fax: (852) 2796 3530, 2754 5674

E-mail: matsuta@matsuta.com.hk

Web site: <http://www.matsuta.com>

CUSTOMER:	<i>REF NO :</i>		
DESCRIPTION:	SMT73-100K	VERSION: A	PAGE: 2/5

SPECIFICATION

MATERIALS LIST:

Compliant RoHS

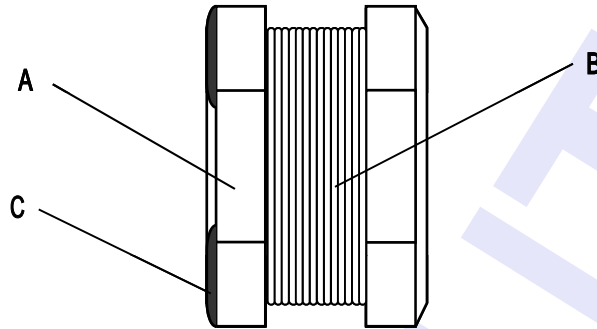

NO	ITEM	MATERIALS	MANUFACTURER	UL FILE NO
A	CORE	DL5 DR7.8x3.5 OR EQUIVALENT	TAK FERRITE CO.,LTD	N/A
B	WIRE	UEW 130°C	FENG CHING METAL CORP	E172395
C	SOLDER	M4	NIHON GENMA	N/A

APP	CHK	DRG

SAMPLE NO.	ENDW103M1010TA
MATSUTA NO.	68-073100320Q
SPEC. NO.	
ISSUE DATE.	2011/05/24

MATSUTA CO.,LTD.

Flat 15, 10/F, Block B, Tonic Industrial Centre,
19 Lam Hing Street, Kowloon Bay, Hong Kong.

Tel: (852) 2796 6693

Fax: (852) 2796 3530, 2754 5674

E-mail: matsuta@matsuta.com.hk

Web site: <http://www.matsuta.com>

CUSTOMER:		REF NO:
DESCRIPTION:	SMT73-100K	

VERSION:A | PAGE: 3/5

SPECIFICATION

Compliant RoHS

Dimensions for carrier tape with packed quantities (unit: mm)

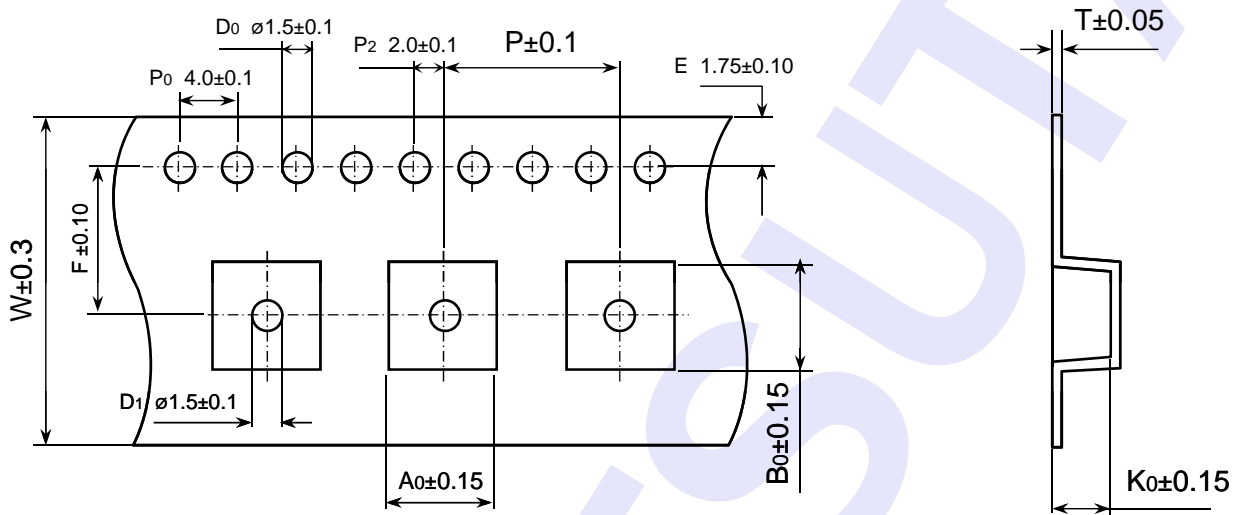

TYPE	DIMENSIONS							Reel	Quantities (PCS/Reel)	Quantities (Reel/cased)
	A ₀	B ₀	W	P	T	F	K ₀			
SMT73	7.30	8.10	16.00	12.00	0.40	7.50	5.30	330×16	750.00	4 / 3000

APP	CHK	DRG

SAMPLE NO.	ENDW103M1010TA
MATSUTA NO.	68-073100320Q
SPEC. NO.	
ISSUE DATE.	2011/05/24

MATSUTA CO.,LTD.
 Flat 15, 10/F, Block B, Tonic Industrial Centre,
 19 Lam Hing Street, Kowloon Bay, Hong Kong.
 Tel: (852) 2796 6693
 Fax: (852) 2796 3530, 2754 5674
 E-mail: matsuta@matsuta.com.hk
 Web site: <http://www.matsuta.com>

CUSTOMER:	REF NO :
DESCRIPTION:	SMT73-100K

VERSION:A | PAGE: 4/5

SPECIFICATION

Compliant RoHS

DIMENSION: mm

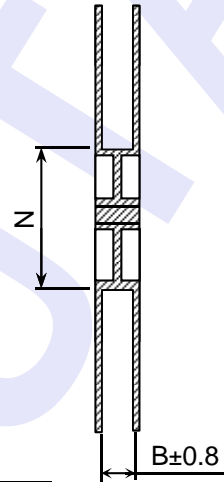
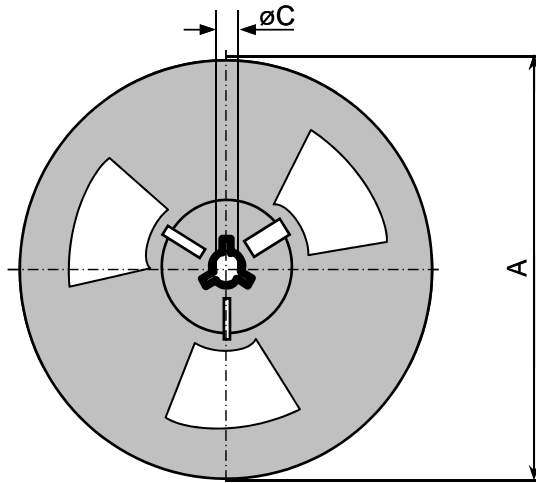

TYPE	A	B	C	N
330×16	330	16.8	13.5	100

END

START

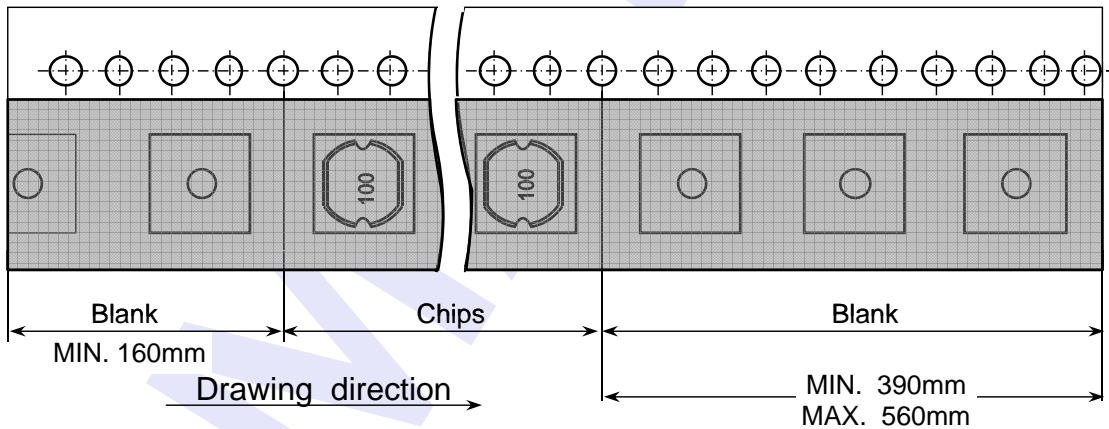

APP	CHK	DRG

SAMPLE NO.	ENDW103M1010TA
MATSUTA NO.	68-073100320Q
SPEC. NO.	
ISSUE DATE.	2011/05/24

MATSUTA CO.,LTD.

Flat 15, 10/F, Block B, Tonic Industrial Centre,
19 Lam Hing Street, Kowloon Bay, Hong Kong.

Tel: (852) 2796 6693

Fax: (852) 2796 3530, 2754 5674

E-mail: matsuta@matsuta.com.hk

Web site: <http://www.matsuta.com>

CUSTOMER:	REF NO :		
DESCRIPTION:	SMT73-100K	VERSION:A	PAGE: 5/5

SPECIFICATION

Compliant RoHS

Packaging of the box (UNIT:mm)

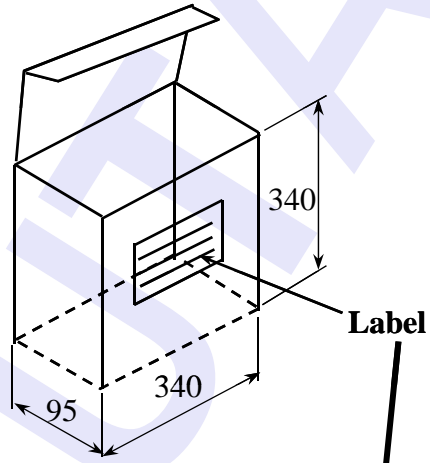
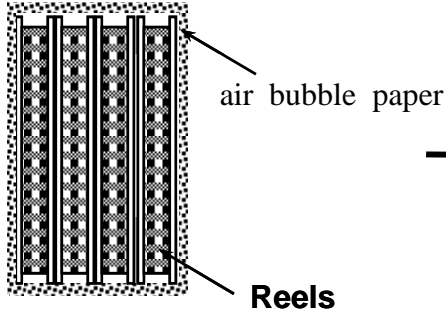

D06 (x5PCS)

inner carton box

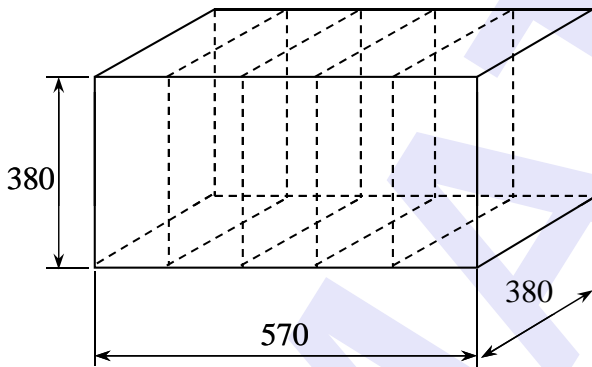

outer carton box

MATSUTA CO. , LTD.

ITEM		
PART NO.		
CUSTOMER		
LOT NO.		
QTY.		Salesman

TEL: (00852)27966693

APP	CHK	DRG

SAMPLE NO.	ENDW103M1010TA
MATSUTA NO.	68-073100320Q
SPEC. NO.	
ISSUE DATE.	2011/05/24

MATSUTA CO.,LTD.

Flat 15, 10/F, Block B, Tonic Industrial Centre,
19 Lam Hing Street, Kowloon Bay, Hong Kong.

Tel: (852) 2796 6693

Fax: (852) 2796 3530, 2754 5674

E-mail: matsuta@matsuta.com.hk

Web site: <http://www.matsuta.com>