

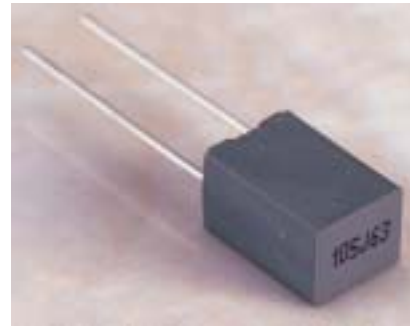

外形图 Outline Drawing

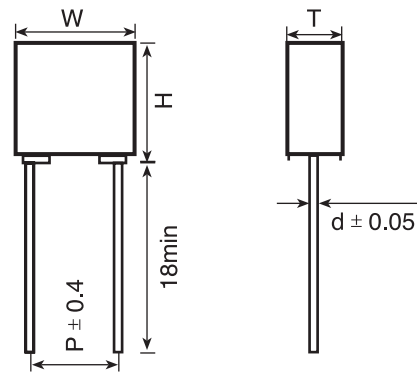

特点

- 由于采用叠片式结构，因而体积小，抗脉冲能力强

Features

- High dv/dt ability and small size due to stacked construction

技术要求 Specifications

引用标准 Reference Standard	GB7332 (IEC 60384-2)		
气候类别 Climatic Category	55/100/56		
额定温度 Rated Temperature	85℃		
工作温度范围 Operating Temperature Range	-55℃~105℃ (+85℃ to +105℃: decreasing factor 1.25% per ℃ for V _R (DC))		
额定电压 Rated Voltage	50/63V、100V、250V、400V、500V、630V		
电容量范围 Capacitance Range	0.0010 μF~1.5 μF		
电容量偏差 Capacitance Tolerance	± 5%(J), ± 10%(K), ± 20%(M)		
耐电压 Voltage Proof	I 型: 1.6U _R (5s)、II 型: 1.4U _R (5s)		
损耗角正切 Dissipation Factor	测试频率 Frequency	C _R ≤ 0.1 μF	C _R > 0.1 μF
	1kHz	≤ 1.0%	≤ 1.0%
	10kHz	≤ 1.5%	≤ 1.5%
	100kHz	≤ 3.0%	—
绝缘电阻 Insulation Resistance	U _R > 100V	≥ 30 000MΩ, C _R ≤ 0.33μF (20℃, 100V, 1min)	
	U _R ≤ 100V	≥ 15 000MΩ, C _R ≤ 0.33μF (20℃, 10V, 1min) ≥ 5 000s, C _R > 0.33μF	
最大脉冲爬升速率 Maximum Pulse Rise Time (dv/dt): 若实际工作电压U比额定电压U _R 低, 电容器可工作在更高的dv/dt场合。这样dv/dt允许值应为右表值乘以U _R /U。 If the working voltage (U) is lower than the rated voltage (U _R), the capacitor can be worked at a higher dv/dt. In this case, the maximum allowed dv/dt is obtain by multiplying the right value with U _R /U.	U _R (V)	dv/dt(V/μs)	
	50/63	250	
	100	300	
	250	400	
	400	600	
	500	700	
630	800		

外形尺寸 Dimensions(mm)

电容器厚度(Capacitor Thickness)T	≤ 3.5	> 3.5
引出线直径(Lead Wire Dia.)d ± 0.05	0.5	0.6
外型尺寸偏差(Dimension Tolerance: W,H,T)	± 0.2	± 0.4

I 型 (Pattern I)

电容量 (μF)	50/63VDC			100VDC			250VDC			400VDC			500VDC			630VDC		
	W	H	T	W	H	T	W	H	T	W	H	T	W	H	T	W	H	T
0.0010	7.2	6.5	2.5	7.2	6.5	2.5	7.2	6.5	2.5	7.2	6.5	2.5	7.2	6.5	2.5	7.2	6.5	2.5
0.0012	7.2	6.5	2.5	7.2	6.5	2.5	7.2	6.5	2.5	7.2	6.5	2.5	7.2	6.5	2.5	7.2	6.5	2.5
0.0015	7.2	6.5	2.5	7.2	6.5	2.5	7.2	6.5	2.5	7.2	6.5	2.5	7.2	6.5	2.5	7.2	6.5	2.5
0.0018	7.2	6.5	2.5	7.2	6.5	2.5	7.2	6.5	2.5	7.2	6.5	2.5	7.2	6.5	2.5	7.2	7.5	3.5
0.0022	7.2	6.5	2.5	7.2	6.5	2.5	7.2	6.5	2.5	7.2	6.5	2.5	7.2	6.5	2.5	7.2	7.5	3.5
0.0027	7.2	6.5	2.5	7.2	6.5	2.5	7.2	6.5	2.5	7.2	6.5	2.5	7.2	6.5	2.5	7.2	7.5	3.5
0.0033	7.2	6.5	2.5	7.2	6.5	2.5	7.2	6.5	2.5	7.2	6.5	2.5	7.2	7.5	3.5	7.2	7.5	3.5
0.0039	7.2	6.5	2.5	7.2	6.5	2.5	7.2	6.5	2.5	7.2	6.5	2.5	7.2	7.5	3.5	7.2	7.5	3.5
0.0047	7.2	6.5	2.5	7.2	6.5	2.5	7.2	6.5	2.5	7.2	6.5	2.5	7.2	7.5	3.5	7.2	9.5	4.5
0.0056	7.2	6.5	2.5	7.2	6.5	2.5	7.2	6.5	2.5	7.2	7.5	3.5	7.2	7.5	3.5	7.2	9.5	4.5
0.0068	7.2	6.5	2.5	7.2	6.5	2.5	7.2	6.5	2.5	7.2	7.5	3.5	7.2	9.5	4.5	7.2	9.5	4.5
0.0082	7.2	6.5	2.5	7.2	6.5	2.5	7.2	6.5	2.5	7.2	7.5	3.5	7.2	9.5	4.5	7.2	9.5	4.5
0.010	7.2	6.5	2.5	7.2	6.5	2.5	7.2	6.5	2.5	7.2	7.5	3.5	7.2	9.5	4.5	7.2	10.0	5.0
0.012	7.2	6.5	2.5	7.2	6.5	2.5	7.2	6.5	2.5	7.2	9.5	4.5	7.2	9.5	4.5	7.2	11.0	6.0
0.015	7.2	6.5	2.5	7.2	6.5	2.5	7.2	6.5	2.5	7.2	9.5	4.5	7.2	10.0	5.0	7.2	11.0	6.0
0.018	7.2	6.5	2.5	7.2	6.5	2.5	7.2	6.5	2.5	7.2	9.5	4.5	7.2	11.0	6.0			
0.022	7.2	6.5	2.5	7.2	6.5	2.5	7.2	7.5	3.5	7.2	10.0	5.0	7.2	11.0	6.0			
0.027	7.2	6.5	2.5	7.2	6.5	2.5	7.2	7.5	3.5	7.2	11.0	6.0	7.2	11.0	6.0			
0.033	7.2	6.5	2.5	7.2	6.5	2.5	7.2	7.5	3.5	7.2	11.0	6.0						
0.039	7.2	6.5	2.5	7.2	6.5	2.5	7.2	7.5	3.5	7.2	11.0	6.0						
0.047	7.2	6.5	2.5	7.2	6.5	2.5	7.2	9.5	4.5	7.2	11.0	6.0						
0.056	7.2	6.5	2.5	7.2	6.5	2.5	7.2	9.5	4.5									
0.068	7.2	6.5	2.5	7.2	6.5	2.5	7.2	9.5	4.5									
0.082	7.2	6.5	2.5	7.2	6.5	2.5	7.2	10.0	5.0									
0.10	7.2	6.5	2.5	7.2	7.5	3.5	7.2	10.0	5.0									
0.12	7.2	6.5	2.5	7.2	9.5	4.5	7.2	11.0	6.0									
0.15	7.2	7.5	3.5	7.2	9.5	4.5	7.2	11.0	6.0									
0.18	7.2	7.5	3.5	7.2	9.5	4.5												
0.22	7.2	7.5	3.5	7.2	10.0	5.0												
0.27	7.2	9.5	4.5	7.2	10.0	5.0												
0.33	7.2	9.5	4.5	7.2	11.0	6.0												
0.39	7.2	9.5	4.5	7.2	11.0	6.0												
0.47	7.2	10.0	5.0	7.2	11.0	6.0												
0.56	7.2	10.0	5.0	7.2	11.0	6.0												
0.68	7.2	11.0	6.0															
0.82	7.2	11.0	6.0															
1.0	7.2	11.0	6.0															

II 型 (Pattern II)

电容量 (μF)	50/63VDC			100VDC			电容量 (μF)	50/63VDC			100VDC		
	W	H	T	W	H	T		W	H	T	W	H	T
0.10				7.2	6.5	2.5	0.39	7.2	7.5	3.5	7.2	9.5	4.5
0.12				7.2	6.5	2.5	0.47	7.2	7.5	3.5	7.2	10.0	5.0
0.15	7.2	6.5	2.5	7.2	7.5	3.5	0.56	7.2	9.5	4.5	7.2	10.0	5.0
0.18	7.2	6.5	2.5	7.2	7.5	3.5	0.68	7.2	9.5	4.5	7.2	11.0	6.0
0.22	7.2	6.5	2.5	7.2	7.5	3.5	0.82	7.2	9.5	4.5	7.2	11.0	6.0
0.27	7.2	6.5	2.5	7.2	9.5	4.5	1.0	7.2	10.0	5.0	7.2	11.0	6.0
0.33	7.2	7.5	3.5	7.2	9.5	4.5	1.5	7.2	11.0	6.0			