



TECHNICAL CRYSTAL (CHINA) LIMITED

德力高石英(中國)有限公司

Tel: (852) 2688 2033
Fax: (852) 2688 2031
E-mail: tic@tecko.com
http://www.tecko.com

Unit 750, Block F, Wah Lok Industrial Centre, 31-35 Shan Mei Street, Fotan, N.T., Hong Kong
香港新界火炭山尾街31-35號華樂工業中心F座7樓50室

Preview of Crystal Ceramic Glass SMD (5x3.2) 2 Pads

Part #: 27MFEDGNEKA-SM50322G

1. GENERAL

- | | |
|----------------------------|----------------------------------|
| 1.1 Center Frequency: | 27.000 MHz |
| 1.2 Holder Type: | Crystal SMD (5x3.2) 2 pads Glass |
| 1.3 Mode of Oscillation: | Fundamental |
| 1.4 Load Capacitance: | 20 +/-0.2pF |
| 1.5 Operating Temperature: | -20°C to +70°C |
| 1.6 Storage Temperature: | -40°C to +85°C |
| 1.7 Drive Level: | 100μW max |

2. DIMENSION (mm):

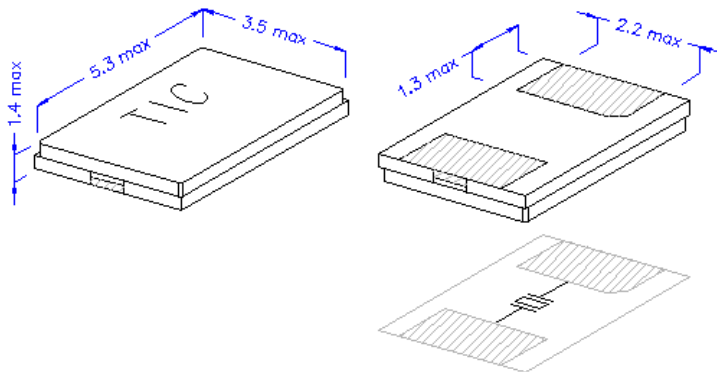

3. ELECTRICAL CHARACTERISTICS

This test shall be performed under the conditions of temperature at 25 +/-3°C.

- | | |
|----------------------------|-------------------------------------|
| 2.1 Frequency Tolerance: | +/-20ppm |
| 2.2 Frequency Stability: | +/-50ppm |
| 2.3 Series Resistance: | 50Ω max |
| 2.4 Shunt Capacitance: | 7.0 pF max |
| 2.5 Insulation Resistance: | 500meg. Ω min / DC 100V +/-15V D.C. |
| 2.6 Aging: | +/-3ppm / 1 st year |
| 2.7 Measuring Instrument: | 250B PI-Network |