

Customer Information Sheet

DRAWING No.: R6505-00 - R6535-00

IF IN DOUBT - ASK

©

NOT TO SCALE

THIRD ANGLE PROJECTION

ALL DIMENSIONS IN mm

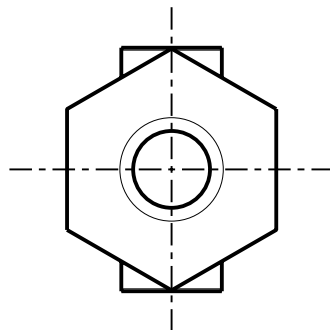
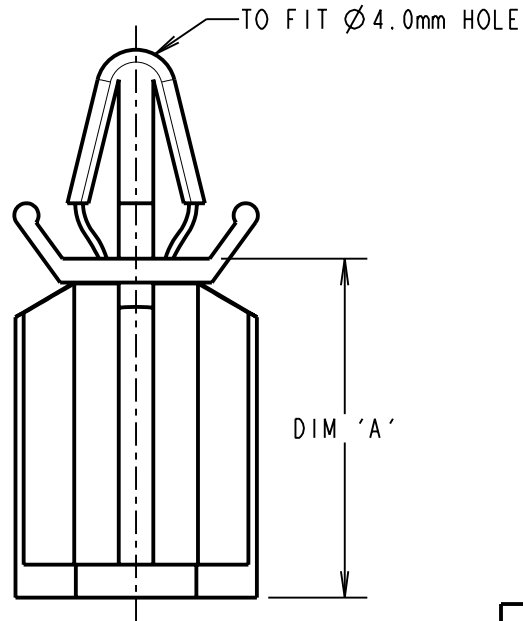
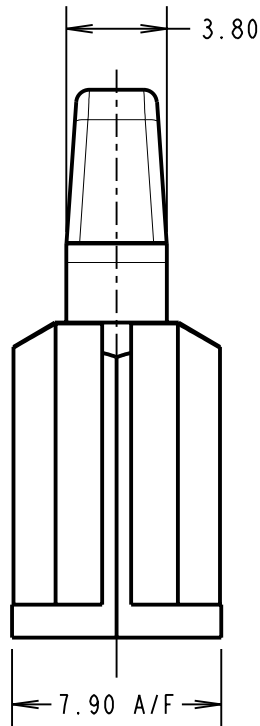

PART No.	DIM 'A'
R6505-00	5.50
R6510-00	9.45
R6513-00	12.80
R6519-00	19.10
R6528-00	28.50
R6535-00	35.00

ORDER CODE: **R65XX-00**
 HEIGHT CODE (SEE TABLE)

CP	4	09.03.10	10702
NAME	ISS.	DATE	C/NOTE
APPROVED: C.PENROSE			
CHECKED:		R.ADDE	
DRAWN:		D.BECK	
CUSTOMER REF.:			
ASSEMBLY DRG:			

- NOTES:
1. ALL TOLERANCES ARE ± 0.50 UNLESS OTHERWISE STATED.
 2. TEMPERATURE RANGE = -40°C TO $+85^{\circ}\text{C}$.
 3. HOLE TO FIT No. 6 (1/8" SCREW. RECOMMENDED MOUNTING HOLE IN PANEL FOR SCREW = $\varnothing 3.00\text{mm}$

HARWIN

HARWIN USA
 TEL: 603 893 5376
 FAX: 603 893 5396
 mis@harwin.com

HARWIN Europe (UK)
 TEL: 023 9231 4545
 FAX: 023 9231 4590
 mis@harwin.co.uk

HARWIN Asia
 TEL: +65 6 779 4909
 FAX: +65 6 779 3868
 mis@harwin.com.sg

THIS DRAWING AND ANY INFORMATION OR DESCRIPTIVE MATTER SET OUT HEREON ARE CONFIDENTIAL AND COPYRIGHT PROPERTY OF THE HARWIN GROUP AND MUST NOT BE DISCLOSED, LOANED, COPIED OR USED FOR MANUFACTURING, TENDERING OR FOR ANY OTHER PURPOSE WITHOUT THEIR WRITTEN PERMISSION.

TOLERANCES
~~X = $\pm 1\text{mm}$~~
~~X.X = $\pm 0.25\text{mm}$~~
~~X.XX = $\pm 0.10\text{mm}$~~
~~X.XXX = $\pm 0.01\text{mm}$~~
 ANGLES = $\pm 5^{\circ}$
 UNLESS STATED

MATERIAL:
 NYLON 66 NATURAL UL94V-2
FINISH: CLEAN
S/AREA: mm²

TITLE:
 SELF LOCKING SPACER
DRAWING NUMBER:
R6505-00 - R6535-00
 SHT 2 OF 2