

Customer Information Sheet

DRAWING No.: IF IN DOUBT - ASK © NOT TO SCALE THIRD ANGLE PROJECTION ALL DIMENSIONS IN mm

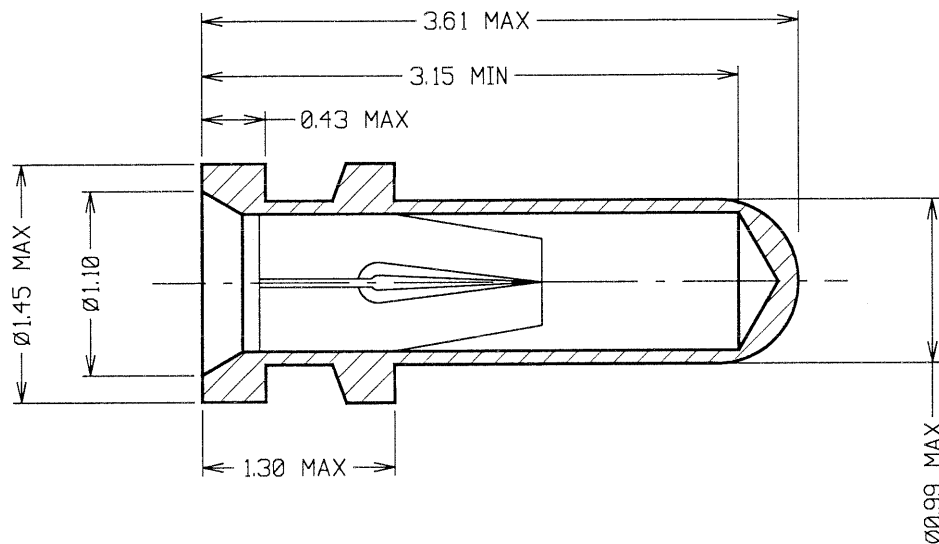

ORDER CODE:
H3155-XX
 FINISH:
 01 - GOLD CLIP, TIN SHELL
 05 - GOLD CLIP, GOLD SHELL
 46 - 100% TIN CLIP, 100% TIN SHELL

SPECIFICATION:

MATERIAL:

CONTACT SHELL = BRASS
 CONTACT CLIP = BERYLLIUM COPPER

FINISH:

01 = 0.1µ GOLD CLIP, 4µ TIN SHELL
 05 = 0.1µ GOLD CLIP, 0.13µ GOLD SHELL
 46 = 1.3µ 100% TIN CLIP, 4µ 100% TIN SHELL

ELECTRICAL:

CURRENT RATING AT 25°C = 2A MAX
 CURRENT RATING AT 85°C = 1.75A MAX
 CONTACT RESISTANCE (INITIAL) = 15 MILLIOHMS MAX
 CONTACT RESISTANCE (AFTER CONDITIONING) = 25 MILLIOHMS MAX

MECHANICAL:

INSERTION FORCE (INITIAL) = 6N MAX, 2N MIN (Ø0.5mm GAUGE)
 WITHDRAWAL FORCE (INITIAL) = 1.5N MIN, 0.5N MIN (Ø0.5mm GAUGE)
 DURABILITY - 01, 05 = 500 OPERATIONS
 46 = 50 OPERATIONS

ENVIRONMENTAL:

OPERATING TEMPERATURE = -55°C TO +125°C
 FOR COMPLETE SPECIFICATION, SEE COMPONENT SPECIFICATION C006XX (LATEST ISSUE).

NOTES:

1. RECOMMENDED PIN LENGTH = 3.15-2.30mm.
2. RECOMMENDED MOUNTING HOLE SIZE = Ø1.10-1.00mm.
3. RECOMMENDED PIN SIZE = Ø0.51-0.46mm.

JMB	10	22.11.06	9575
NAME	ISS.	DATE	C/NOTE
APPROVED: <i>JMB</i>			
CHECKED: <i>NSBC</i>			
DRAWN:		J CLAY	
CUSTOMER REF.:			
ASSEMBLY DRG:			

HARWIN

HARWIN USA TEL: 603 893 5376 FAX: 603 893 5396 mis@harwin.com
 HARWIN Europe (UK) TEL: 023 9231 4545 FAX: 023 9231 4590 mis@harwin.co.uk
 HARWIN Asia TEL: +65 6 779 4909 FAX: +65 6 779 3868 mis@harwin.com.sg

THIS DRAWING AND ANY INFORMATION OR DESCRIPTIVE MATTER SET OUT HEREON ARE CONFIDENTIAL AND COPYRIGHT PROPERTY OF THE HARWIN GROUP AND MUST NOT BE DISCLOSED, LOANED, COPIED OR USED FOR MANUFACTURING, TENDERING OR FOR ANY OTHER PURPOSE WITHOUT THEIR WRITTEN PERMISSION.

TOLERANCES
 X. = ±1mm
 X.X = ±0.25mm
 X.XX = ±0.10mm
 X.XXX = ±0.01mm
 ANGLES = ±5°
 UNLESS STATED

MATERIAL: SEE ABOVE
FINISH: SEE ABOVE
S/AREA: mm²

TITLE: SUB-MINIATURE SOCKET ASSEMBLY
DRAWING NUMBER: H3155-XX

SHT 2 OF 2