

DETAIL A
SCALE 10:1

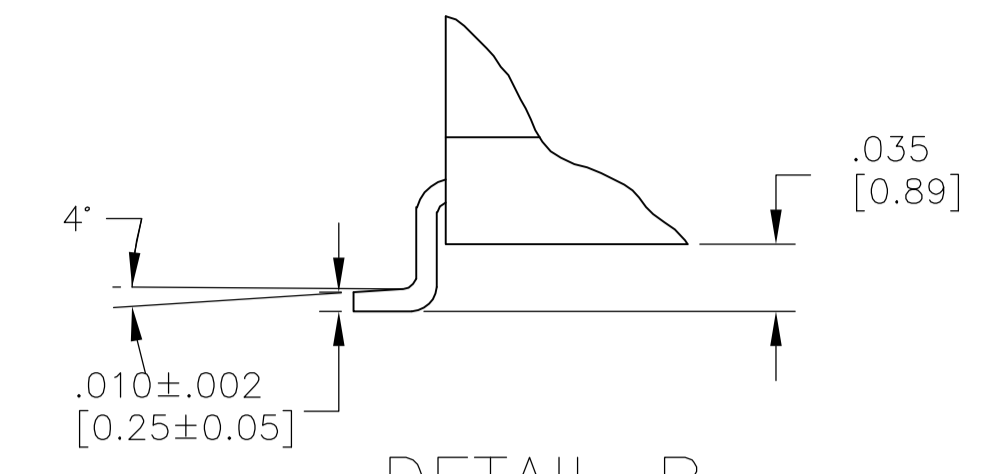

DETAIL B
SCALE 10:1

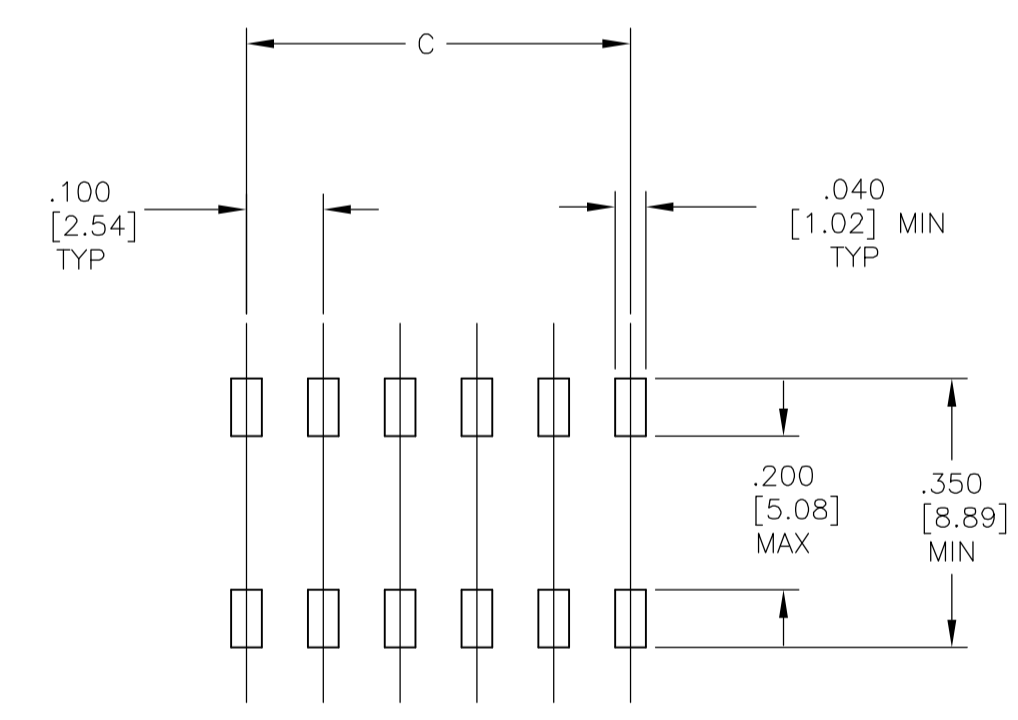
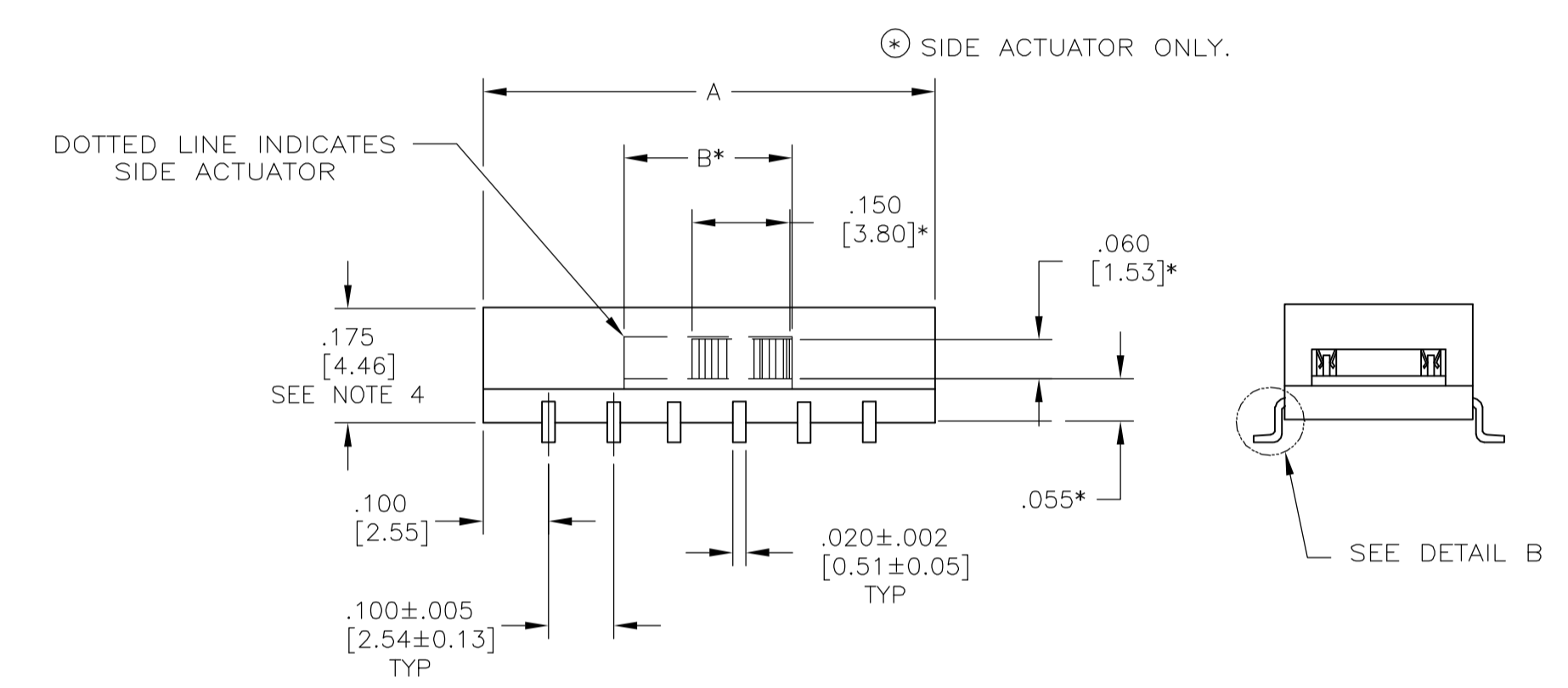
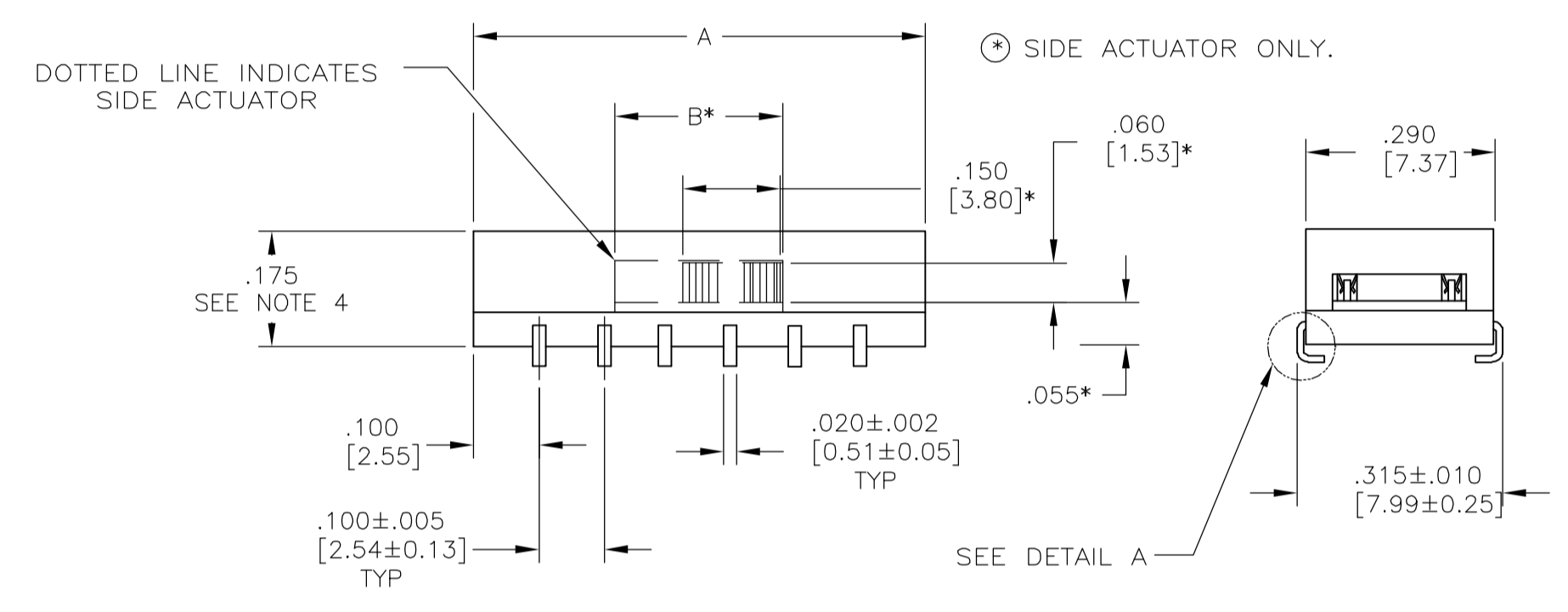

PRINTED CIRCUIT BOARD
PAD LAYOUT

"S" J-LEAD TYPE SURFACE MOUNT

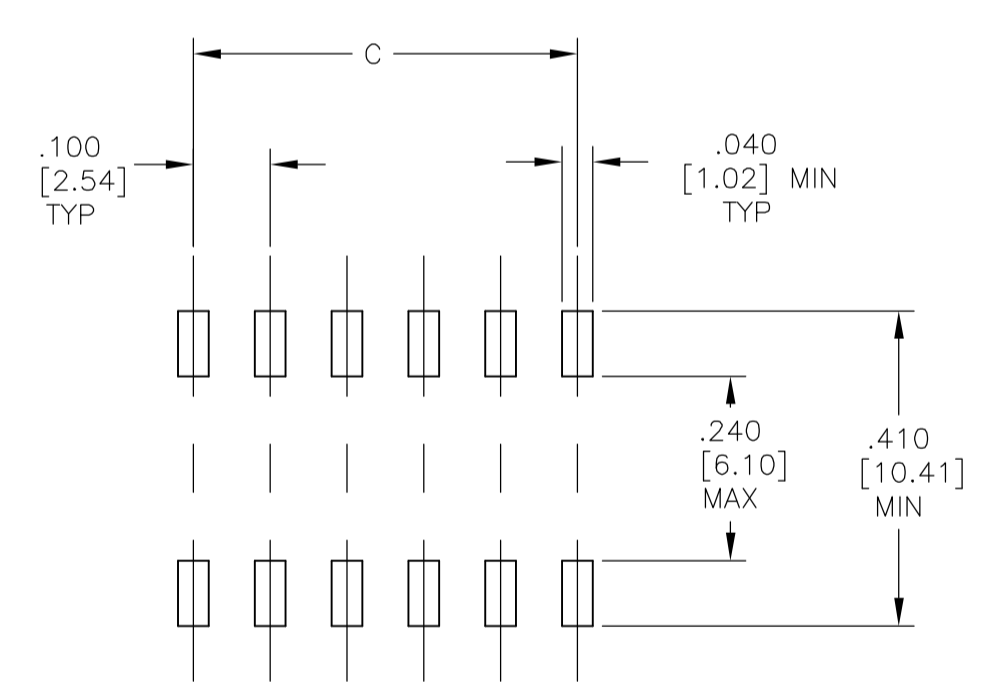

PRINTED CIRCUIT BOARD
PAD LAYOUT

"L" GULL WING TYPE SURFACE MOUNT

THIS DRAWING IS A CONTROLLED DOCUMENT.		DIN B.S.VISWESWARA 20FEB05		Tyco Electronics Corporation Harrisburg, PA 17105-3608	
DIMENSIONS: INCHES [mm]		CHK M.S.SARVER 20FEB05		NAME M.S.SARVER 20FEB05	
TOLERANCES UNLESS OTHERWISE SPECIFIED:		PRODUCT SPEC		SLIDE SWITCH ASF, AUTO-INSERTABLE, THRU-HOLE AND SURFACE MOUNT	
0 PLC ± -		APPLICATION SPEC		-	
1 PLC ± -		SIZE		A1	
2 PLC ± -		CAGE CODE		00779	
3 PLC ± .01(0.25)		DRAWING NO		1825011	
4 PLC ± ± 1'		WEIGHT		-	
MATERIAL SEE SHEET 1		FINISH SEE SHEET 1		CUSTOMER DRAWING	
		SCALE		4:1	
		SHEET		2 OF 2	
		REV		B	