

## 3.1-W MONO FULLY DIFFERENTIAL AUDIO POWER AMPLIFIER

### FEATURES

- Designed for Wireless or Cellular Handsets and PDAs
- 3.1 W Into 3Ω From a 5-V Supply at THD = 10% (Typ)
- Low Supply Current: 4 mA Typ at 5 V
- Shutdown Current: 0.01 μA Typ
- Fast Startup With Minimal Pop
- Only Three External Components
  - Improved PSRR (-80 dB) and Wide Supply Voltage (2.5 V to 5.5 V) for Direct Battery Operation
  - Fully Differential Design Reduces RF Rectification
  - -63 dB CMRR Eliminates Two Input Coupling Capacitors

### APPLICATIONS

- Ideal for Wireless Handsets, PDAs, and Notebook Computers

### DESCRIPTION

The TPA6211A1 is a 3.1-W mono fully-differential amplifier designed to drive a speaker with at least 3-Ω impedance while consuming only 20 mm<sup>2</sup> total printed-circuit board (PCB) area in most applications. The device operates from 2.5 V to 5.5 V, drawing only 4 mA of quiescent supply current. The TPA6211A1 is available in the space-saving 3-mm × 3-mm QFN (DRB) and the 8-pin MSOP (DGN) PowerPAD™ packages.

Features like -80 dB supply voltage rejection from 20 Hz to 2 kHz, improved RF rectification immunity, small PCB area, and a fast startup with minimal pop makes the TPA6211A1 ideal for PDA/smart phone applications.

### APPLICATION CIRCUIT

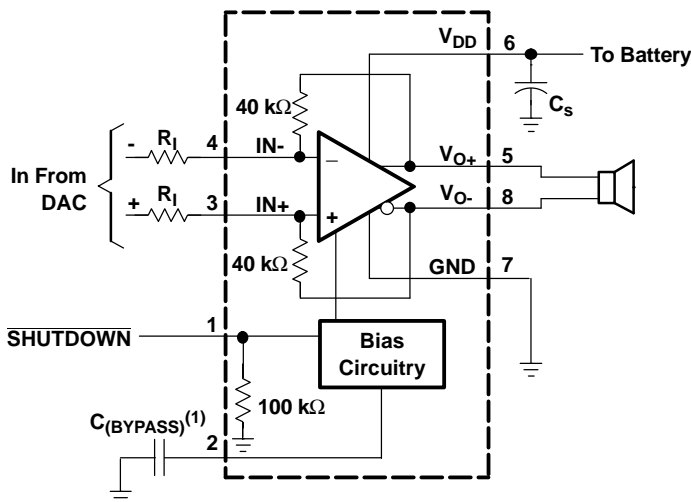

(1) C(BYPASS) is optional.

### 8-PIN QFN (DRB) PACKAGE (TOP VIEW)

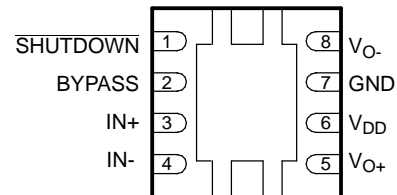

### DGN PACKAGE (TOP VIEW)

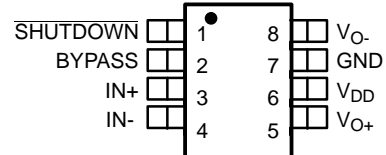

Please be aware that an important notice concerning availability, standard warranty, and use in critical applications of Texas Instruments semiconductor products and disclaimers thereto appears at the end of this data sheet.

PowerPAD is a trademark of Texas Instruments.



These devices have limited built-in ESD protection. The leads should be shorted together or the device placed in conductive foam during storage or handling to prevent electrostatic damage to the MOS gates.

**ORDERING INFORMATION**

T <sub>A</sub>	PACKAGED DEVICES <sup>(1)</sup>		EVALUATION MODULES
	SMALL OUTLINE (DRB)	MSOP PowerPAD™ (DGN)	
-40°C to 85°C	TPA6211A1DRB	TPA6211A1DGN	TPA6211A1EVM

(1) The DGN and DRB are available taped and reeled. To order taped and reeled parts, add the suffix R to the part number (TPA6211A1DGNR or TPA6211A1DRBR).

**Terminal Functions**

TERMINAL NAME	DRB, DGN	I/O	DESCRIPTION
IN-	4	I	Negative differential input
IN+	3	I	Positive differential input
V <sub>DD</sub>	6	I	Power supply
V <sub>O+</sub>	5	O	Positive BTL output
GND	7	I	High-current ground
V <sub>O-</sub>	8	O	Negative BTL output
SHUTDOWN	1	I	Shutdown terminal (active low logic)
BYPASS	2		Mid-supply voltage, adding a bypass capacitor improves PSRR
Thermal Pad	-	-	Connect to ground. Thermal pad must be soldered down in all applications to properly secure device on the PCB.

**ABSOLUTE MAXIMUM RATINGS**

over operating free-air temperature range unless otherwise noted<sup>(1)</sup>

	UNIT	
V <sub>DD</sub> Supply voltage	-0.3 V to 6 V	
V <sub>I</sub> Input voltage	-0.3 V to V <sub>DD</sub> + 0.3 V	
Continuous total power dissipation	See Dissipation Rating Table	
T <sub>A</sub> Operating free-air temperature	-40°C to 85°C	
T <sub>J</sub> Junction temperature	-40°C to 150°C	
T <sub>stg</sub> Storage temperature	-65°C to 85°C	
Lead temperature 1,6 mm (1/16 Inch) from case for 10 seconds	DRB	260°C
	DGN	235°C

(1) Stresses beyond those listed under "absolute maximum ratings" may cause permanent damage to the device. These are stress ratings only, and functional operation of the device at these or any other conditions beyond those indicated under "recommended operating conditions" is not implied. Exposure to absolute-maximum-rated conditions for extended periods may affect device reliability.

**PACKAGE DISSIPATION RATINGS**

PACKAGE	T <sub>A</sub> ≤ 25°C POWER RATING	DERATING FACTOR <sup>(1)</sup>	T <sub>A</sub> = 70°C POWER RATING	T <sub>A</sub> = 85°C POWER RATING
DGN	2.13 W	17.1 mW/°C	1.36 W	1.11 W
DRB	2.7 W	21.8 mW/°C	1.7 W	1.4 W

(1) Derating factor based on high-k board layout.

**RECOMMENDED OPERATION CONDITIONS**

		MIN	TYP	MAX	UNIT
$V_{DD}$	Supply voltage	2.5		5.5	V
$V_{IH}$	High-level input voltage	SHUTDOWN		1.55	V
$V_{IL}$	Low-level input voltage	SHUTDOWN		0.5	V
$T_A$	Operating free-air temperature	-40		85	°C

**ELECTRICAL CHARACTERISTICS**
 $T_A = 25^\circ\text{C}$ 

PARAMETER	TEST CONDITIONS	MIN	TYP	MAX	UNIT
$V_{OS}$	Output offset voltage (measured differentially) $V_I = 0\text{ V differential, Gain} = 1\text{ V/V, } V_{DD} = 5.5\text{ V}$	-9	0.3	9	mV
PSRR	Power supply rejection ratio $V_{DD} = 2.5\text{ V to } 5.5\text{ V}$		-85	-60	dB
$V_{IC}$	Common mode input range $V_{DD} = 2.5\text{ V to } 5.5\text{ V}$	0.5		$V_{DD}-0.8$	V
CMRR	Common mode rejection ratio $V_{DD} = 5.5\text{ V, } V_{IC} = 0.5\text{ V to } 4.7\text{ V}$		-63	-40	dB
	$V_{DD} = 2.5\text{ V, } V_{IC} = 0.5\text{ V to } 1.7\text{ V}$		-63	-40	
Low-output swing	$R_L = 4\ \Omega,$ $V_{IN+} = V_{DD},$ $V_{IN-} = 0\text{ V,}$ Gain = 1 V/V, $V_{IN-} = 0\text{ V or}$ $V_{IN-} = V_{DD}$	$V_{DD} = 5.5\text{ V}$	0.45		V
		$V_{DD} = 3.6\text{ V}$	0.37		
		$V_{DD} = 2.5\text{ V}$	0.26	0.4	
High-output swing	$R_L = 4\ \Omega,$ $V_{IN+} = V_{DD},$ $V_{IN-} = V_{DD}$ Gain = 1 V/V, $V_{IN-} = 0\text{ V or}$ $V_{IN+} = 0\text{ V}$	$V_{DD} = 5.5\text{ V}$	4.95		V
		$V_{DD} = 3.6\text{ V}$	3.18		
		$V_{DD} = 2.5\text{ V}$	2	2.13	
$ I_{IH} $	High-level input current, shutdown $V_{DD} = 5.5\text{ V, } V_I = 5.8\text{ V}$		58	100	$\mu\text{A}$
$ I_{IL} $	Low-level input current, shutdown $V_{DD} = 5.5\text{ V, } V_I = -0.3\text{ V}$		3	100	$\mu\text{A}$
$I_Q$	Quiescent current $V_{DD} = 2.5\text{ V to } 5.5\text{ V, no load}$		4	5	mA
$I_{(SD)}$	Supply current $V(\text{SHUTDOWN}) \leq 0.5\text{ V, } V_{DD} = 2.5\text{ V to } 5.5\text{ V,}$ $R_L = 4\ \Omega$		0.01	1	$\mu\text{A}$
Gain	$R_L = 4\ \Omega$	$\frac{38\text{ k}\Omega}{R_1}$	$\frac{40\text{ k}\Omega}{R_1}$	$\frac{42\text{ k}\Omega}{R_1}$	V/V
Resistance from shutdown to GND			100		k $\Omega$

**OPERATING CHARACTERISTICS**

T<sub>A</sub> = 25°C, Gain = 1 V/V

PARAMETER	TEST CONDITIONS		MIN	TYP	MAX	UNIT
P <sub>O</sub> Output power	THD + N= 1%, f = 1 kHz, R <sub>L</sub> = 3 Ω	V <sub>DD</sub> = 5 V		2.45		W
		V <sub>DD</sub> = 3.6 V		1.22		
		V <sub>DD</sub> = 2.5 V		0.49		
	THD + N= 1%, f = 1 kHz, R <sub>L</sub> = 4 Ω	V <sub>DD</sub> = 5 V		2.22		
		V <sub>DD</sub> = 3.6 V		1.1		
		V <sub>DD</sub> = 2.5 V		0.47		
	THD + N= 1%, f = 1 kHz, R <sub>L</sub> = 8 Ω	V <sub>DD</sub> = 5 V		1.36		
		V <sub>DD</sub> = 3.6 V		0.72		
		V <sub>DD</sub> = 2.5 V		0.33		
THD+N Total harmonic distortion plus noise	f = 1 kHz, R <sub>L</sub> = 3 Ω	P <sub>O</sub> = 2 W	V <sub>DD</sub> = 5 V	0.045%		
		P <sub>O</sub> = 1 W	V <sub>DD</sub> = 3.6 V	0.05%		
		P <sub>O</sub> = 300 mW	V <sub>DD</sub> = 2.5 V	0.06%		
	f = 1 kHz, R <sub>L</sub> = 4 Ω	P <sub>O</sub> = 1.8 W	V <sub>DD</sub> = 5 V	0.03%		
		P <sub>O</sub> = 0.7 W	V <sub>DD</sub> = 3.6 V	0.03%		
		P <sub>O</sub> = 300 mW	V <sub>DD</sub> = 2.5 V	0.04%		
	f = 1 kHz, R <sub>L</sub> = 8 Ω	P <sub>O</sub> = 1 W	V <sub>DD</sub> = 5 V	0.02%		
		P <sub>O</sub> = 0.5 W	V <sub>DD</sub> = 3.6 V	0.02%		
		P <sub>O</sub> = 200 mW	V <sub>DD</sub> = 2.5 V	0.03%		
k <sub>SVR</sub> Supply ripple rejection ratio	V <sub>DD</sub> = 3.6 V, Inputs ac-grounded with C <sub>i</sub> = 2 μF, V <sub>(RIPPLE)</sub> = 200 mV <sub>pp</sub>	f = 217 Hz		-80		dB
		f = 20 Hz to 20 kHz		-70		
SNR Signal-to-noise ratio	V <sub>DD</sub> = 5 V, P <sub>O</sub> = 2 W, R <sub>L</sub> = 4 Ω			105		dB
V <sub>n</sub> Output voltage noise	V <sub>DD</sub> = 3.6 V, f = 20 Hz to 20 kHz, Inputs ac-grounded with C <sub>i</sub> = 2 μF	No weighting		15		μV <sub>RMS</sub>
		A weighting		12		
CMRR Common mode rejection ratio	V <sub>DD</sub> = 3.6 V, V <sub>IC</sub> = 1 V <sub>pp</sub>	f = 217 Hz		-65		dB
Z <sub>I</sub> Input impedance			38	40	44	kΩ
Start-up time from shutdown	V <sub>DD</sub> = 3.6 V, No C <sub>BYPASS</sub>			4		μs
	V <sub>DD</sub> = 3.6 V, C <sub>BYPASS</sub> = 0.1 μF			27		ms

**TYPICAL CHARACTERISTICS**

**Table of Graphs**

			FIGURE
$P_O$	Output power	vs Supply voltage	1
		vs Load resistance	2
$P_D$	Power dissipation	vs Output power	3, 4
		vs Output power	5, 6, 7
THD+N	Total harmonic distortion + noise	vs Frequency	8-12
		vs Common-mode input voltage	13
		vs Frequency	14, 15, 16, 17
$K_{SVR}$	Supply voltage rejection ratio	vs Common-mode input voltage	18
	GSM Power supply rejection	vs Time	19
	GSM Power supply rejection	vs Frequency	20
CMRR	Common-mode rejection ratio	vs Frequency	21
		vs Common-mode input voltage	22
	Closed loop gain/phase	vs Frequency	23
	Open loop gain/phase	vs Frequency	24
$I_{DD}$	Supply current	vs Supply voltage	25
		vs Shutdown voltage	26
	Start-up time	vs Bypass capacitor	27

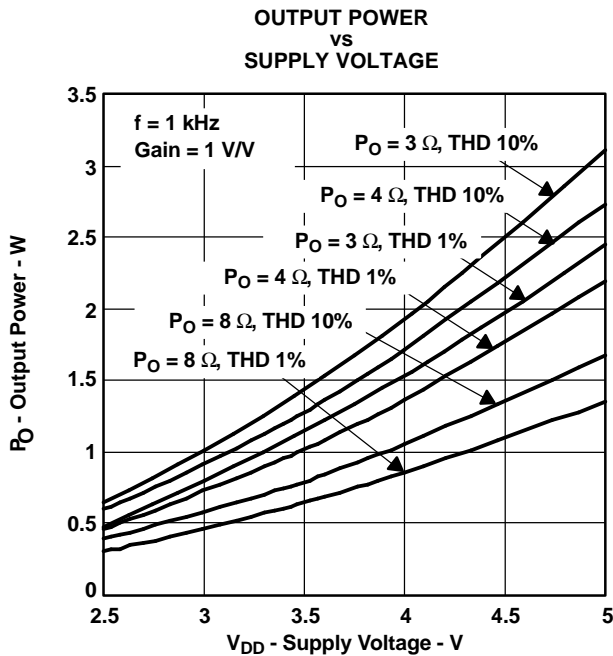

Figure 1.

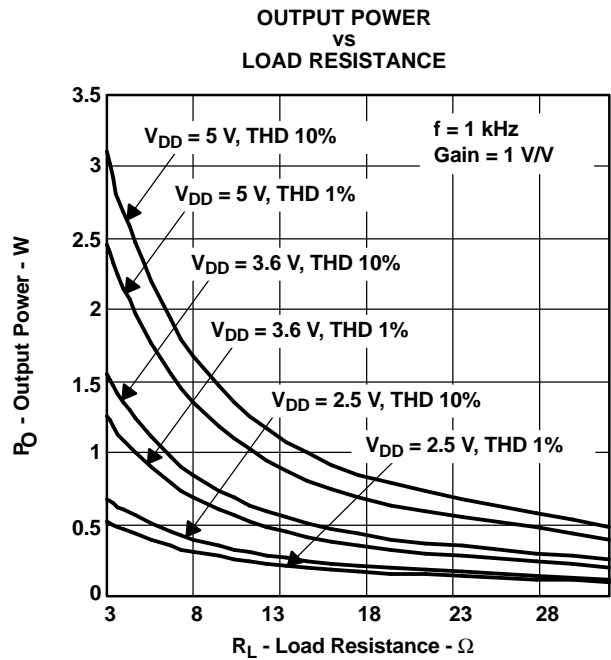

Figure 2.

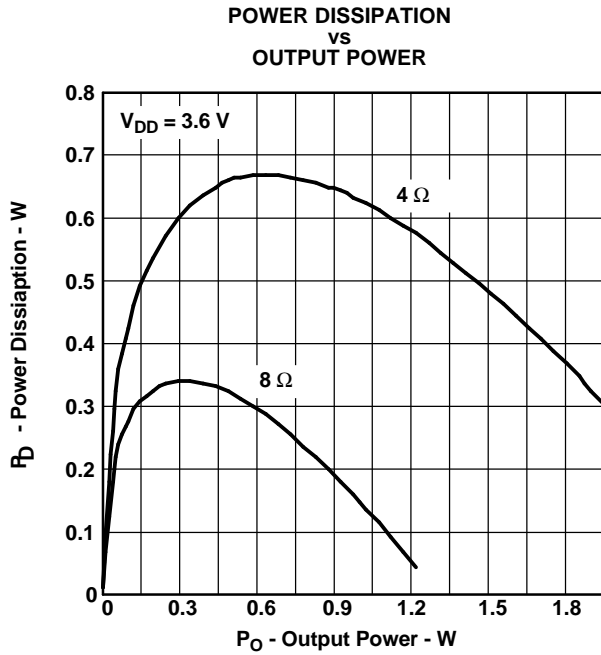

Figure 3.

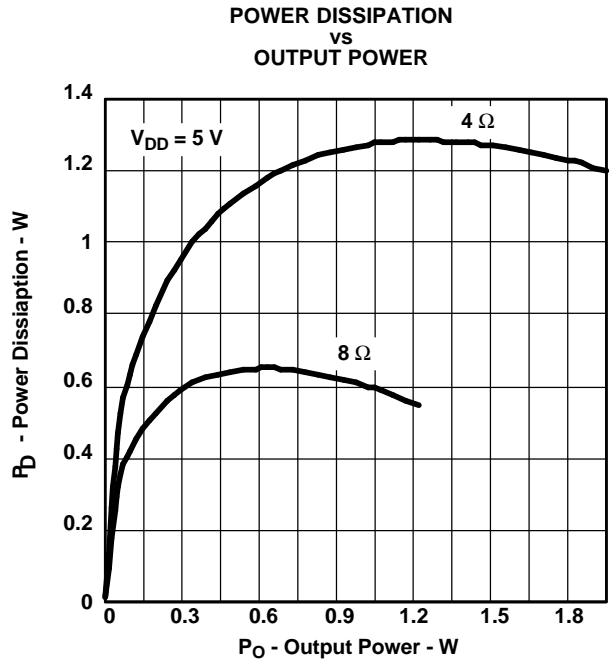

Figure 4.

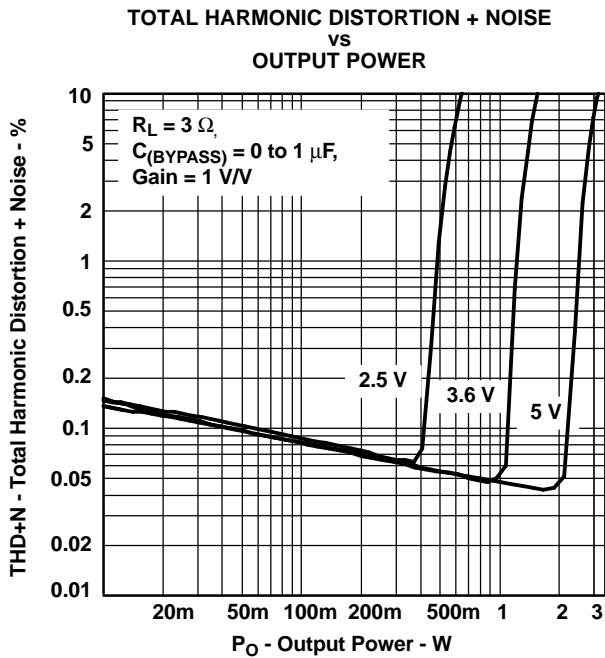

Figure 5.

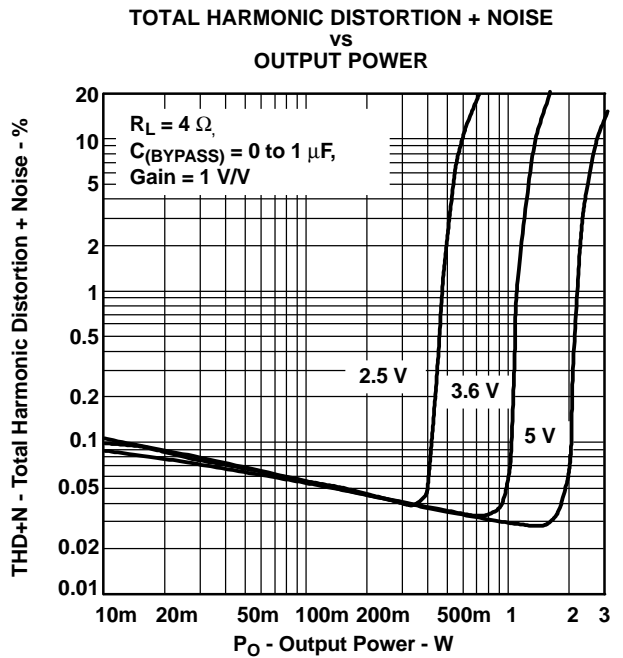

Figure 6.

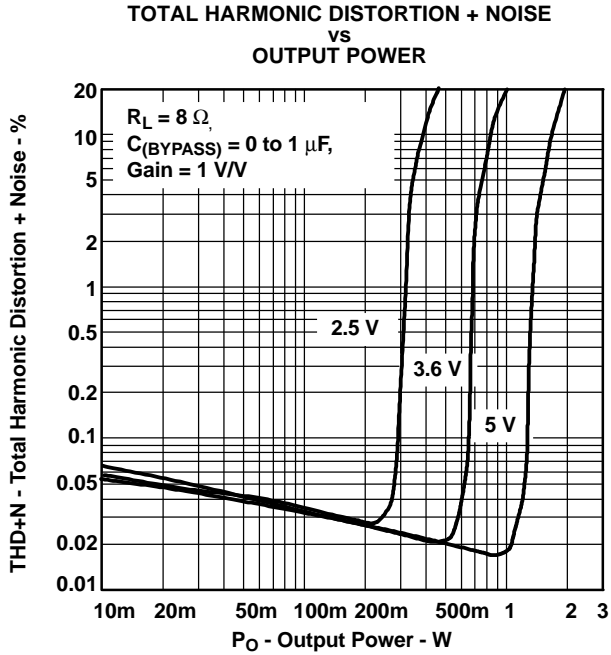

Figure 7.

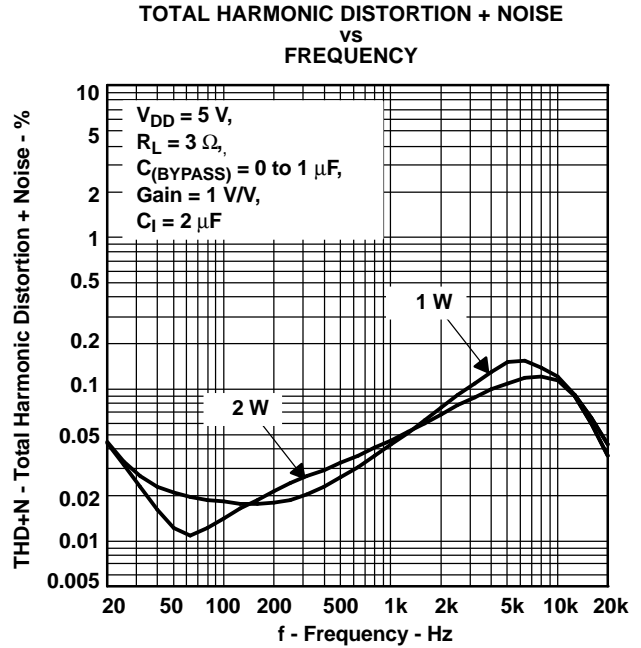

Figure 8.

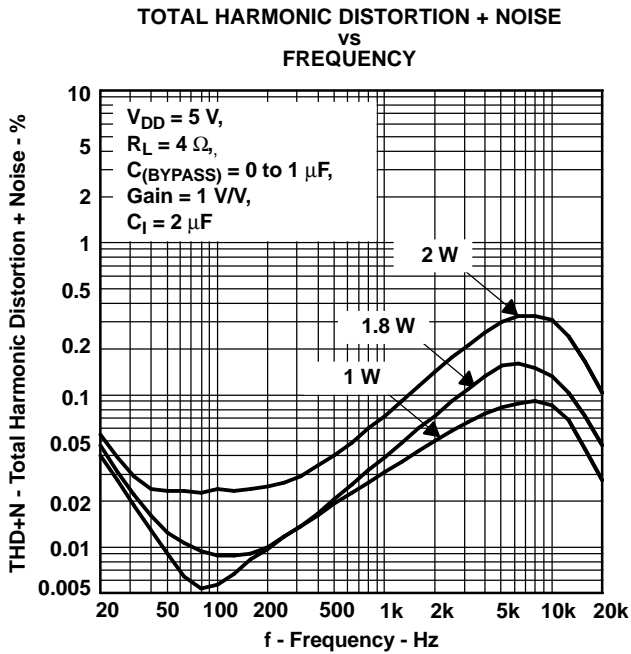

Figure 9.

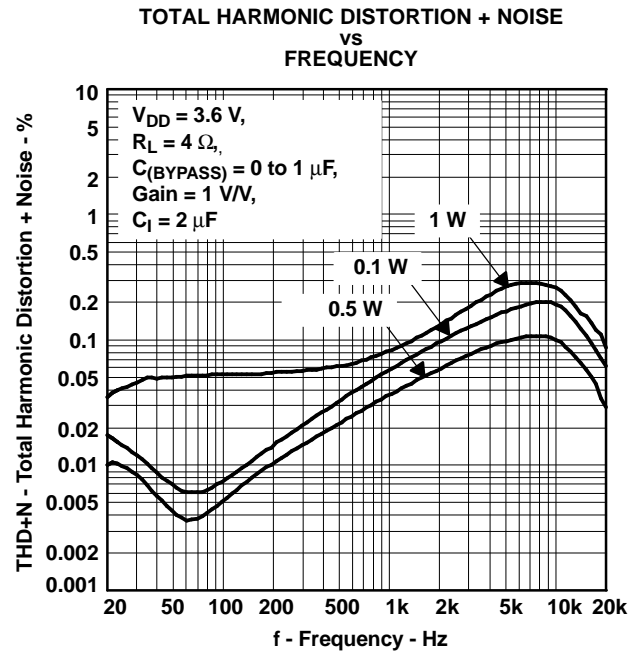

Figure 10.

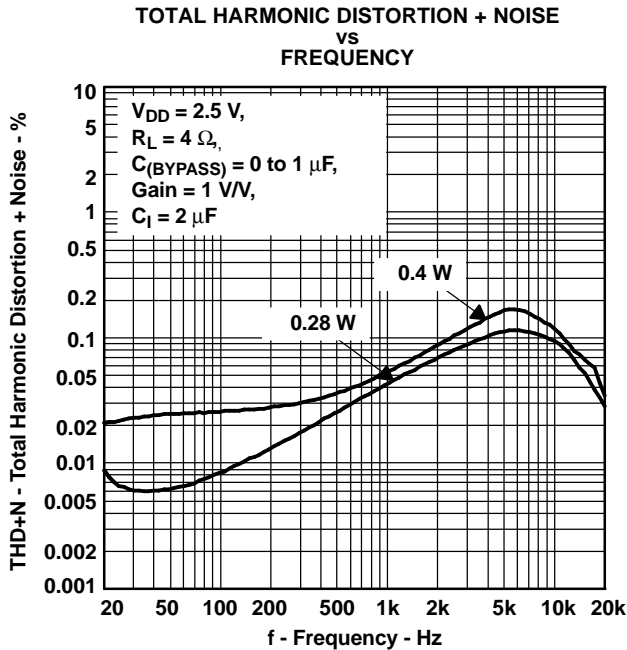

Figure 11.

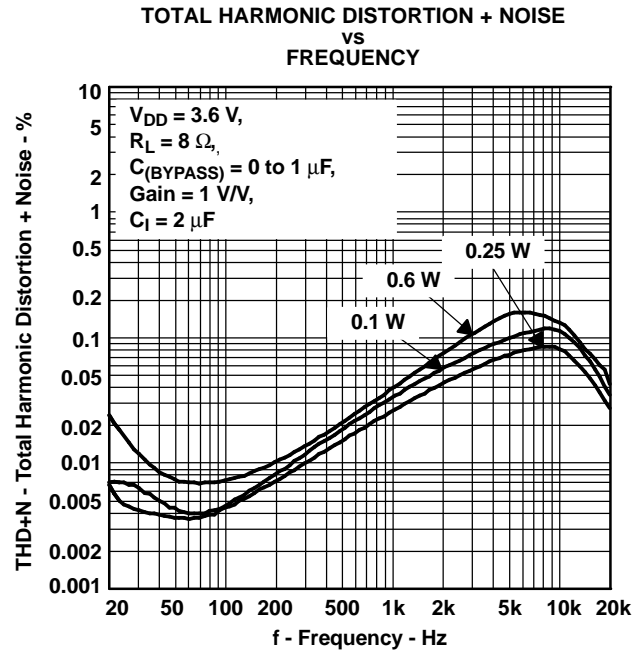

Figure 12.

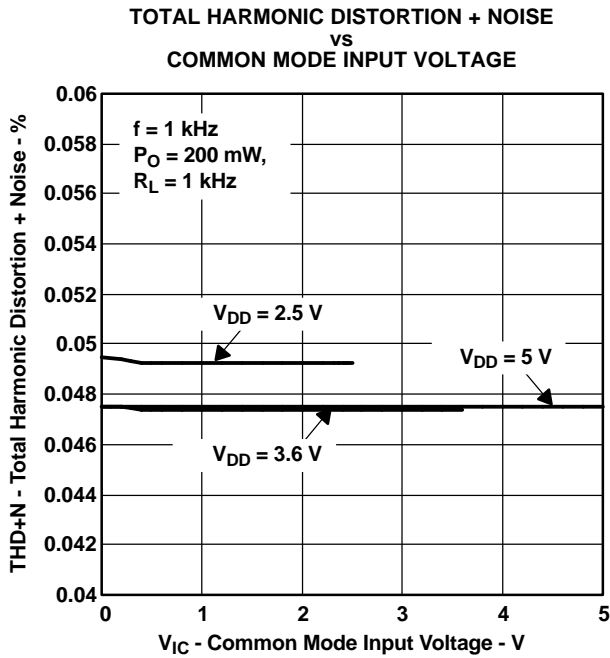

Figure 13.

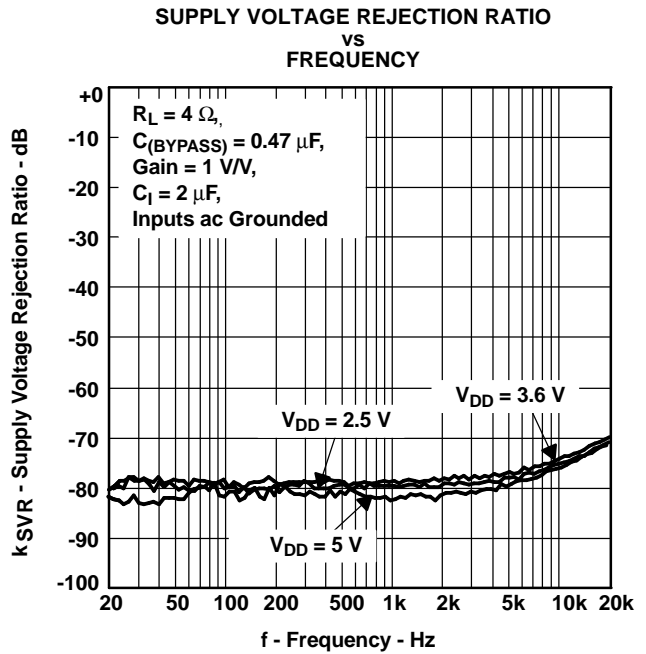

Figure 14.

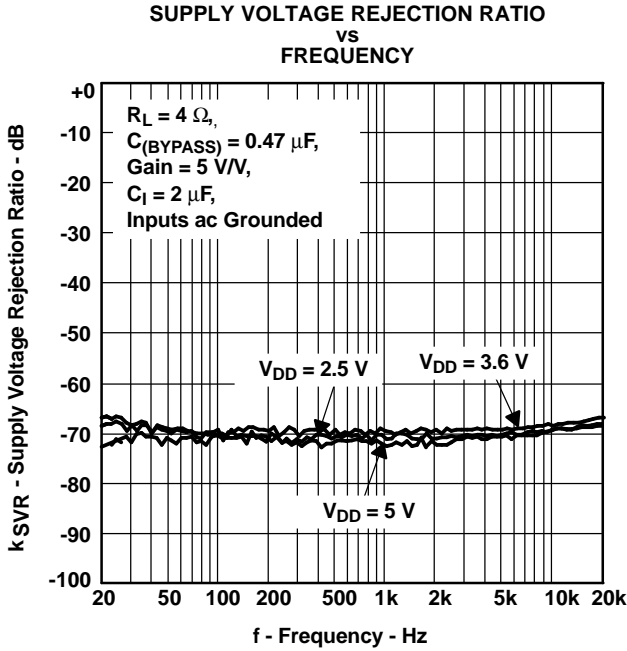

Figure 15.

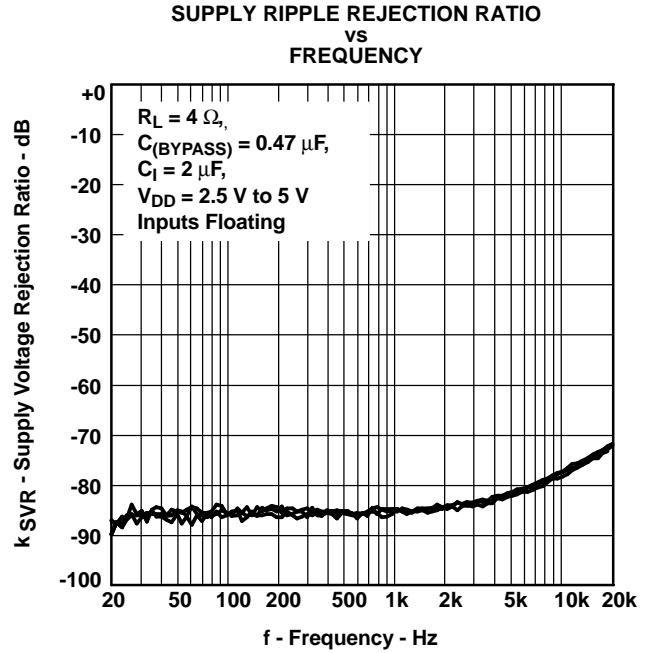

Figure 16.

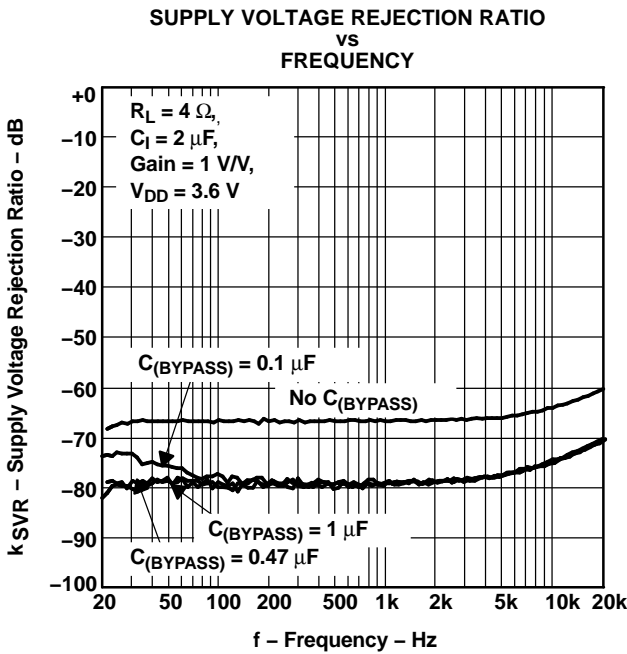

Figure 17.

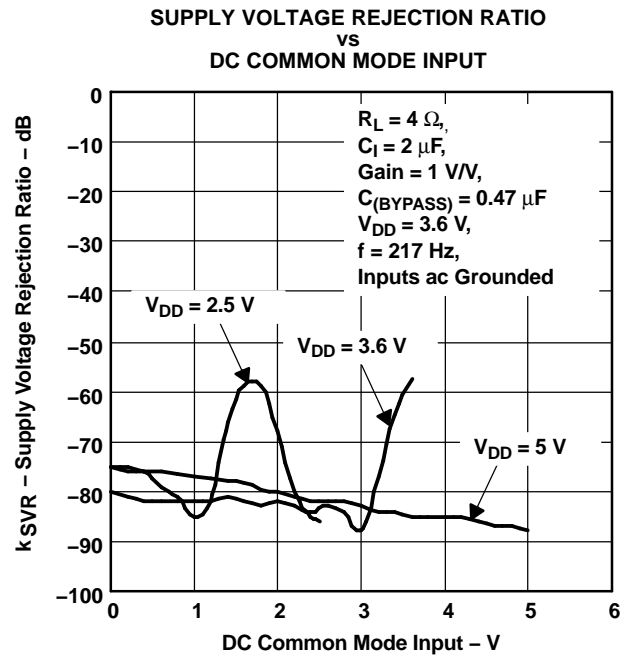

Figure 18.

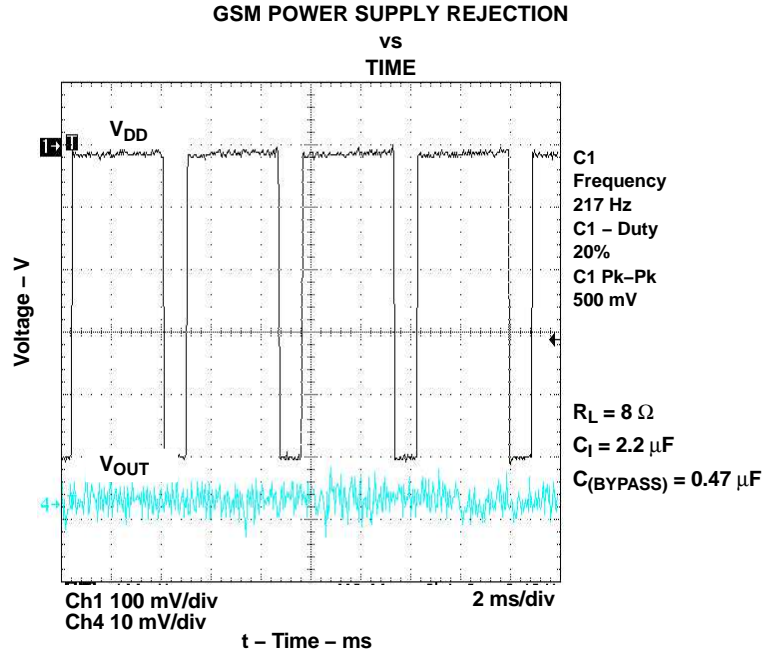

Figure 19.

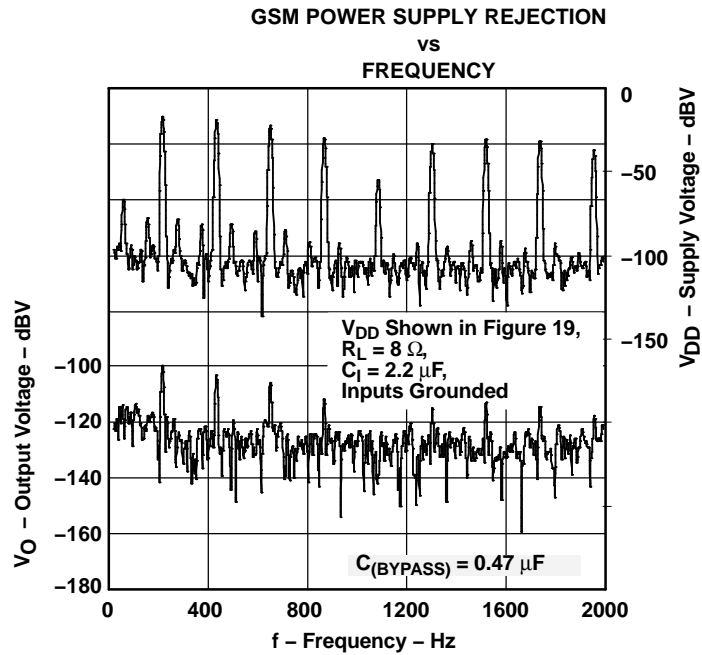

Figure 20.

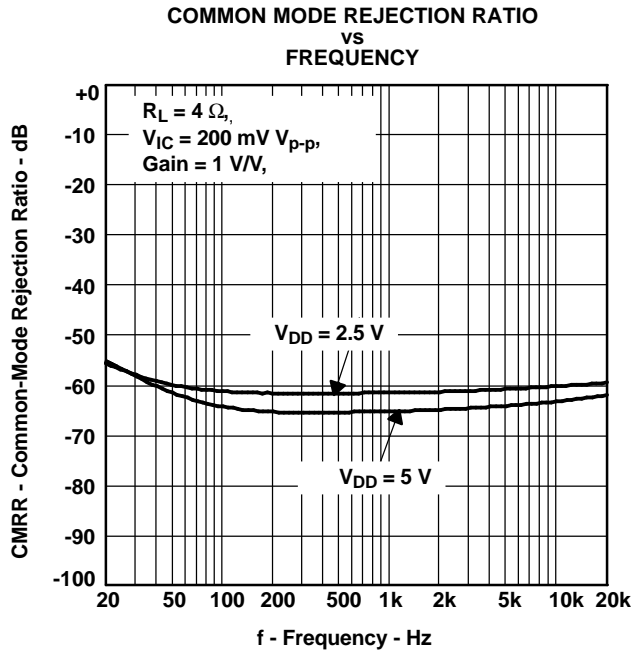

Figure 21.

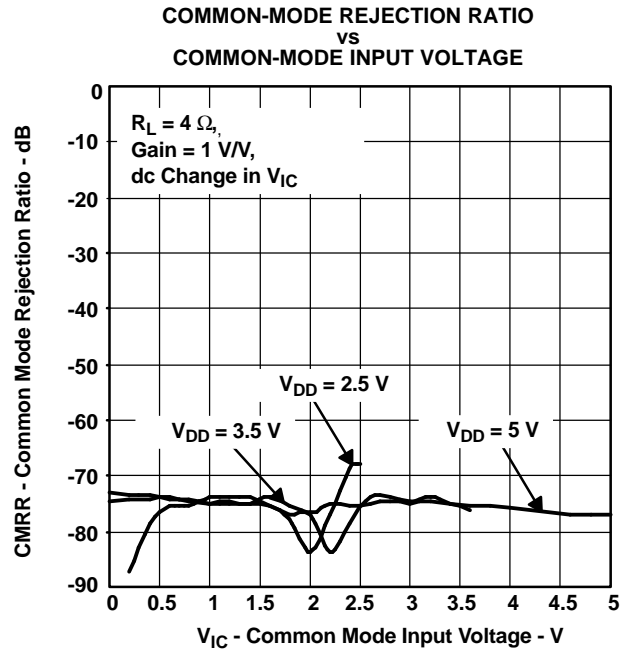

Figure 22.

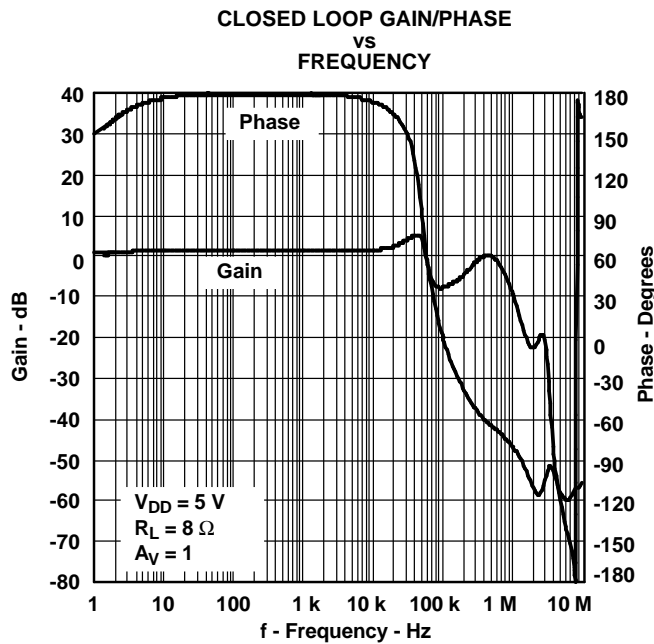

Figure 23.

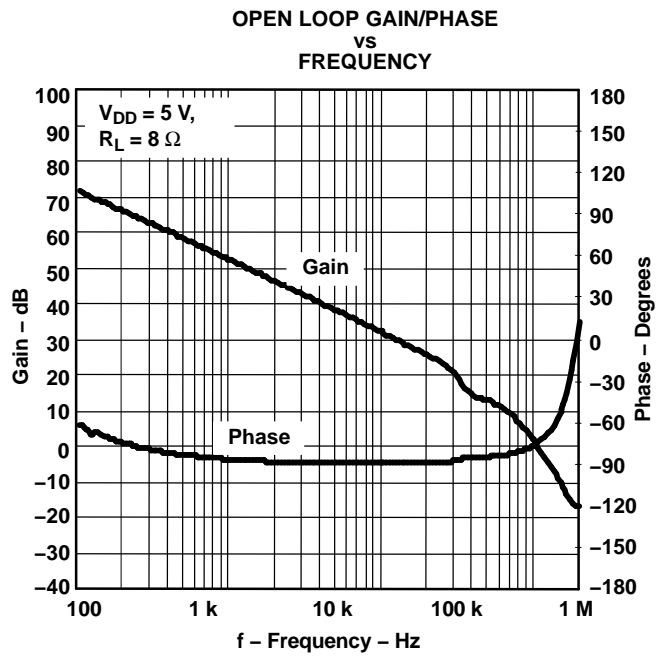

Figure 24.

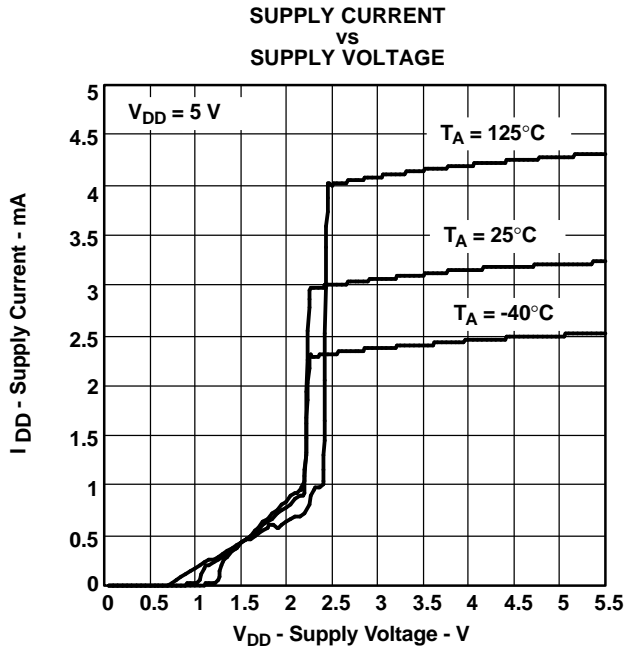

Figure 25.

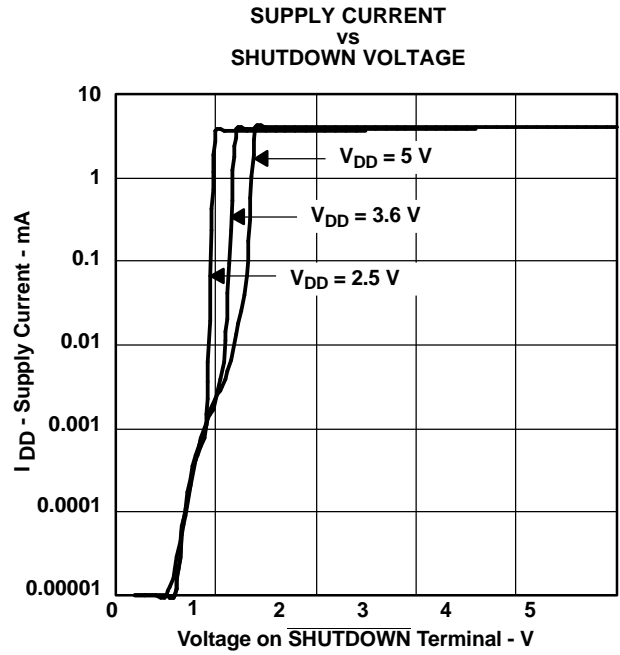

Figure 26.

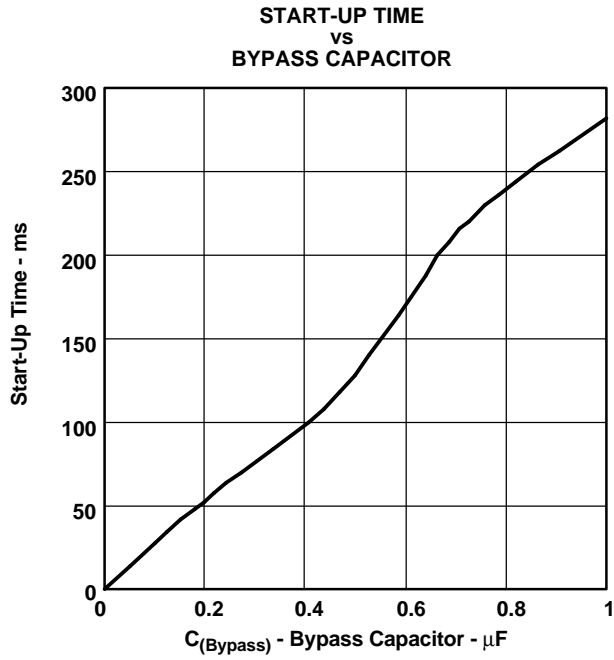

Figure 27.

## APPLICATION INFORMATION

### FULLY DIFFERENTIAL AMPLIFIER

The TPA6211A1 is a fully differential amplifier with differential inputs and outputs. The fully differential amplifier consists of a differential amplifier and a common-mode amplifier. The differential amplifier ensures that the amplifier outputs a differential voltage that is equal to the differential input times the gain. The common-mode feedback ensures that the common-mode voltage at the output is biased around  $V_{DD}/2$  regardless of the common-mode voltage at the input.

#### Advantages of Fully Differential Amplifiers

- Input coupling capacitors not required:** A fully differential amplifier with good CMRR, like the TPA6211A1, allows the inputs to be biased at voltage other than mid-supply. For example, if a DAC has a lower mid-supply voltage than that of the TPA6211A1, the common-mode feedback circuit compensates, and the outputs are still biased at the mid-supply point of the TPA6211A1. The inputs of the TPA6211A1 can be biased from 0.5 V to  $V_{DD} - 0.8$  V. If the inputs are biased outside of that range, input coupling capacitors are required.

- Mid-supply bypass capacitor,  $C_{(BYPASS)}$ , not required:** The fully differential amplifier does not require a bypass capacitor. Any shift in the mid-supply voltage affects both positive and negative channels equally, thus canceling at the differential output. Removing the bypass capacitor slightly worsens power supply rejection ratio ( $K_{SVR}$ ), but a slight decrease of  $K_{SVR}$  may be acceptable when an additional component can be eliminated (See Figure 17).
- Better RF-immunity:** GSM handsets save power by turning on and shutting off the RF transmitter at a rate of 217 Hz. The transmitted signal is picked-up on input and output traces. The fully differential amplifier cancels the signal much better than the typical audio amplifier.

### APPLICATION SCHEMATICS

Figure 28 through Figure 31 show application schematics for differential and single-ended inputs. Typical values are shown in Table 1.

**Table 1. Typical Component Values**

COMPONENT	VALUE
$R_I$	40 k $\Omega$
$C_{(BYPASS)}^{(1)}$	0.22 $\mu$ F
$C_S$	1 $\mu$ F
$C_I$	0.22 $\mu$ F

(1)  $C_{(BYPASS)}$  is optional.

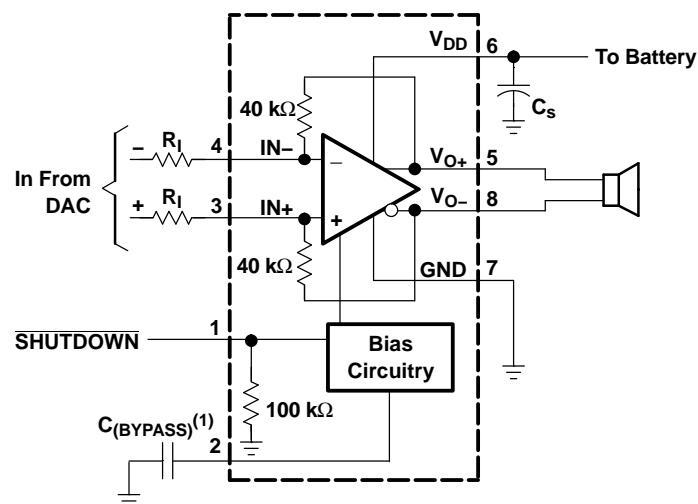

(1)  $C_{(BYPASS)}$  is optional

**Figure 28. Typical Differential Input Application Schematic**

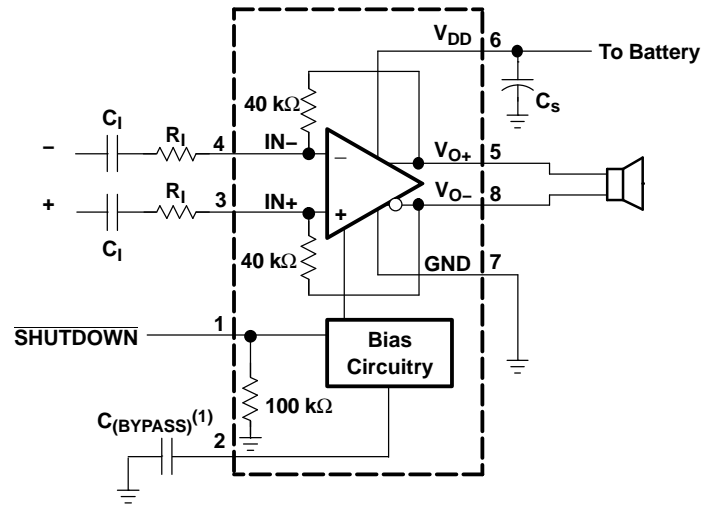

(1)  $C_{(BYPASS)}$  is optional

Figure 29. Differential Input Application Schematic Optimized With Input Capacitors

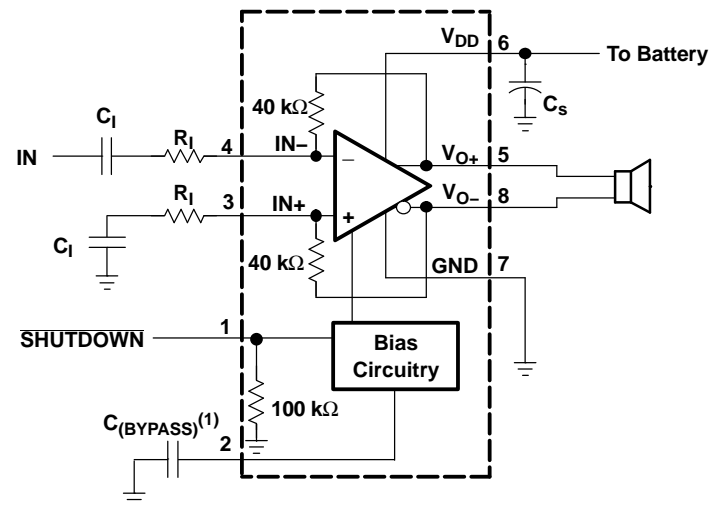

(1)  $C_{(BYPASS)}$  is optional

Figure 30. Single-Ended Input Application Schematic

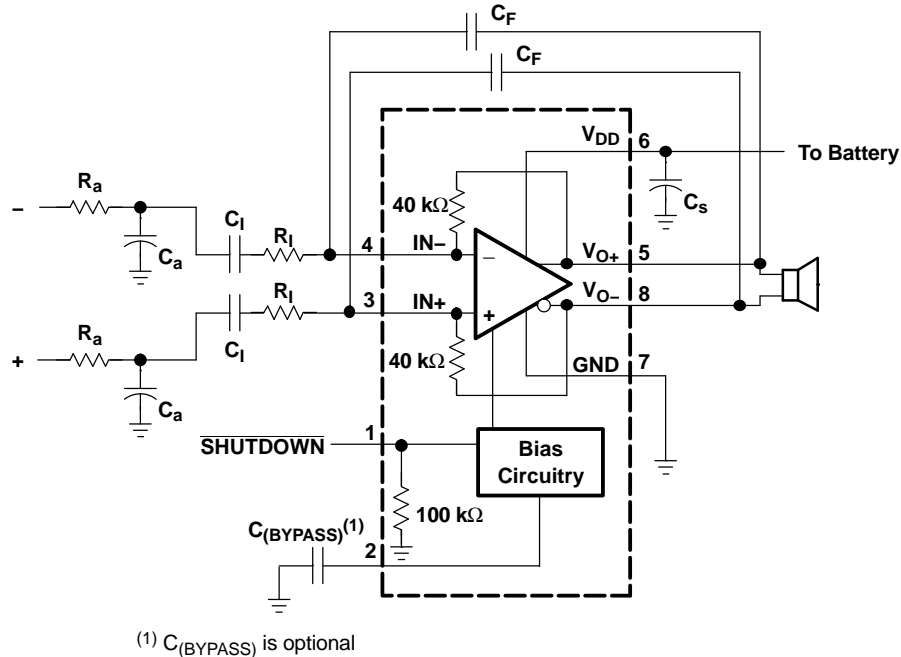

Figure 31. Differential Input Application Schematic With Input Bandpass Filter

## Selecting Components

### Resistors ( $R_l$ )

The input resistor ( $R_l$ ) can be selected to set the gain of the amplifier according to equation 1.

$$\text{Gain} = R_F/R_l \quad (1)$$

The internal feedback resistors ( $R_F$ ) are trimmed to 40 kΩ.

Resistor matching is very important in fully differential amplifiers. The balance of the output on the reference voltage depends on matched ratios of the resistors. CMRR, PSRR, and the cancellation of the second harmonic distortion diminishes if resistor mismatch occurs. Therefore, 1%-tolerance resistors or better are recommended to optimize performance.

### Bypass Capacitor ( $C_{\text{BYPASS}}$ ) and Start-Up Time

The internal voltage divider at the BYPASS pin of this device sets a mid-supply voltage for internal references and sets the output common mode voltage to  $V_{\text{DD}}/2$ . Adding a capacitor filters any noise into this pin, increasing  $k_{\text{SVR}}$ .  $C_{\text{BYPASS}}$  also determines the rise time of  $V_{\text{O+}}$  and  $V_{\text{O-}}$  when the device exits shutdown. The larger the capacitor, the slower the rise time.

### Input Capacitor ( $C_l$ )

The TPA6211A1 does not require input coupling capacitors when driven by a differential input source biased from 0.5 V to  $V_{\text{DD}} - 0.8$  V. Use 1% tolerance or better gain-setting resistors if not using input coupling capacitors.

In the single-ended input application, an input capacitor,  $C_l$ , is required to allow the amplifier to bias the input signal to the proper dc level. In this case,  $C_l$  and  $R_l$  form a high-pass filter with the corner frequency defined in Equation 2.

$$f_c = \frac{1}{2\pi R_l C_l} \quad (2)$$

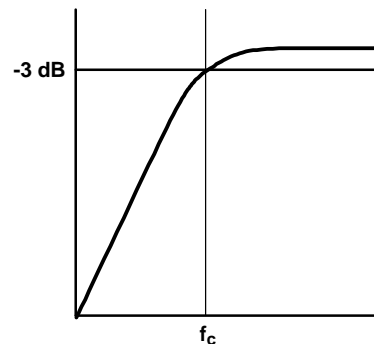

The value of  $C_1$  is an important consideration. It directly affects the bass (low frequency) performance of the circuit. Consider the example where  $R_1$  is 10 k $\Omega$  and the specification calls for a flat bass response down to 100 Hz. Equation 2 is reconfigured as Equation 3.

$$C_1 = \frac{1}{2\pi R_1 f_c} \quad (3)$$

In this example,  $C_1$  is 0.16  $\mu$ F, so the likely choice ranges from 0.22  $\mu$ F to 0.47  $\mu$ F. Ceramic capacitors are preferred because they are the best choice in preventing leakage current. When polarized capacitors are used, the positive side of the capacitor faces the amplifier input in most applications. The input dc level is held at  $V_{DD}/2$ , typically higher than the source dc level. It is important to confirm the capacitor polarity in the application.

**Band-Pass Filter ( $R_a$ ,  $C_a$ , and  $C_a$ )**

It may be desirable to have signal filtering beyond the one-pole high-pass filter formed by the combination of  $C_1$  and  $R_1$ . A low-pass filter may be added by placing a capacitor ( $C_F$ ) between the inputs and outputs, forming a band-pass filter.

An example of when this technique might be used would be in an application where the desirable pass-band range is between 100 Hz and 10 kHz, with a gain of 4 V/V. The following equations illustrate how the proper values of  $C_F$  and  $C_1$  can be determined.

**Step 1: Low-Pass Filter**

$$f_{c(LPF)} = \frac{1}{2\pi R_F C_F}$$

where  $R_F$  is the internal 40 k $\Omega$  resistor

$$f_{c(LPF)} = \frac{1}{2\pi 40 \text{ k}\Omega C_F} \quad (5)$$

Therefore,

$$C_F = \frac{1}{2\pi 40 \text{ k}\Omega f_{c(LPF)}} \quad (6)$$

Substituting 10 kHz for  $f_{c(LPF)}$  and solving for  $C_F$ :

$$C_F = 398 \text{ pF}$$

**Step 2: High-Pass Filter**

$$f_{c(HPF)} = \frac{1}{2\pi R_1 C_1}$$

where  $R_1$  is the input resistor

Since the application in this case requires a gain of 4 V/V,  $R_1$  must be set to 10 k $\Omega$ .

Substituting  $R_1$  into equation 6.

$$f_{c(HPF)} = \frac{1}{2\pi 10 \text{ k}\Omega C_1} \quad (8)$$

Therefore,

$$C_1 = \frac{1}{2\pi 10 \text{ k}\Omega f_{c(HPF)}} \quad (9)$$

Substituting 100 Hz for  $f_{c(HPF)}$  and solving for  $C_1$ :

$$C_1 = 0.16 \mu\text{F}$$

At this point, a first-order band-pass filter has been created with the low-frequency cutoff set to 100 Hz and the high-frequency cutoff set to 10 kHz.

The process can be taken a step further by creating a second-order high-pass filter. This is accomplished by placing a resistor ( $R_a$ ) and capacitor ( $C_a$ ) in the input path. It is important to note that  $R_a$  must be at least 10 times smaller than  $R_1$ ; otherwise its value has a noticeable effect on the gain, as  $R_a$  and  $R_1$  are in series.

**Step 3: Additional Low-Pass Filter**

$R_a$  must be at least 10x smaller than  $R_1$ , Set  $R_a = 1 \text{ k}\Omega$

$$f_{c(LPF)} = \frac{1}{2\pi R_a C_a} \quad (10)$$

Therefore,

$$C_a = \frac{1}{2\pi 1 \text{ k}\Omega f_{c(LPF)}} \quad (11)$$

Substituting 10 kHz for  $f_{c(LPF)}$  and solving for  $C_a$ :

$$C_a = 160 \text{ pF}$$

Figure 32 is a bode plot for the band-pass filter in the previous example. Figure 31 shows how to configure the TPA6211A1 as a band-pass filter.

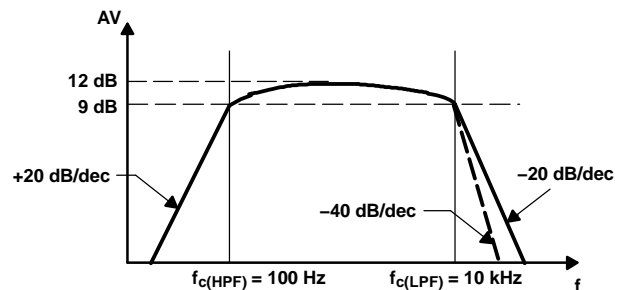

Figure 32. Bode Plot

### Decoupling Capacitor ( $C_S$ )

The TPA6211A1 is a high-performance CMOS audio amplifier that requires adequate power supply decoupling to ensure the output total harmonic distortion (THD) is as low as possible. Power-supply decoupling also prevents oscillations for long lead lengths between the amplifier and the speaker. For higher frequency transients, spikes, or digital hash on the line, a good low equivalent-series-resistance (ESR) ceramic capacitor, typically 0.1  $\mu\text{F}$  to 1  $\mu\text{F}$ , placed as close as possible to the device  $V_{DD}$  lead works best. For filtering lower frequency noise signals, a 10- $\mu\text{F}$  or greater capacitor placed near the audio power amplifier also helps, but is not required in most applications because of the high PSRR of this device.

### USING LOW-ESR CAPACITORS

Low-ESR capacitors are recommended throughout this applications section. A real (as opposed to ideal) capacitor can be modeled simply as a resistor in series with an ideal capacitor. The voltage drop across this resistor minimizes the beneficial effects of the capacitor in the circuit. The lower the equivalent value of this resistance the more the real capacitor behaves like an ideal capacitor.

### DIFFERENTIAL OUTPUT VERSUS SINGLE-ENDED OUTPUT

Figure 33 shows a Class-AB audio power amplifier (APA) in a fully differential configuration. The TPA6211A1 amplifier has differential outputs driving both ends of the load. One of several potential benefits to this configuration is power to the load. The differential drive to the speaker means that as one side is slewing up, the other side is slewing down, and vice versa. This in effect doubles the voltage swing on the load as compared to a ground-referenced load. Plugging  $2 \times V_{O(PP)}$  into the power equation, where voltage is squared, yields 4 $\times$  the output power from the same supply rail and load impedance Equation 12.

$$V_{(rms)} = \frac{V_{O(PP)}}{2\sqrt{2}}$$

$$\text{Power} = \frac{V_{(rms)}^2}{R_L} \quad (12)$$

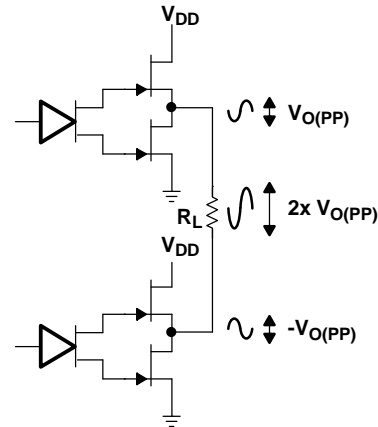

**Figure 33. Differential Output Configuration**

In a typical wireless handset operating at 3.6 V, bridging raises the power into an 8- $\Omega$  speaker from a singled-ended (SE, ground reference) limit of 200 mW to 800 mW. This is a 6-dB improvement in sound power—loudness that can be heard. In addition to increased power, there are frequency-response concerns. Consider the single-supply SE configuration shown in Figure 34. A coupling capacitor ( $C_C$ ) is required to block the dc-offset voltage from the load. This capacitor can be quite large (approximately 33  $\mu\text{F}$  to 1000  $\mu\text{F}$ ) so it tends to be expensive, heavy, occupy valuable PCB area, and have the additional drawback of limiting low-frequency performance. This frequency-limiting effect is due to the high-pass filter network created with the speaker impedance and the coupling capacitance. This is calculated with Equation 13.

$$f_c = \frac{1}{2\pi R_L C_C} \quad (13)$$

For example, a 68- $\mu\text{F}$  capacitor with an 8- $\Omega$  speaker would attenuate low frequencies below 293 Hz. The BTL configuration cancels the dc offsets, which eliminates the need for the blocking capacitors. Low-frequency performance is then limited only by the input network and speaker response. Cost and PCB space are also minimized by eliminating the bulky coupling capacitor.

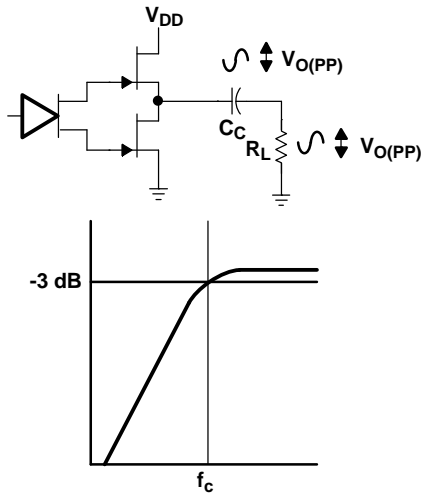

Figure 34. Single-Ended Output and Frequency Response

Increasing power to the load does carry a penalty of increased internal power dissipation. The increased dissipation is understandable considering that the BTL configuration produces 4× the output power of the SE configuration.

### FULLY DIFFERENTIAL AMPLIFIER EFFICIENCY AND THERMAL INFORMATION

Class-AB amplifiers are inefficient, primarily because of voltage drop across the output-stage transistors. The two components of this internal voltage drop are the headroom or dc voltage drop that varies inversely to output power, and the sinewave nature of the output. The total voltage drop can be calculated by subtracting the RMS value of the output voltage from  $V_{DD}$ . The internal voltage drop multiplied by the average value of the supply current,  $I_{DD(avg)}$ , determines the internal power dissipation of the amplifier.

An easy-to-use equation to calculate efficiency starts out as being equal to the ratio of power from the power supply to the power delivered to the load. To accurately calculate the RMS and average values of power in the load and in the amplifier, the current and voltage waveform shapes must first be understood (see Figure 35).

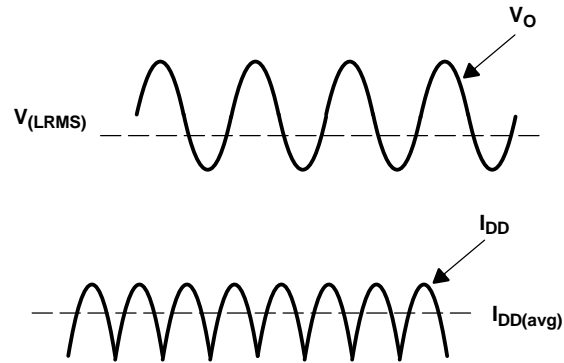

Figure 35. Voltage and Current Waveforms for BTL Amplifiers

Although the voltages and currents for SE and BTL are sinusoidal in the load, currents from the supply are different between SE and BTL configurations. In an SE application the current waveform is a half-wave rectified shape, whereas in BTL it is a full-wave rectified waveform. This means RMS conversion factors are different. Keep in mind that for most of the waveform both the push and pull transistors are not on at the same time, which supports the fact that each amplifier in the BTL device only draws current from the supply for half the waveform. The following equations are the basis for calculating amplifier efficiency.

$$\text{Efficiency of a BTL amplifier} = \frac{P_L}{P_{SUP}}$$

Where:

$$P_L = \frac{V_{Lrms}^2}{R_L}, \text{ and } V_{LRMS} = \frac{V_P}{\sqrt{2}}, \text{ therefore, } P_L = \frac{V_P^2}{2R_L}$$

$$\text{and } P_{SUP} = V_{DD} I_{DDavg} \text{ and } I_{DDavg} = \frac{1}{\pi} \int_0^\pi \frac{V_P}{R_L} \sin(t) dt = -\frac{1}{\pi} \times \frac{V_P}{R_L} [\cos(t)]_0^\pi = \frac{2V_P}{\pi R_L}$$

Therefore,

$$P_{SUP} = \frac{2 V_{DD} V_P}{\pi R_L}$$

substituting  $P_L$  and  $P_{SUP}$  into equation 6,

$$\text{Efficiency of a BTL amplifier} = \frac{\frac{V_P^2}{2R_L}}{\frac{2V_{DD}V_P}{\pi R_L}} = \frac{\pi V_P}{4V_{DD}}$$

Where:

$$V_P = \sqrt{2 P_L R_L}$$

$P_L$  = Power delivered to load  
 $P_{SUP}$  = Power drawn from power supply  
 $V_{LRMS}$  = RMS voltage on BTL load  
 $R_L$  = Load resistance  
 $V_P$  = Peak voltage on BTL load  
 $I_{DDavg}$  = Average current drawn from the power supply  
 $V_{DD}$  = Power supply voltage  
 $\eta_{BTL}$  = Efficiency of a BTL amplifier

(14)

Therefore,

$$\eta_{BTL} = \frac{\pi \sqrt{2 P_L R_L}}{4 V_{DD}}$$

(15)

**Table 2. Efficiency and Maximum Ambient Temperature vs Output Power**

Output Power (W)	Efficiency (%)	Internal Dissipation (W)	Power From Supply (W)	Max Ambient Temperature <sup>(1)</sup> (°C)
<b>5-V, 3-Ω Systems</b>				
0.5	27.2	1.34	1.84	85 <sup>(2)</sup>
1	38.4	1.60	2.60	76
2.45	60.2	1.62	4.07	75
3.1	67.7	1.48	4.58	82
<b>5-V, 4-Ω BTL Systems</b>				
0.5	31.4	1.09	1.59	85 <sup>(2)</sup>
1	44.4	1.25	2.25	85 <sup>(2)</sup>
2	62.8	1.18	3.18	85 <sup>(2)</sup>
2.8	74.3	0.97	3.77	85 <sup>(2)</sup>
<b>5-V, 8-Ω Systems</b>				
0.5	44.4	0.625	1.13	85 <sup>(2)</sup>
1	62.8	0.592	1.60	85 <sup>(2)</sup>
1.36	73.3	0.496	1.86	85 <sup>(2)</sup>
1.7	81.9	0.375	2.08	85 <sup>(2)</sup>

(1) DRB package

(2) Package limited to 85°C ambient

Table 2 employs Equation 15 to calculate efficiencies for four different output power levels. Note that the efficiency of the amplifier is quite low for lower power levels and rises sharply as power to the load is increased resulting in a nearly flat internal power dissipation over the normal operating range. Note that the internal dissipation at full output power is less than in the half power range. Calculating the efficiency for a specific system is the key to proper power supply design. For a 2.8-W audio system with 4-Ω loads and a 5-V supply, the maximum draw on the power supply is almost 3.8 W.

A final point to remember about Class-AB amplifiers is how to manipulate the terms in the efficiency equation to the utmost advantage when possible. Note that in Equation 15,  $V_{DD}$  is in the denominator. This indicates that as  $V_{DD}$  goes down, efficiency goes up.

A simple formula for calculating the maximum power dissipated,  $P_{Dmax}$ , may be used for a differential output application:

$$P_{Dmax} = \frac{2V_{DD}^2}{\pi^2 R_L} \quad (16)$$

$P_{Dmax}$  for a 5-V, 4-Ω system is 1.27 W.

The maximum ambient temperature depends on the heat sinking ability of the PCB system. The derating factor for the 3 mm x 3 mm DRB package is shown in the dissipation rating table. Converting this to  $\theta_{JA}$ :

$$\theta_{JA} = \frac{1}{\text{Derating Factor}} = \frac{1}{0.0218} = 45.9^\circ\text{C/W} \quad (17)$$

Given  $\theta_{JA}$ , the maximum allowable junction temperature, and the maximum internal dissipation, the maximum ambient temperature can be calculated with Equation 18. The maximum recommended junction temperature for the TPA6211A1 is 150°C.

$$\begin{aligned} T_{A \text{ Max}} &= T_{J \text{ Max}} - \theta_{JA} P_{Dmax} \\ &= 150 - 45.9(1.27) = 91.7^\circ\text{C} \end{aligned} \quad (18)$$

Equation 18 shows that the maximum ambient temperature is 91.7°C (package limited to 85°C ambient) at maximum power dissipation with a 5-V supply.

Table 2 shows that for most applications no airflow is required to keep junction temperatures in the specified range. The TPA6211A1 is designed with thermal protection that turns the device off when the junction temperature surpasses 150°C to prevent damage to the IC. In addition, using speakers with an impedance higher than 4-Ω dramatically increases the thermal performance by reducing the output current.

## PCB LAYOUT

Use the following land pattern for board layout with the 8-pin QFN (DRB) package. Note that the solder paste should use a hatch pattern to fill solder paste at 50% to ensure that there is not too much solder paste under the package.

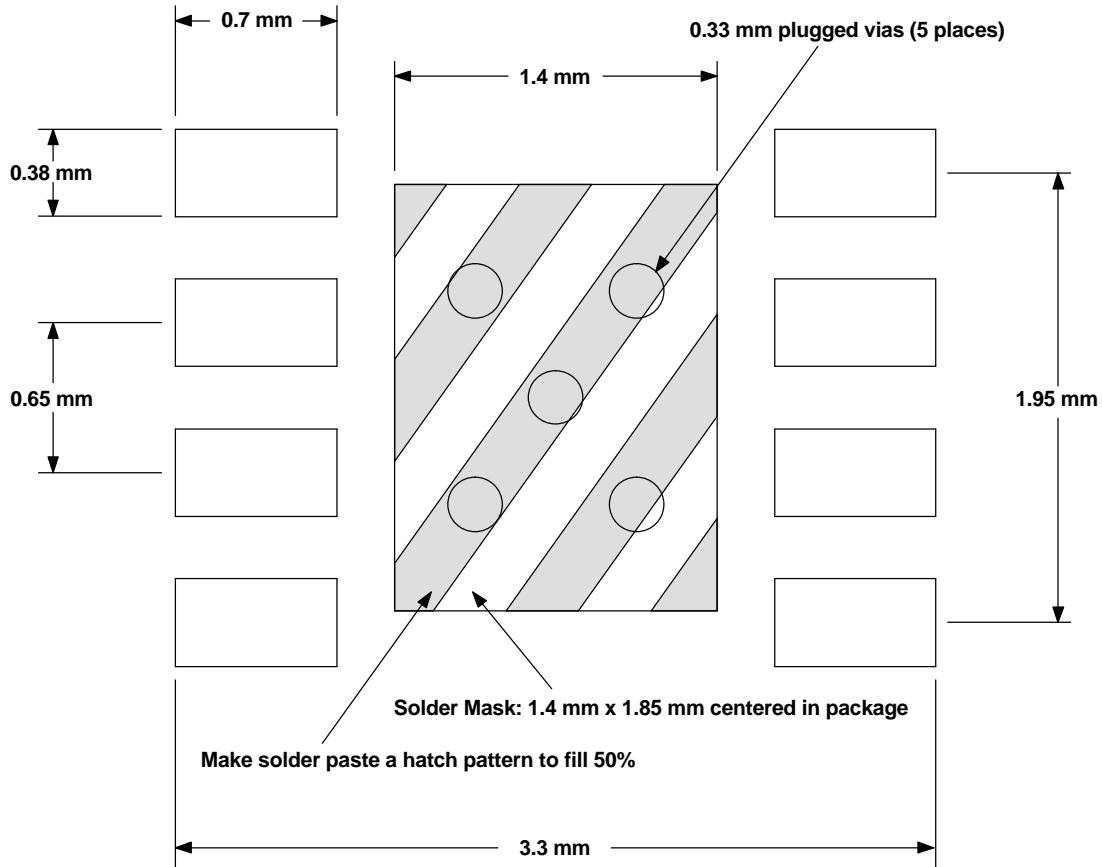

Figure 36. TPA6211A1 8-Pin QFN (DRB) Board Layout (Top View)

**PACKAGING INFORMATION**

Orderable Device	Status <sup>(1)</sup>	Package Type	Package Drawing	Pins	Package Qty	Eco Plan <sup>(2)</sup>	Lead/Ball Finish	MSL Peak Temp <sup>(3)</sup>
TPA6211A1DGN	ACTIVE	MSOP-Power PAD	DGN	8	80	Green (RoHS & no Sb/Br)	CU NIPDAU	Level-1-260C-UNLIM
TPA6211A1DGNG4	ACTIVE	MSOP-Power PAD	DGN	8	80	Green (RoHS & no Sb/Br)	CU NIPDAU	Level-1-260C-UNLIM
TPA6211A1DGNR	ACTIVE	MSOP-Power PAD	DGN	8	2500	Green (RoHS & no Sb/Br)	CU NIPDAU	Level-1-260C-UNLIM
TPA6211A1DGNRG4	ACTIVE	MSOP-Power PAD	DGN	8	2500	Green (RoHS & no Sb/Br)	CU NIPDAU	Level-1-260C-UNLIM
TPA6211A1DRB	ACTIVE	SON	DRB	8	121	Green (RoHS & no Sb/Br)	CU NIPDAU	Level-2-260C-1 YEAR
TPA6211A1DRBG4	ACTIVE	SON	DRB	8	121	Green (RoHS & no Sb/Br)	CU NIPDAU	Level-2-260C-1 YEAR
TPA6211A1DRBR	ACTIVE	SON	DRB	8	3000	Green (RoHS & no Sb/Br)	CU NIPDAU	Level-2-260C-1 YEAR
TPA6211A1DRBRG4	ACTIVE	SON	DRB	8	3000	Green (RoHS & no Sb/Br)	CU NIPDAU	Level-2-260C-1 YEAR

<sup>(1)</sup> The marketing status values are defined as follows:

**ACTIVE:** Product device recommended for new designs.

**LIFEBUY:** TI has announced that the device will be discontinued, and a lifetime-buy period is in effect.

**NRND:** Not recommended for new designs. Device is in production to support existing customers, but TI does not recommend using this part in a new design.

**PREVIEW:** Device has been announced but is not in production. Samples may or may not be available.

**OBSELETE:** TI has discontinued the production of the device.

<sup>(2)</sup> Eco Plan - The planned eco-friendly classification: Pb-Free (RoHS), Pb-Free (RoHS Exempt), or Green (RoHS & no Sb/Br) - please check <http://www.ti.com/productcontent> for the latest availability information and additional product content details.

**TBD:** The Pb-Free/Green conversion plan has not been defined.

**Pb-Free (RoHS):** TI's terms "Lead-Free" or "Pb-Free" mean semiconductor products that are compatible with the current RoHS requirements for all 6 substances, including the requirement that lead not exceed 0.1% by weight in homogeneous materials. Where designed to be soldered at high temperatures, TI Pb-Free products are suitable for use in specified lead-free processes.

**Pb-Free (RoHS Exempt):** This component has a RoHS exemption for either 1) lead-based flip-chip solder bumps used between the die and package, or 2) lead-based die adhesive used between the die and leadframe. The component is otherwise considered Pb-Free (RoHS compatible) as defined above.

**Green (RoHS & no Sb/Br):** TI defines "Green" to mean Pb-Free (RoHS compatible), and free of Bromine (Br) and Antimony (Sb) based flame retardants (Br or Sb do not exceed 0.1% by weight in homogeneous material)

<sup>(3)</sup> MSL, Peak Temp. -- The Moisture Sensitivity Level rating according to the JEDEC industry standard classifications, and peak solder temperature.

**Important Information and Disclaimer:**The information provided on this page represents TI's knowledge and belief as of the date that it is provided. TI bases its knowledge and belief on information provided by third parties, and makes no representation or warranty as to the accuracy of such information. Efforts are underway to better integrate information from third parties. TI has taken and continues to take reasonable steps to provide representative and accurate information but may not have conducted destructive testing or chemical analysis on incoming materials and chemicals. TI and TI suppliers consider certain information to be proprietary, and thus CAS numbers and other limited information may not be available for release.

In no event shall TI's liability arising out of such information exceed the total purchase price of the TI part(s) at issue in this document sold by TI to Customer on an annual basis.

DGN (S-PDSO-G8)

PowerPAD™ PLASTIC SMALL-OUTLINE PACKAGE

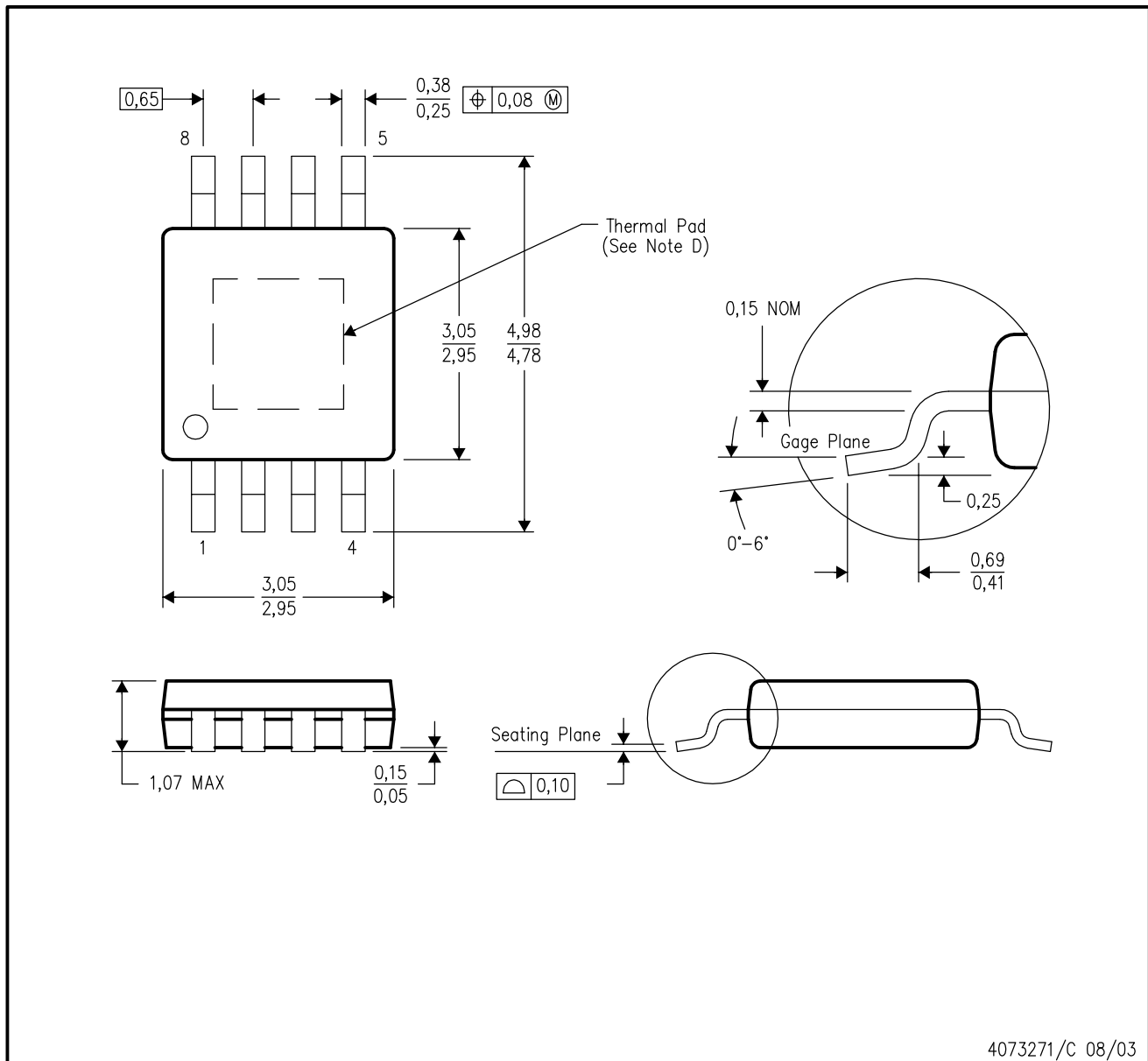

- NOTES:
- A. All linear dimensions are in millimeters.
  - B. This drawing is subject to change without notice.
  - C. Body dimensions do not include mold flash or protrusion.
  - D. This package is designed to be soldered to a thermal pad on the board. Refer to Technical Brief, PowerPad Thermally Enhanced Package, Texas Instruments Literature No. SLMA002 for information regarding recommended board layout. This document is available at [www.ti.com](http://www.ti.com) <<http://www.ti.com>>.
  - E. Falls within JEDEC MO-187

PowerPAD is a trademark of Texas Instruments.

THERMAL INFORMATION

This PowerPAD™ package incorporates an exposed thermal pad that is designed to be attached directly to an external heatsink. When the thermal pad is soldered directly to the printed circuit board (PCB), the PCB can be used as a heatsink. In addition, through the use of thermal vias, the thermal pad can be attached directly to a ground or power plane (whichever is applicable), or alternatively, a special heatsink structure designed into the PCB. This design optimizes the heat transfer from the integrated circuit (IC).

For additional information on the PowerPAD package and how to take advantage of its heat dissipating abilities, refer to Technical Brief, PowerPAD Thermally Enhanced Package, Texas Instruments Literature No. SLMA002 and Application Brief, PowerPAD Made Easy, Texas Instruments Literature No. SLMA004. Both documents are available at [www.ti.com](http://www.ti.com).

The exposed thermal pad dimensions for this package are shown in the following illustration.

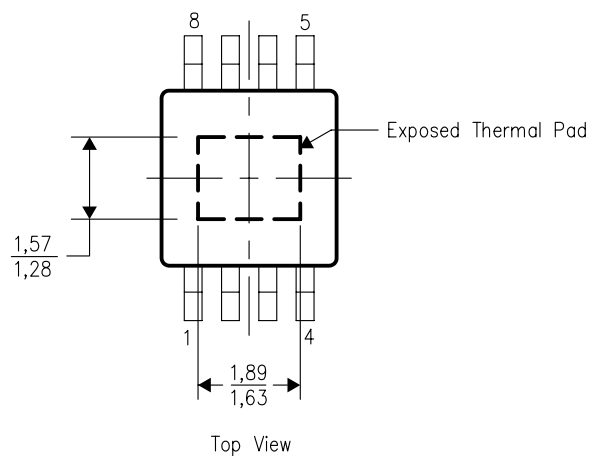

NOTE: All linear dimensions are in millimeters

Exposed Thermal Pad Dimensions

DGN (R-PDS0-G8) PowerPAD™

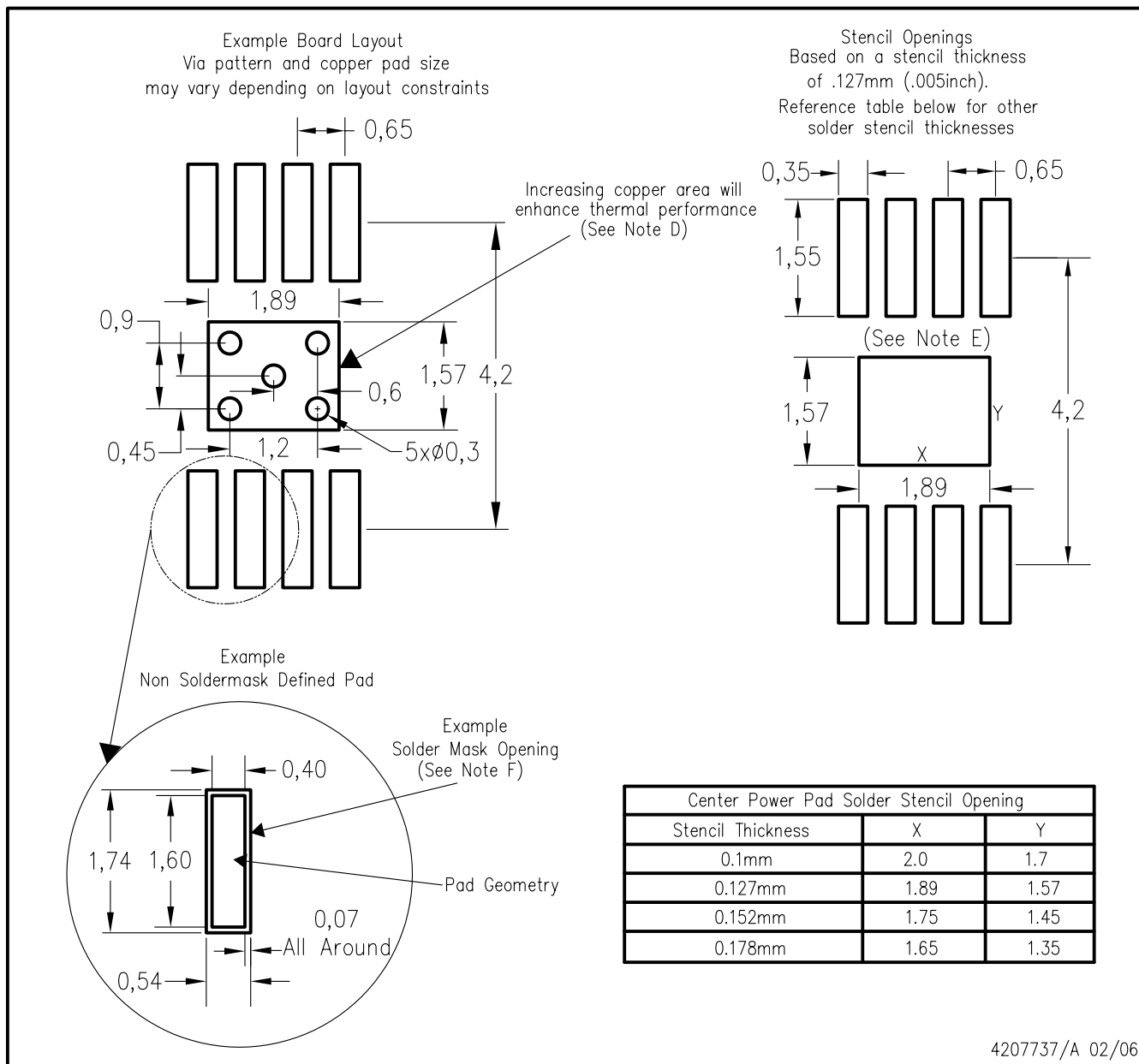

- NOTES:
- A. All linear dimensions are in millimeters.
  - B. This drawing is subject to change without notice.
  - C. Customers should place a note on the circuit board fabrication drawing not to alter the center solder mask defined pad.
  - D. This package is designed to be soldered to a thermal pad on the board. Refer to Technical Brief, PowerPad Thermally Enhanced Package, Texas Instruments Literature No. SLMA002, SLMA004, and also the Product Data Sheets for specific thermal information, via requirements, and recommended board layout. These documents are available at [www.ti.com](http://www.ti.com) <<http://www.ti.com>>. Publication IPC-7351 is recommended for alternate designs.
  - E. Laser cutting apertures with trapezoidal walls and also rounding corners will offer better paste release. Customers should contact their board assembly site for stencil design recommendations. Example stencil design based on a 50% volumetric metal load solder paste. Refer to IPC-7525 for other stencil recommendations.
  - F. Customers should contact their board fabrication site for solder mask tolerances between and around signal pads.

DRB (S-PDSO-N8)

PLASTIC SMALL OUTLINE

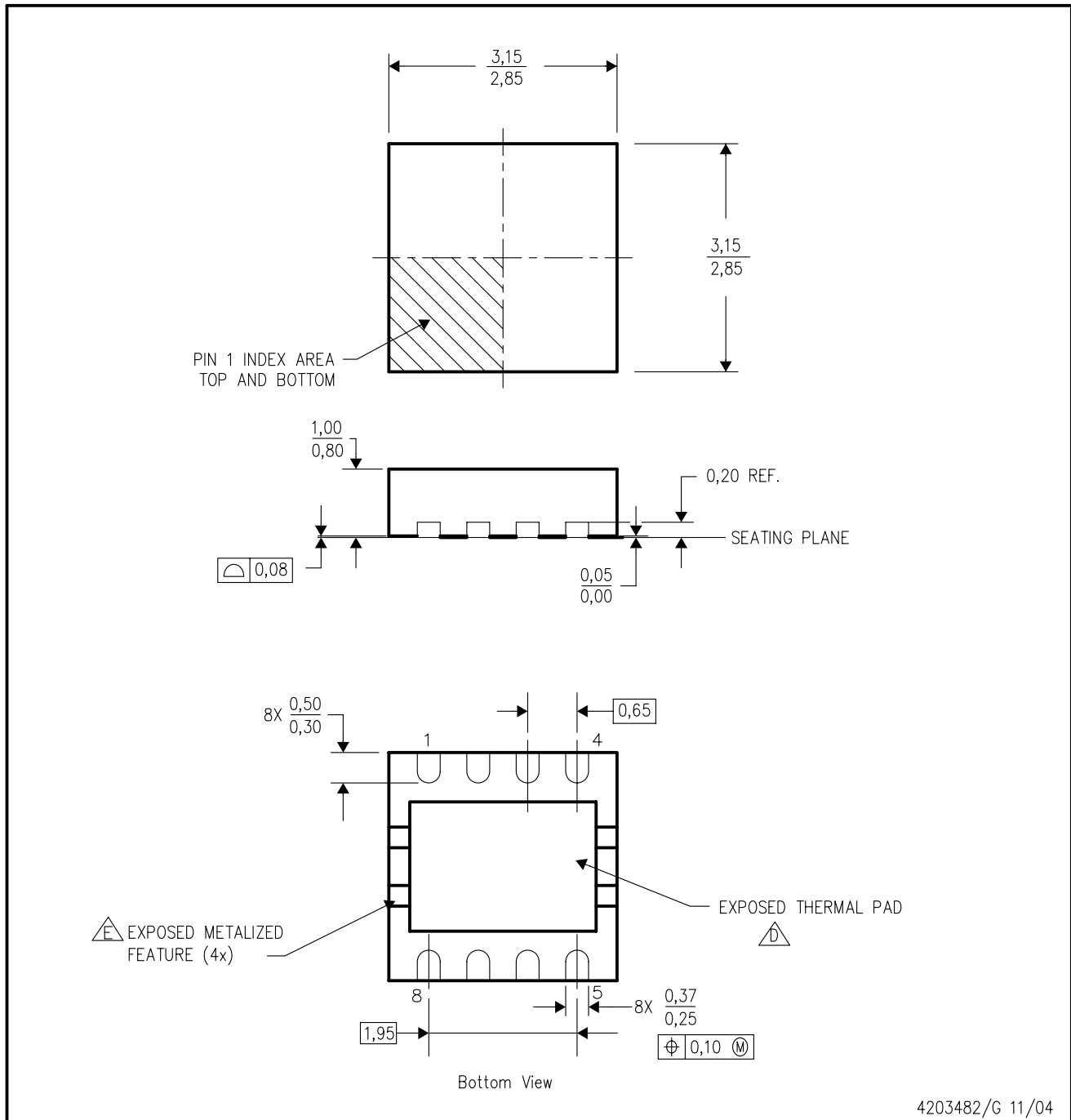

- NOTES:
- A. All linear dimensions are in millimeters. Dimensioning and tolerancing per ASME Y14.5M-1994.
  - B. This drawing is subject to change without notice.
  - C. Small Outline No-Lead (SON) package configuration.
  - The package thermal pad must be soldered to the board for thermal and mechanical performance. See the Product Data Sheet for details regarding the exposed thermal pad dimensions.
  - Metalized features are supplier options and may not be on the package.

THERMAL INFORMATION

This package incorporates an exposed thermal pad that is designed to be attached directly to an external heatsink. The thermal pad must be soldered directly to the printed circuit board (PCB). After soldering, the PCB can be used as a heatsink. In addition, through the use of thermal vias, the thermal pad can be attached directly to a ground or power plane (whichever is applicable), or alternatively, a special heatsink structure designed into the PCB. This design optimizes the heat transfer from the integrated circuit (IC).

For information on the Quad Flatpack No-Lead (QFN) package and its advantages, refer to Application Report, Quad Flatpack No-Lead Logic Packages, Texas Instruments Literature No. SCBA017. This document is available at [www.ti.com](http://www.ti.com).

The exposed thermal pad dimensions for this package are shown in the following illustration.

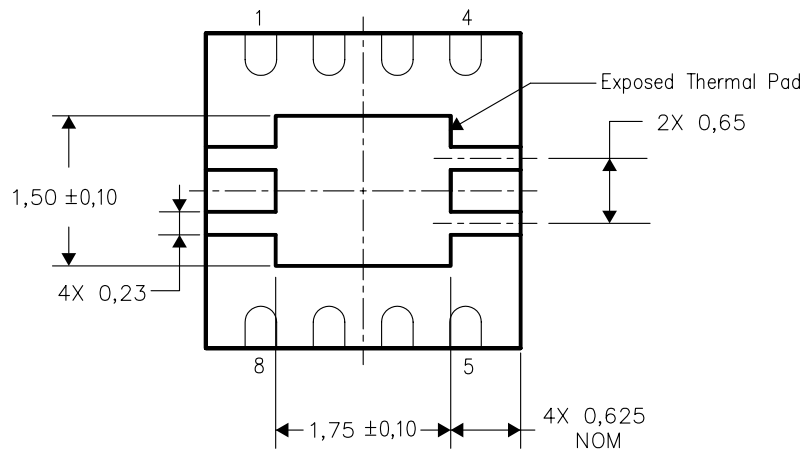

Bottom View

NOTE: All linear dimensions are in millimeters

Exposed Thermal Pad Dimensions

DRB (S-PDSO-N8)

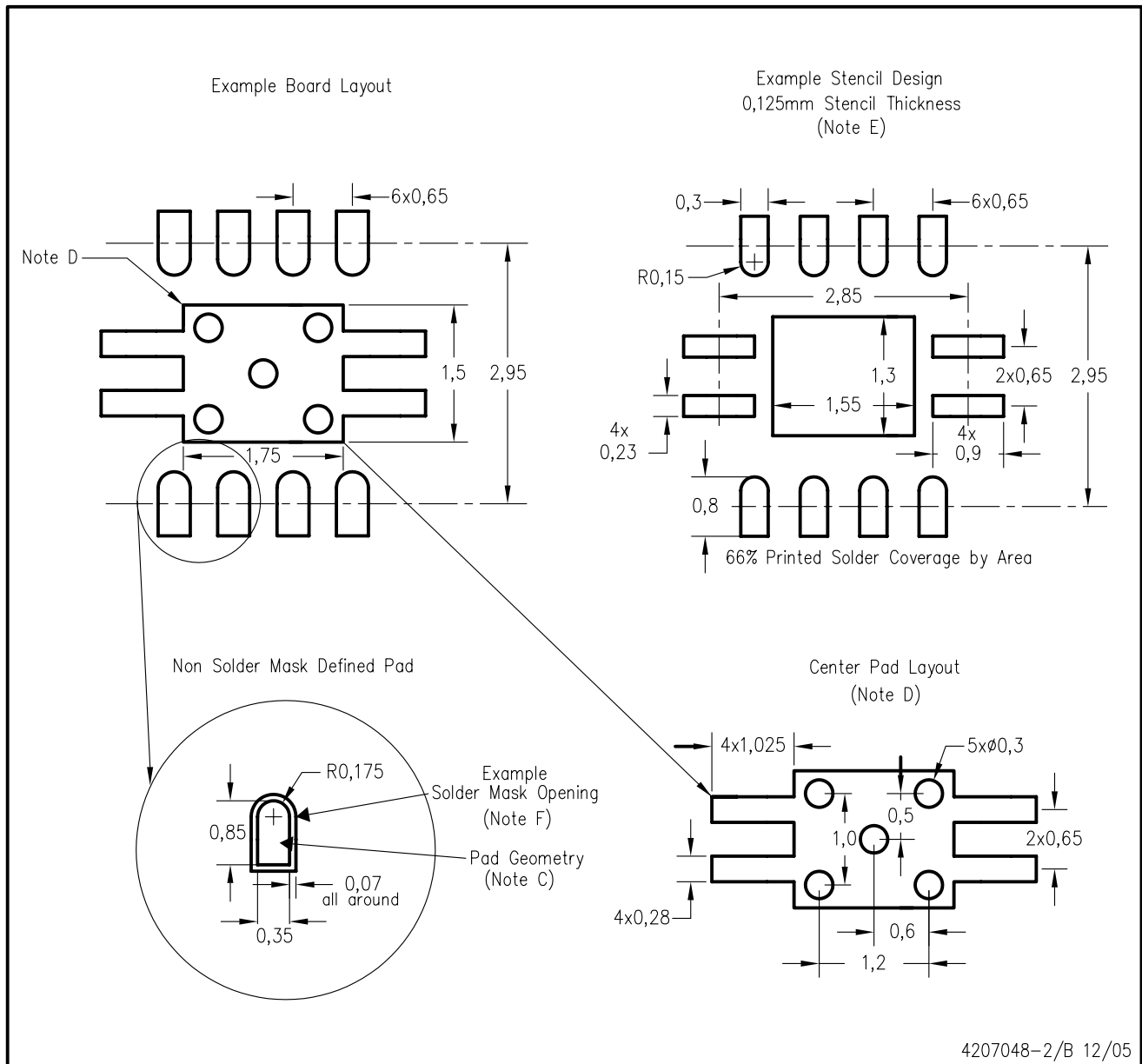

- NOTES:
- All linear dimensions are in millimeters.
  - This drawing is subject to change without notice.
  - Publication IPC-7351 is recommended for alternate designs.
  - This package is designed to be soldered to a thermal pad on the board. Refer to Application Note, QFN Packages, Texas Instruments Literature No. SCBA017, SLUA271, and also the Product Data Sheets for specific thermal information, via requirements, and recommended board layout. These documents are available at [www.ti.com](http://www.ti.com) <<http://www.ti.com>>.
  - Laser cutting apertures with trapezoidal walls and also rounding corners will offer better paste release. Customers should contact their board assembly site for stencil design recommendations. Refer to IPC 7525 for stencil design considerations.
  - Customers should contact their board fabrication site for solder mask tolerances.

## IMPORTANT NOTICE

Texas Instruments Incorporated and its subsidiaries (TI) reserve the right to make corrections, modifications, enhancements, improvements, and other changes to its products and services at any time and to discontinue any product or service without notice. Customers should obtain the latest relevant information before placing orders and should verify that such information is current and complete. All products are sold subject to TI's terms and conditions of sale supplied at the time of order acknowledgment.

TI warrants performance of its hardware products to the specifications applicable at the time of sale in accordance with TI's standard warranty. Testing and other quality control techniques are used to the extent TI deems necessary to support this warranty. Except where mandated by government requirements, testing of all parameters of each product is not necessarily performed.

TI assumes no liability for applications assistance or customer product design. Customers are responsible for their products and applications using TI components. To minimize the risks associated with customer products and applications, customers should provide adequate design and operating safeguards.

TI does not warrant or represent that any license, either express or implied, is granted under any TI patent right, copyright, mask work right, or other TI intellectual property right relating to any combination, machine, or process in which TI products or services are used. Information published by TI regarding third-party products or services does not constitute a license from TI to use such products or services or a warranty or endorsement thereof. Use of such information may require a license from a third party under the patents or other intellectual property of the third party, or a license from TI under the patents or other intellectual property of TI.

Reproduction of information in TI data books or data sheets is permissible only if reproduction is without alteration and is accompanied by all associated warranties, conditions, limitations, and notices. Reproduction of this information with alteration is an unfair and deceptive business practice. TI is not responsible or liable for such altered documentation.

Resale of TI products or services with statements different from or beyond the parameters stated by TI for that product or service voids all express and any implied warranties for the associated TI product or service and is an unfair and deceptive business practice. TI is not responsible or liable for any such statements.

Following are URLs where you can obtain information on other Texas Instruments products and application solutions:

<b>Products</b>		<b>Applications</b>	
Amplifiers	<a href="http://amplifier.ti.com">amplifier.ti.com</a>	Audio	<a href="http://www.ti.com/audio">www.ti.com/audio</a>
Data Converters	<a href="http://dataconverter.ti.com">dataconverter.ti.com</a>	Automotive	<a href="http://www.ti.com/automotive">www.ti.com/automotive</a>
DSP	<a href="http://dsp.ti.com">dsp.ti.com</a>	Broadband	<a href="http://www.ti.com/broadband">www.ti.com/broadband</a>
Interface	<a href="http://interface.ti.com">interface.ti.com</a>	Digital Control	<a href="http://www.ti.com/digitalcontrol">www.ti.com/digitalcontrol</a>
Logic	<a href="http://logic.ti.com">logic.ti.com</a>	Military	<a href="http://www.ti.com/military">www.ti.com/military</a>
Power Mgmt	<a href="http://power.ti.com">power.ti.com</a>	Optical Networking	<a href="http://www.ti.com/opticalnetwork">www.ti.com/opticalnetwork</a>
Microcontrollers	<a href="http://microcontroller.ti.com">microcontroller.ti.com</a>	Security	<a href="http://www.ti.com/security">www.ti.com/security</a>
Low Power Wireless	<a href="http://www.ti.com/lpw">www.ti.com/lpw</a>	Telephony	<a href="http://www.ti.com/telephony">www.ti.com/telephony</a>
		Video & Imaging	<a href="http://www.ti.com/video">www.ti.com/video</a>
		Wireless	<a href="http://www.ti.com/wireless">www.ti.com/wireless</a>

Mailing Address: Texas Instruments  
Post Office Box 655303 Dallas, Texas 75265