

1. General Description

This EPROM-Based 8-bit micro-controller uses a fully static CMOS design technology to achieve high speed, small size, low power and high noise immunity.

On chip memory includes 0.5K words EPROM and 80 bytes static RAM.

Four comparator inputs with external Vref (not for 18 pin package) are also provided.

XTAL - Standard crystal oscillator

HFXT - High frequency crystal oscillator

- ◆ 4 oscillator start-up time can be selected by programming option:
150 μ s, 20 ms, 40 ms, 80 ms
- ◆ On-chip RC oscillator based Watchdog Timer(WDT) can be operated freely
- ◆ 12 I/O(for 18 pins package), 14 I/O(for 20 pins package), 16 I/O(for 22/24 pins package) pins with their own independent direction control

2. Features

- ◆ Fully CMOS static design
- ◆ 8-bit data bus
- ◆ On chip EPROM size : 0.5 K words
- ◆ Internal RAM size : 80 bytes
(72 general purpose registers, 8 special registers)
- ◆ 36 single word instructions
- ◆ 14-bit instructions
- ◆ 2-level stacks
- ◆ Operating voltage : 2.3V ~ 5.5 V
- ◆ Operating frequency : 0 ~ 20 MHz
- ◆ The most fast execution time is 200 ns under 20 MHz in all single cycle instructions except the branch instruction
- ◆ Addressing modes include direct, indirect and relative addressing modes
- ◆ Built-in Power-on Reset
- ◆ 4 Channel comparator
- ◆ Power edge-detector Reset
- ◆ Sleep Mode for power saving
- ◆ 8-bit real time clock/counter(RTCC) with 8-bit programmable prescaler
- ◆ 4 types of oscillator can be selected by programming option:
RC - Low cost RC oscillator
LFXT - Low frequency crystal oscillator

3. Applications

The application areas of this MDT10P21 range from appliance motor control and high speed automotive to low power remote transmitters/receivers, pointing devices, and telecommunications processors, such as Remote controller, small instruments, chargers, toy, automobile and PC peripheral ... etc

4. Pin Assignment

A1 : 20PINS, A2 : 22PINS,

A3 : 24PINS, A5 : 18 PINS

P - PDIP, S - SOP, K - SKINNY

A1P,A1S

PA5	1	20	PA4/VREF
PA2/CIC2	2	19	PA1/CIC1
PA3/CIC3	3	18	PA0/CIC0
RTCC	4	17	OSC1
/MCLR	5	16	OSC2
Vss	6	15	Vdd
PB0	7	14	PB7
PB1	8	13	PB6
PB2	9	12	PB5
PB3	10	11	PB4

A3S

NC	1	24	NC
PA7	2	23	PA6
PA5	3	22	PA4/VREF
PA2/CIC2	4	21	PA1/CIC1
PA3/CIC3	5	20	PA0/CIC0
RTCC	6	19	OSC1
/MCLR	7	18	OSC2
Vss	8	17	Vdd
PB0	9	16	PB7
PB1	10	15	PB6
PB2	11	14	PB5
PB3	12	13	PB4

A2K

PA7	1	22	PA6
PA5	2	21	PA4/VREF
PA2/CIC2	3	20	PA1/CIC1
PA3/CIC3	4	19	PA0/CIC0
RTCC	5	18	OSC1
/MCLR	6	17	OSC2
Vss	7	16	Vdd
PB0	8	15	PB7
PB1	9	14	PB6
PB2	10	13	PB5
PB3	11	12	PB4

A5P,A5S

PA2/CIC2	1	18	PA1/CIC1
PA3/CIC3	2	17	PA0/CIC0
RTCC	3	16	OSC1
/MCLR	4	15	OSC2
Vss	5	14	Vdd
PB0	6	13	PB7
PB1	7	12	PB6
PB2	8	11	PB5
PB3	9	10	PB4

5. Block Diagram

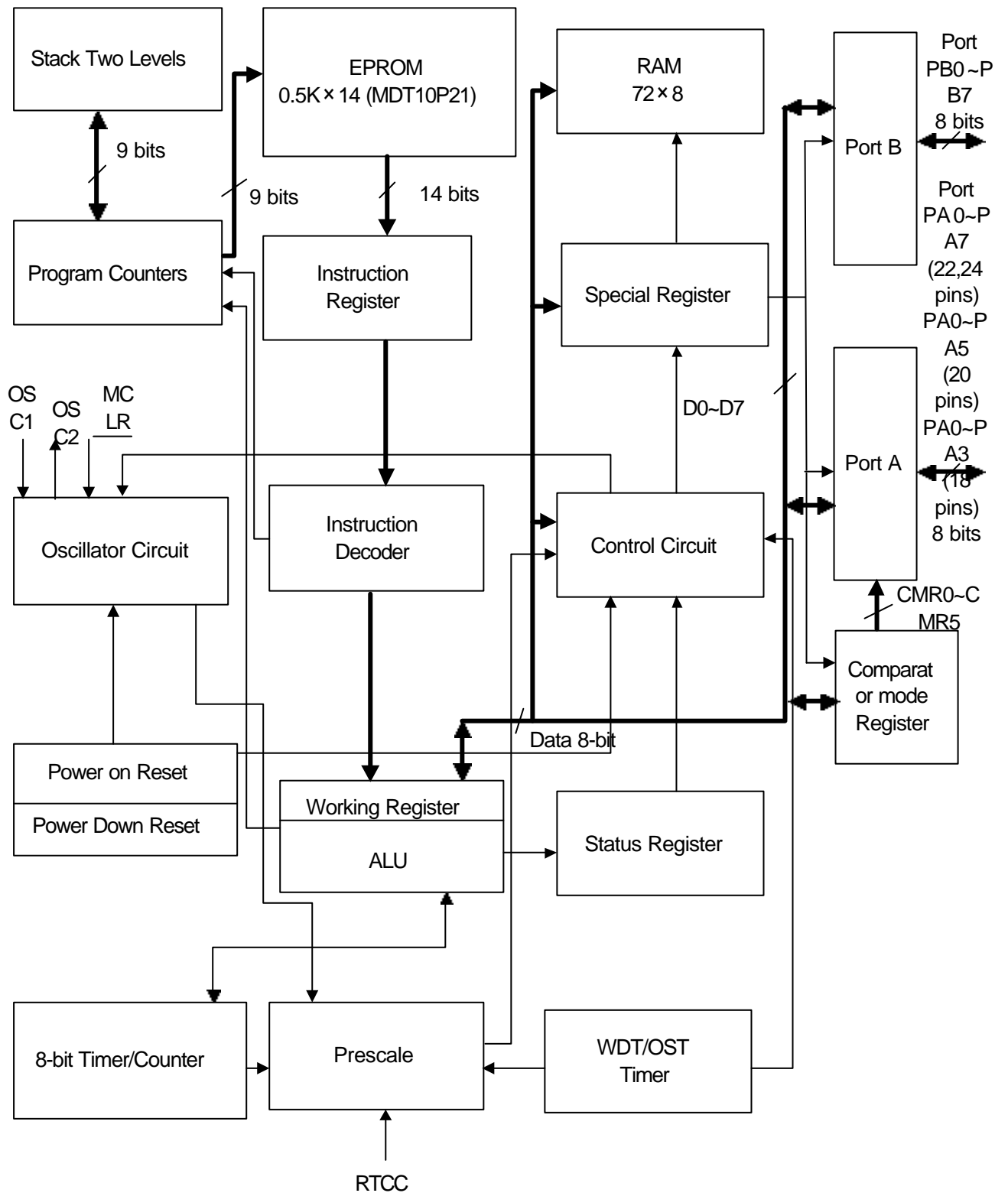

6. Pin Function Description

Pin Name	I/O	Function Description
PA0~PA7	I/O	PA0~PA3 : TTL input level or comparator input PA4 : TTL input level or comparator VREF input PA5~PA7 : TTL input level
PB0~PB7	I/O	Port B, TTL input level
RTCC	I	Real Time Clock/Counter, Schmitt Trigger input levels
/MCLR	I	Master Clear, Schmitt Trigger input levels
OSC1	I	Oscillator Input
OSC2	O	Oscillator Output
Vdd		Power supply
Vss		Ground
NC		Unused ,do not connect

7. Memory Map

(A) Register Map

Address	Description
00	Indirect Addressing Register
01	RTCC
02	PC
03	STATUS
04	MSR
05	Port A
06	Port B
07	Control register for comparator
08~0F	Internal RAM, General Purpose Register
10~1F	Internal RAM, Memory bank 0
30~3F	Internal RAM, Memory bank 1
50~5F	Internal RAM, Memory bank 2
70~7F	Internal RAM, memory bank 3

- (1) IAR (Indirect Address Register) : R0
- (2) RTCC (Real Time Counter/Counter Register) : R1
- (3) PC (Program Counter) : R2

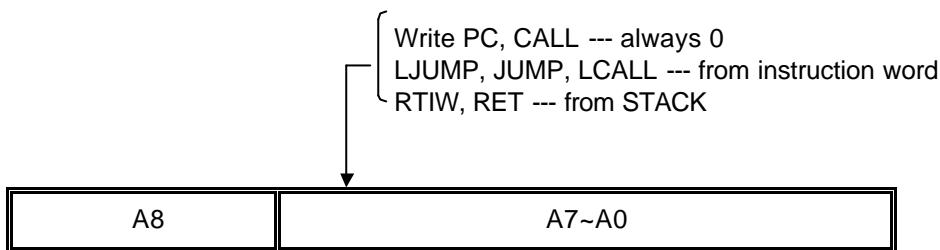

Write PC --- from ALU
 LJUMP, JUMP, LCALL, CALL --- from instruction word
 RTIW, RET --- from STACK

- (4) STATUS (Status register) : R3

Bit	Symbol	Function
0	C	Carry bit
1	HC	Half Carry bit
2	Z	Zero bit
3	PF	Power loss Flag bit
4	TF	Time overflow Flag bit
5-7	—	General purpose bit

- (5) MSR (Memory Select Register) : R4

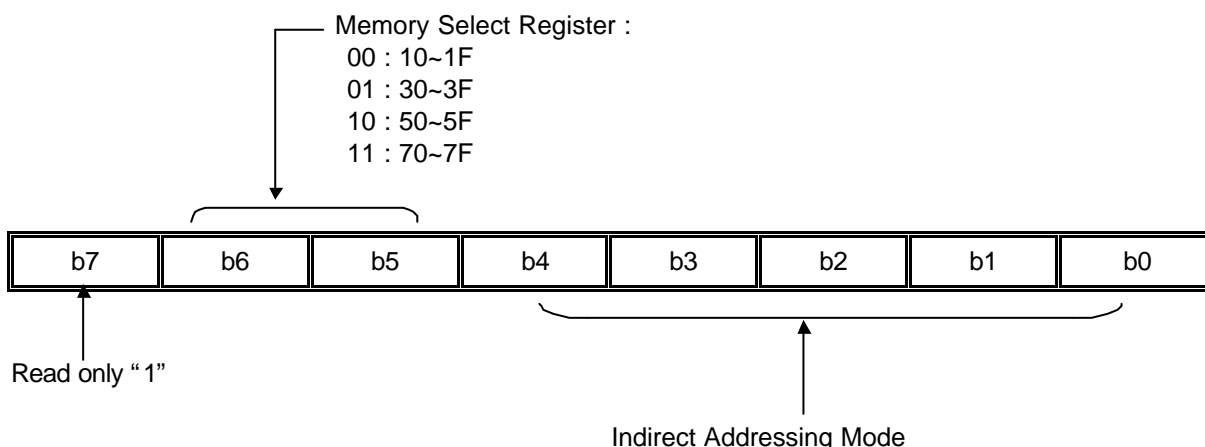

- (6) PORT A : R5
- PA7~PA0, I/O Register for 22, 24 pins
 PA5~PA0, I/O Register for 20 pins
 PA3~PA0, I/O Register for 18 pins

(7) PORT B : R6
PB7~PB0, I/O Register

(8) CMR(Comparator Mode Register) : R7

Bit	Function
0	0: Define PA0 as TTL input 1: Define PA0 as comparator input
1	0: Define PA1 as TTL input 1: Define PA1 as comparator input
2	0: Define PA2 as TTL input 1: Define PA2 as comparator input
3	0: Define PA3 as TTL input 1: Define PA3 as comparator input
5:4	Reference Voltage select 00: 1/4 VDD 01: 1/2 VDD 10: 3/4 VDD 11: VREF (External pin and PA4 must be set to input)
7:6	Register bits

(9) TMR (Time Mode Register)

Bit	Symbol	Function		
		Prescaler Value	RTCC rate	WDT rate
2—0	PS2—0	0 0 0	1 : 2	1 : 1
		0 0 1	1 : 4	1 : 2
		0 1 0	1 : 8	1 : 4
		0 1 1	1 : 16	1 : 8
		1 0 0	1 : 32	1 : 16
		1 0 1	1 : 64	1 : 32
		1 1 0	1 : 128	1 : 64
		1 1 1	1 : 256	1 : 128
3	PSC	Prescaler assignment bit : 0 — RTCC 1 — Watchdog Timer		
4	TCE	RTCC signal Edge : 0 — Increment on low-to-high transition on RTCC pin 1 — Increment on high-to-low transition on RTCC pin		
5	TCS	RTCC signal set : 0 — Internal instruction cycle clock 1 — Transition on RTCC pin		

(10) CPIO A, CPIO B (Control Port I/O Mode Register)

The CPIO register is "write-only"

= "0", I/O pin in output mode;

= "1", I/O pin in input mode.

(11) EPROM Option by writer programming :

A. FIRST WORD

Oscillator Type	Oscillator Start-up Time
RC Oscillator	150 μ s
LFXT Oscillator	20 ms
XTAL Oscillator	40 ms
HFXT Oscillator	80 ms

Watchdog Timer control
Watchdog timer disable all the time
Watchdog timer enable all the time

Power Edge Detect
PED Disable
PED Enable

Security bit
Security Disable
Security Enable

(B) Program Memory

Address	Description
000- 1FF	Program memory
1FF	The starting address of the power on, external reset or WDT

8. Reset Condition for all Registers

Register	Address	Power-On Reset	/MCLR Reset	WDT Reset
CPIO A	- -	1111 1111	1111 1111	1111 1111
CPIO B	- -	1111 1111	1111 1111	1111 1111
TMR	- -	--11 1111	--11 1111	--11 1111
IAR	00h	-	-	-
RTCC	01h	xxxx xxxx	uuuu uuuu	uuuu uuuu
PC	02h	1111 1111	1111 1111	1111 1111

This specification are subject to be changed without notice. Any latest information

Register	Address	Power-On Reset	/MCLR Reset	WDT Reset
STATUS	03h	0001 1xxx	000# #uuu	000# #uuu
MSR	04h	100x xxxx	100u uuuu	1uuu uuuu
PORT A	05h	xxxx xxxx	uuuuuuuu	uuuu uuuu
PORT B	06h	xxxx xxxx	uuuu uuuu	uuuu uuuu
CMR	07h	0000 0000	uuuu uuuu	uuuu uuuu

Note : u = unchanged, x = unknown, - = unimplemented, read as "0"

= value depends on the condition of the following table

Condition	Status: bit 4	Status: bit 3
/MCLR reset (not during SLEEP)	U	u
/MCLR reset during SLEEP	1	0
WDT reset (not during SLEEP)	0	1
WDT reset during SLEEP	0	0

9. Instruction Set

Instruction Code	Mnemonic Operands	Function	Operating	Status
010000 00000000	NOP	No operation	None	
010000 00000001	CLRWT	Clear Watchdog timer	0 WT	TF, PF
010000 00000010	SLEEP	Sleep mode	0 WT, stop OSC	TF, PF
010000 00000011	TMODE	Load W to TMODE register	W TMODE	None
010000 00000100	RET	Return	Stack PC	None
010000 00000rrr	CPIO R	Control I/O port register	W CPIO r	None
010001 1rrrrrrr	STWR R	Store W to register	W R	None
011000 trrrrrrr	LDR R, t	Load register	R t	Z
111010 iiiiii	LDWI I	Load immediate to W	I W	None
010111 trrrrrrr	SWAPR R, t	Swap halves register	[R(0~3)↔R(4~7)] t	None
011001 trrrrrrr	INCR R, t	Increment register	R + 1 t	Z
011010 trrrrrrr	INCRSZ R, t	Increment register, skip if zero	R + 1 t	None
011011 trrrrrrr	ADDWR R, t	Add W and register	W + R t	C, HC, Z
011100 trrrrrrr	SUBWR R, t	Subtract W from register	R - W t (R+/W+1 t)	C, HC, Z
011101 trrrrrrr	DECR R, t	Decrement register	R - 1 t	Z
011110 trrrrrrr	DECRSZ R, t	Decrement register, skip if zero	R - 1 t	None
010010 trrrrrrr	ANDWR R, t	AND W and register	R W t	Z

Instruction Code	Mnemonic Operands	Function	Operating	Status
110100 iiiiii	ANDWI i	AND W and immediate	i W W	Z
010011 trrrrrr	IORWR R, t	Inclu. OR W and register	R W t	Z
110101 iiiiii	IORWI i	Inclu. OR W and immediate	i W W	Z
010100 trrrrrr	XORWR R, t	Exclu. OR W and register	R W t	Z
110110 iiiiii	XORWI i	Exclu. OR W and immediate	i W W	Z
011111 trrrrrr	COMR R, t	Complement register	/R t	Z
010110 trrrrrr	RRR R, t	Rotate right register	R(n) R(n-1), C R(7), R(0) C	C
010101 trrrrrr	RLR R, t	Rotate left register	R(n) r(n+1), C R(0), R(7) C	C
010000 1xxxxxxx	CLRW	Clear working register	0 W	Z
010001 0rrrrrr	CLRR R	Clear register	0 R	Z
0000bb brrrrrr	BCR R, b	Bit clear	0 R(b)	None
0010bb brrrrrr	BSR R, b	Bit set	1 R(b)	None
0001bb brrrrrr	BTSC R, b	Bit Test, skip if clear	Skip if R(b)=0	None
0011bb brrrrrr	BTSS R, b	Bit Test, skip if set	Skip if R(b)=1	None
100nnn nnnnnnn	LCALL n	Long CALL subroutine	n PC, PC+1 Stack	None
101nnn nnnnnnn	LJUMP n	Long JUMP to address	n PC	None
110000 nnnnnnn	CALL n	Call subroutine	n PC, PC+1 Stack	None
110001 iiiiii	RTIW i	Return, place immediate to W	Stack PC,i W	None
11001n nnnnnnn	JUMP n	JUMP to address	n PC	None

Note :

W	: Working register	b	: Bit position
WT	: Watchdog timer	t	: Target
TMODE	: TMODE mode register	0	: Working register
CPIO	: Control I/O port register	1	: General register
TF	: Timer overflow flag	R	: General register address
PF	: Power loss flag	C	: Carry flag
PC	: Program Counter	HC	: Half carry
OSC	: Oscillator	Z	: Zero flag
Inclu.	: Inclusive ' '	/	: Complement
Exclu.	: Exclusive ' '	x	: Don't care
AND	: Logic AND ' '	i	: Immediate data (8 bits)
		n	: Immediate address

10. Electrical Characteristics

(Operating temperature at 25 °C).

Sym	Description	Condition	Min	Typ	Max	Unit
V _{dd}	Operating voltage		2.3		6.3	V
V _{IL}	Input Low Voltage PA, PB	V _{dd} =5V	-0.6		1.0	V
		RTCC, /MCLR V _{dd} =5V	-0.6		1.0	V
V _{IH}	Input high Voltage PA, PB	V _{dd} =5V	2.0		V _{dd}	V
		RTCC, /MCLR V _{dd} =5V	3.2		V _{dd}	V
I _{IL}	Input leakage current	V _{dd} =5V			+/-1	μA
V _{OL}	Output Low Voltage PA, PB	V _{dd} =5V, I _{OL} =20mA		0.4		V
		V _{dd} =5V, I _{OL} =5mA		0.1		V
V _{OH}	Output High Voltage PA, PB	V _{dd} =5V, I _{OH} = -20mA		3.8		V
		V _{dd} =5V, I _{OH} = -5mA		4.5		V
I _{slp}	Sleep current (WDT disable)	V _{dd} = 2.3 ~ 6.3 V		0.1	1.0	μA
I _{slp}	Sleep current (WDT enable)	V _{dd} = 2.3 V		1		μA
		V _{dd} = 3.0 V		3		μA
		V _{dd} = 4.0 V		8		μA
		V _{dd} = 5.0 V		17		μA
		V _{dd} = 6.3 V		36		μA
V _{pr}	Power Edge-detector Reset Voltage		1.1		1.3	V
T _{wdt}	The basic WDT time-out cycle time	V _{dd} = 2.3 V		27.0		mS
		V _{dd} = 3.0 V		23.2		mS
		V _{dd} = 4.0 V		20.4		mS
		V _{dd} = 5.0 V		18.4		mS
		V _{dd} = 6.3 V		16.8		mS
T _{FLT}	/MCLR filter	V _{dd} = 5.0 V		600		nS
I _{cc}	Comparator Supply current (one comparator)	V _{dd} =5.0v		15		μA
V _{ref}	Input reference voltage	V _{dd} =2.5v ~6.3v			V _{dd} -0.8v	V
---	Comparator Response time V ₋ =V _{dd} /4, V ₊ =V ₋ ± 0.2v V ₋ =V _{dd} /2, V ₊ =V ₋ ± 0.2v V ₋ =V _{dd} 3/4, V ₊ =V ₋ ± 0.2v V ₋ =V _{DD} -0.8, V ₊ =V _± 0.2v	V _{dd} =5.0v, V ₋ = V _{ref} V ₊ = (PA0~PA3)		8		μS
				8		μS
				8		μS
				8		μS

This specification are subject to be changed without notice. Any latest information

11. Operating Current

Temperature = 25 , the typical value as followings :

11.1 OSC Type = RC ; WDT - Enable; Comparator - Disable @ V_{dd} = 5.0 V

Cext. (F)	Rext. (Ohm)	Frequency (Hz)	Current (A)
3P	4.7 K	10.5M	1.35 mA
	10.0 K	5.36M	750 μA
	47.0 K	1.24M	250 μA
	100.0 K	589K	180 μA
	300.0 K	200K	130 μA
	470.0 K	126K	120 μA
20P	4.7 K	5.6M	770 μA
	10.0 K	2.85M	460 μA
	47.0 K	640K	190 μA
	100.0 K	300K	150 μA
	300.0 K	104K	125 μA
	470.0 K	64K	115 μA
100P	4.7 K	1.68M	310 μA
	10.0 K	834K	210 μA
	47.0 K	182K	125 μA
	100.0 K	87.6K	118 μA
	300.0 K	29.6K	110 μA
	470.0 K	18.6K	105 μA
300P	4.7 K	748K	200 μA
	10.0 K	367K	155 μA
	47.0 K	80K	115 μA
	100.0 K	38K	110 μA
	300.0 K	12.8K	105 μA
	470.0 K	8K	100 μA

11.2 OSC Type = LF (C=20 p); WDT - Disable ; Comparator - Disable

Voltage/Frequency	32 K	455 K	1 M	Sleep
2.1 V	3.0uA	@2.6v 32.0uA	@2.2v 42.0uA	< 1.0 μ A
3.0 V	6.0uA	45uA	60uA	< 1.0 μ A
4.0 V	12.0uA	65uA	100uA	< 1.0 μ A
5.0 V	30.0uA	100uA	150uA	< 1.0 μ A
6.3 V	110uA	185uA	260uA	< 1.0 μ A

11.3 OSC Type = XT (C=10 p); WDT - Enable ; Comparator - Disable

Voltage/Frequency	1 M	4 M	10 M	Sleep
2.1 V	65uA	200uA	360uA	< 1.0 μ A
3.0 V	136uA	350uA	650uA	3 μ A
4.0 V	252uA	550uA	1.0mA	8 μ A
5.0 V	422uA	820uA	1.6mA	17 μ A
6.3 V	810uA	1.36mA	2.2mA	36 μ A

11.4 OSC Type = HF (C=10 p); WDT - Enable ; Comparator - Disable

Voltage/Frequency	4 M	10 M	20 M	Sleep
2.1 V	200uA	450uA	@2.2v 940uA	< 1.0 μ A
3.0 V	410uA	810uA	1.37mA	3 μ A
4.0 V	620uA	1.30mA	2.0mA	8 μ A
5.0 V	1mA	1.70mA	3.0mA	17 μ A
6.3 V	1.56mA	2.50mA	4.0mA	36 μ A

11.5 Power Edge-detector Reset Voltage (Not in Sleep Mode), @ $V_{dd} = 5.0$ V

V_{pr} 2.1~2.2 V

$V_{pr} : V_{dd}$ (Power Supply)

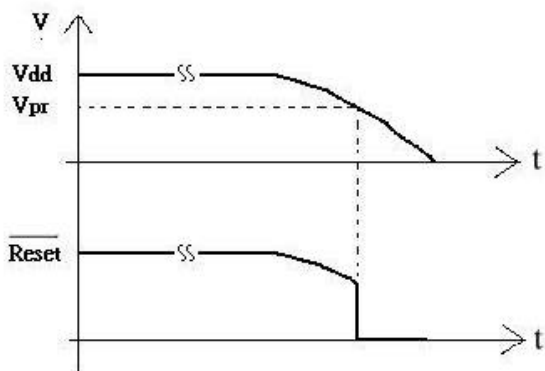

12. Port A Equivalent Circuit

PA0-PA3

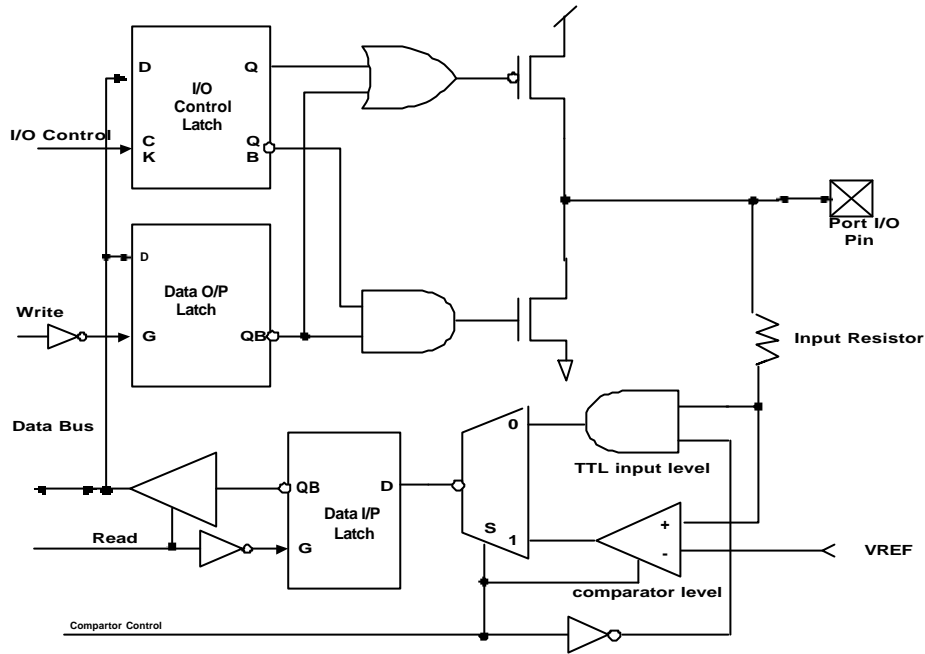

PA4

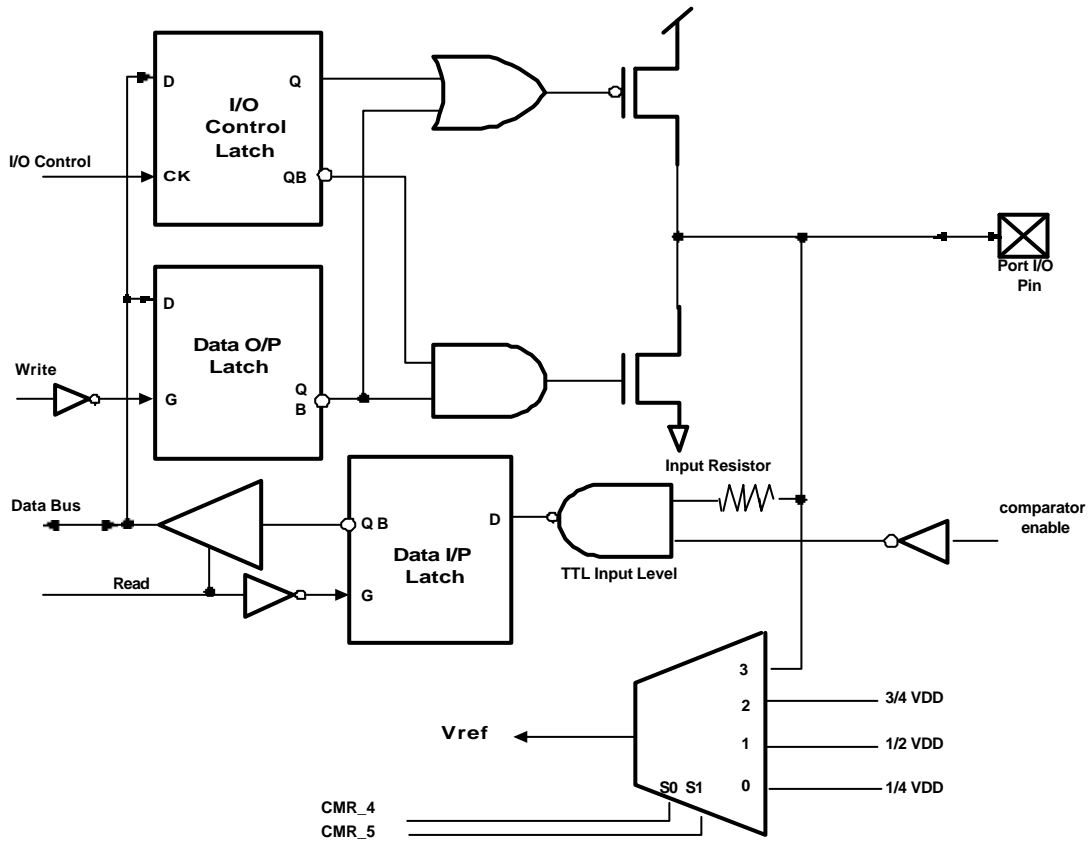

PA5-PA7

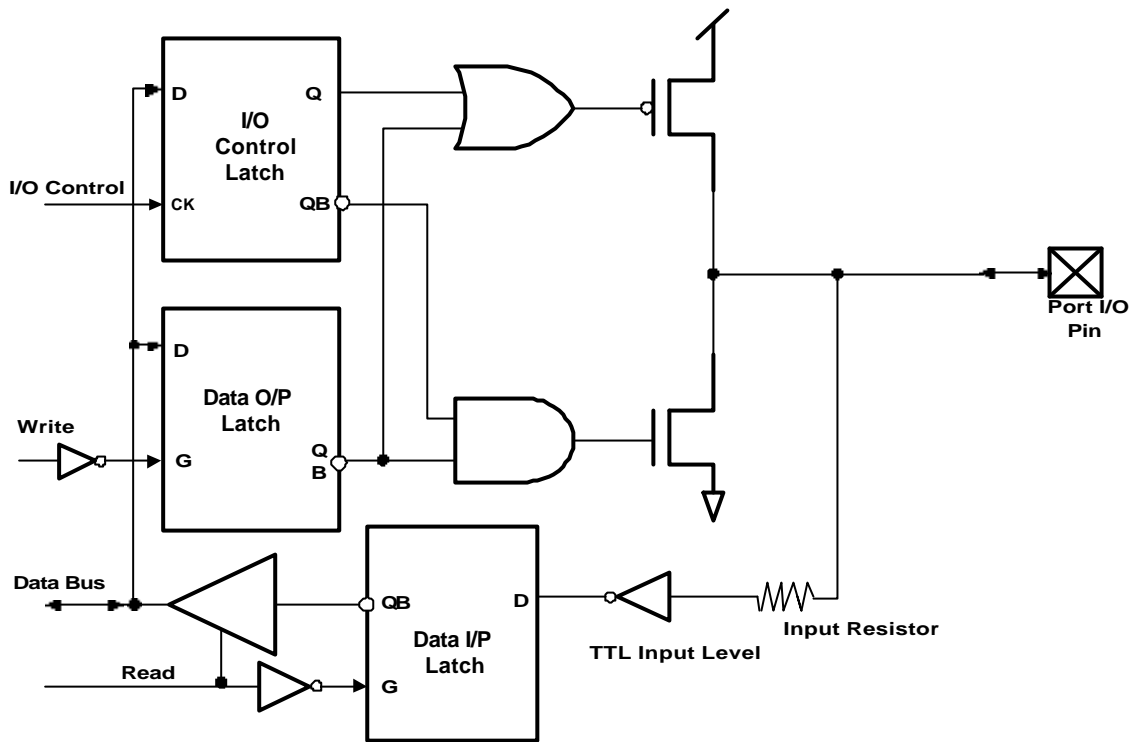

Port B Equivalent Circuit

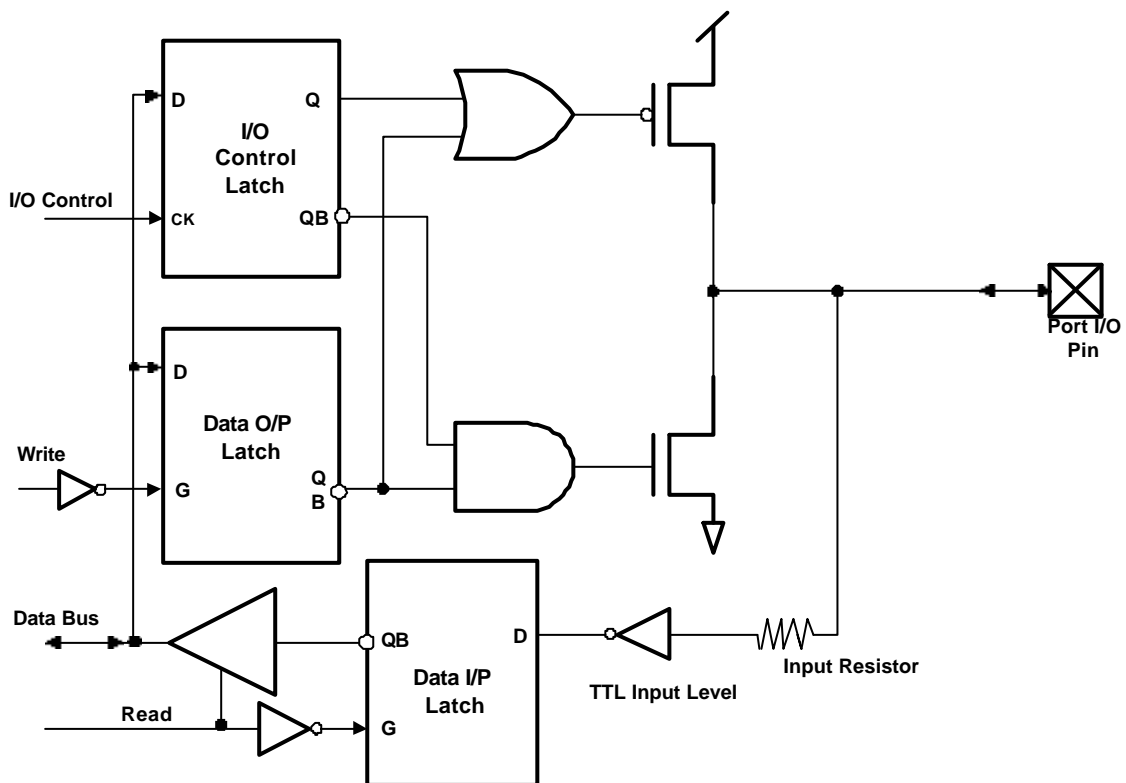

13. MCLR and RTCC Input Equivalent Circuit

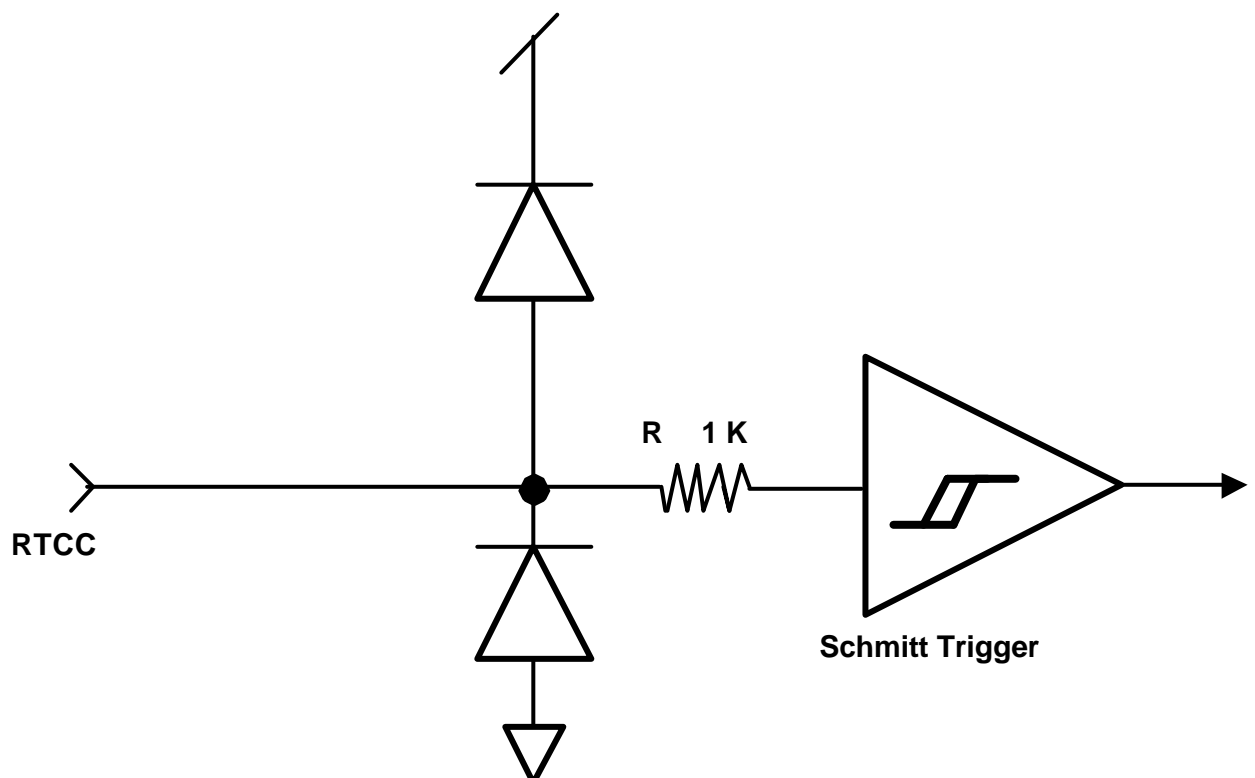
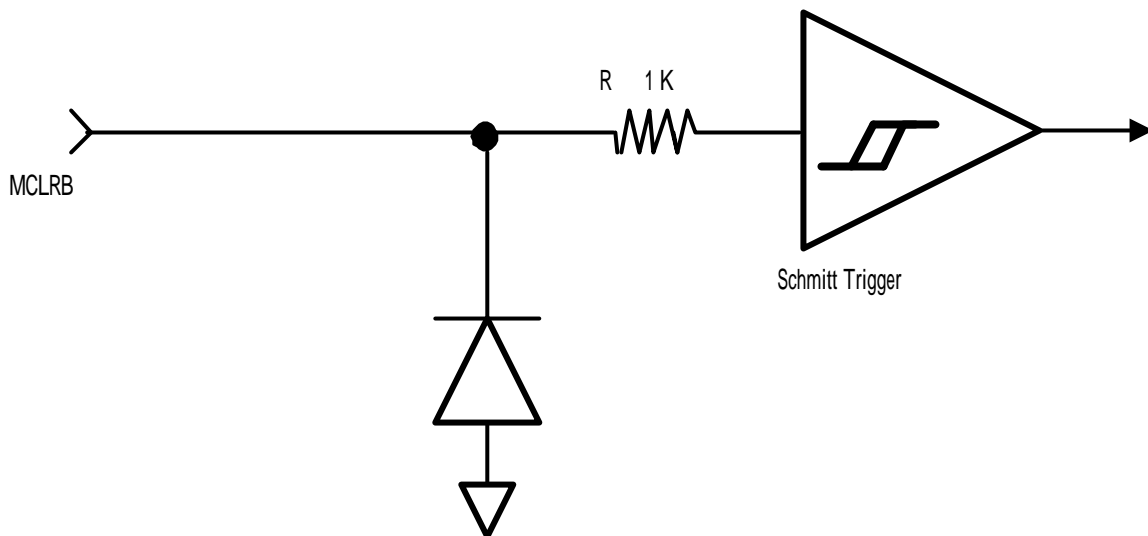

14. External Capacitor Selection For Crystal Oscillator

@ $V_{dd} = 5.0\text{ V}$

Osc. Type	Resonator Freq.	Capacity Range
HF	20 MHz	10 pF ~ 50 pF
	10 MHz	20 pF ~ 50 pF
	4 MHz	10 pF ~ 30 pF
XT	10 MHz	10 pF ~ 50 pF
	4 MHz	10 pF ~ 50 pF
	1 MHz	20 pF ~50 pF
LF	1 MHz	20 pF ~ 30 pF
	455 K	20 pF ~30 pF
	32 K	20 pF ~30 pF

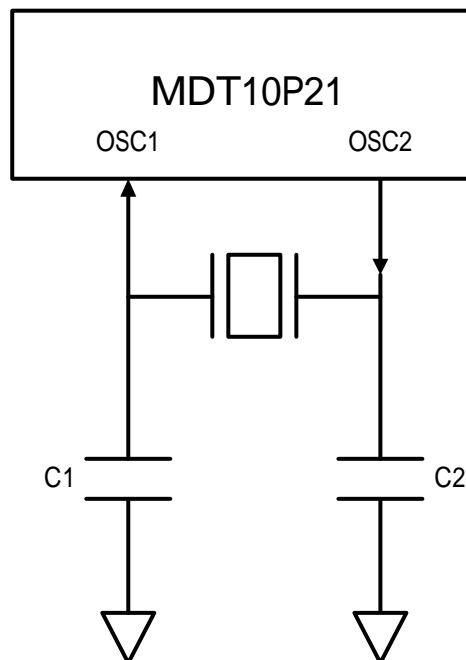

To increase the stability of oscillator and the ability of anti-noise, the above values of the external capacitor are for reference only, but the higher capacitance also increases the start-up time.

This datasheet has been downloaded from:

www.DatasheetCatalog.com

Datasheets for electronic components.