

SURFACE MOUNT PTC SN (1206) MODEL

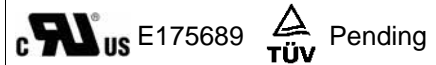

FEATURES

- 1206 Dimension, surface mount, solid state
- Faster time to trip than standard SMD devices
- Lower resistance than standard SMD devices
- Operation current: 50mA~1.5 A
- Maximum voltage: 6V~60Vdc
- Temperature range: -40 to 85
- Tape and reel available on most models

APPLICATIONS

- ◆ Almost anywhere there High-density boards is a low voltage power supply and a load to be protected including:
 - Computers & peripherals
 - General electronics
 - Automotive applications

PART NUMBERING SYSTEM

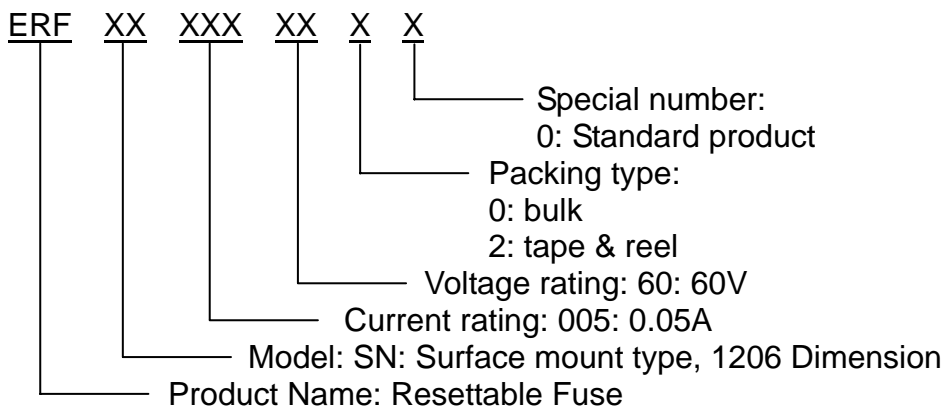

Marking system



Example

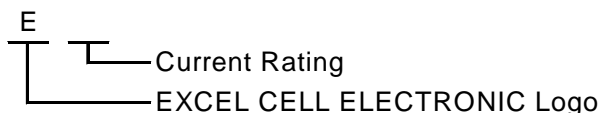

- EZ=ERFSN005-60
- EA=ERFSN010-60
- EB=ERFSN020-30
- EC=ERFSN035-16
- ED=ERFSN050-08
- EE=ERFSN075-06
- EF=ERFSN100-06
- EG=ERFSN150-06

NOTE: Specifications subject to change without prior notice.

Electrical characteristics(23)

Part Number	Hold Current	Trip Current	Rated Voltage	Maximum Current	Typical Power	Max. Time to trip		Resistance Tolerance	
	I _H , A	I _T , A	V _{MAX} , V _{dc}	I _{MAX} , A	P _d , W	Amp	Sec	R _{MIN}	R _{1MAX}
SN005	0.05	0.15	60	10	0.4	0.25	1.50	3.60	50.00
SN010	0.10	0.25	60	10	0.4	0.50	1.00	1.60	15.00
SN020	0.20	0.40	30	10	0.4	8.00	0.05	0.60	2.50
SN035	0.35	0.75	16	40	0.4	8.00	0.10	0.30	1.20
SN050	0.50	1.00	8	40	0.4	8.00	0.10	0.15	0.70
SN075	0.75	1.50	6	40	0.6	8.00	0.20	0.10	0.29
SN100	1.00	1.80	6	40	0.6	8.00	0.30	0.055	0.210
SN150	1.50	3.00	6	40	0.8	8.00	1.00	0.040	0.120

I_H=Hold current-maximum current at which the device will not trip at 23 °C still air.

I_T=Trip current-minimum current at which the device will always trip at 23 °C still air.

V_{MAX}=Maximum voltage device can withstand without damage at rated current.

I_{MAX}= Maximum fault current device can withstand without damage at rated voltage (V max).

P_d=Typical power dissipated from device when in the tripped state in 23 °C still air environment.

R_{MIN}=Minimum device resistance at 23 °C.

R_{1MAX}=Maximum device resistance at 23 °C 1 hour after tripping .

Typical time-to-trip-at 23

Z=SN005
A=SN010
B=SN020
C=SN035
D=SN050
E=SN075
F=SN100
G=SN150

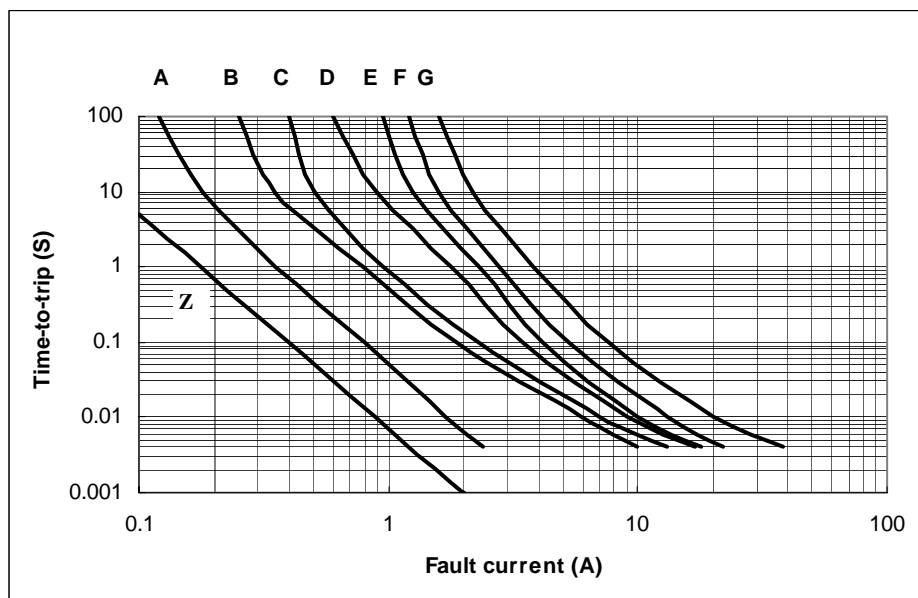

NOTE: Specifications subject to change without prior notice.

Thermal Derating Curve

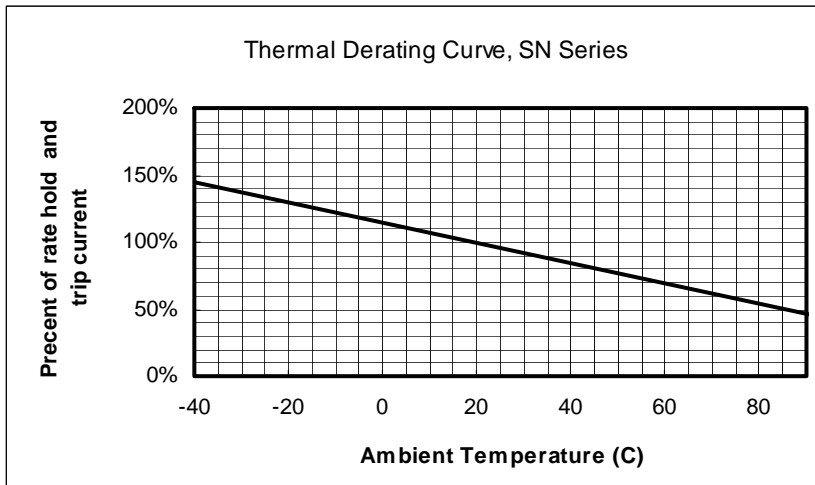

SN Product Dimensions (UNIT: mm)

Part Number	A		B		C		D
	Min	Max	Min	Max	Min	Max	Min
SN005	3.0	3.5	1.50	1.80	0.45	0.75	0.10
SN010	3.0	3.5	1.50	1.80	0.45	0.75	0.10
SN020	3.0	3.5	1.50	1.80	0.45	0.75	0.10
SN035	3.0	3.5	1.50	1.80	0.45	0.75	0.10
SN050	3.0	3.5	1.50	1.80	0.45	0.75	0.10
SN075	3.0	3.5	1.50	1.80	0.45	1.25	0.10
SN100	3.0	3.5	1.50	1.80	0.75	1.25	0.10
SN150	3.0	3.5	1.50	1.80	1.45	1.25	0.10

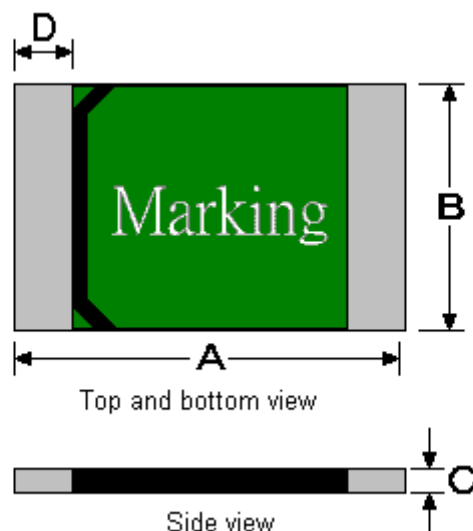

NOTE: Specifications subject to change without prior notice.

Pad Layouts and Soldering Reflow Recommendations

The dimension in the table below provide the recommended pad layout for each surface mount device

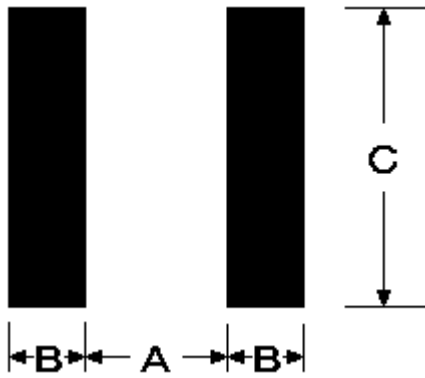

Pad dimensions(millimeters)			
Device	A Nominal	B Nominal	C Nominal
SL MODEL	5.10	2.30	5.60
SD MODEL	3.45	1.78	3.50
SM MODEL	2.00	1.00	2.80
SN MODEL	2.00	1.00	1.90

SOLDERING REFLOW (LEAD FREE)

- 1.Suggested reflow methods: IR, vapor phase oven, hot air oven.
- 2.Suitable for use with wave-soldering methods.
- 3.Recommended maximum paste thickness is 0.25mm.

CAUTION

If reflow temperatures exceed the recommended standard, devices may not be able to meet the performance requirements.

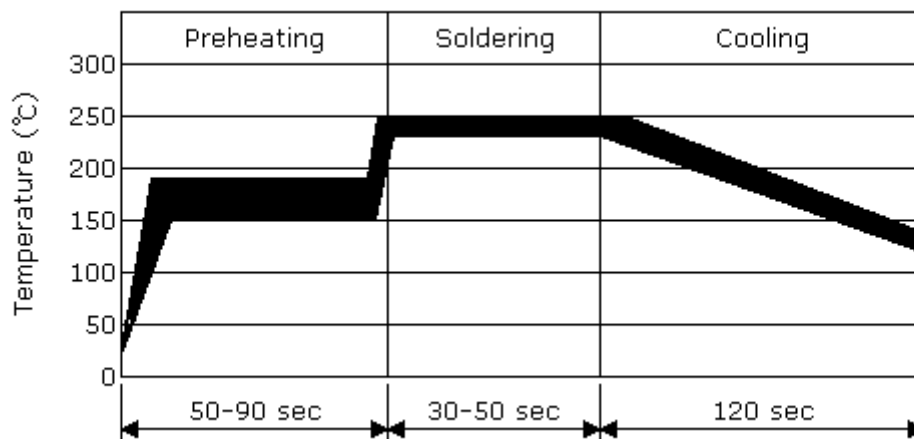

NOTE: Specifications subject to change without prior notice.