

LM828

Switched Capacitor Voltage Converter

General Description

The LM828 CMOS charge-pump voltage converter inverts a positive voltage in the range of +1.8V to +5.5V to the corresponding negative voltage of -1.8V to -5.5V. The LM828 uses two low cost capacitors to provide up to 25 mA of output current.

The LM828 operates at 12 kHz switching frequency to reduce output resistance and voltage ripple. With an operating current of only 40 μ A (operating efficiency greater than 96% with most loads), the LM828 provides ideal performance for battery powered systems. The device is in a tiny SOT-23-5 package.

Features

- Inverts Input Supply Voltage
- SOT-23-5 Package
- 20 Ω Typical Output Impedance
- 97% Typical Conversion Efficiency at 5 mA

Applications

- Cellular Phones
- Pagers
- PDAs
- Operational Amplifier Power Supplies
- Interface Power Supplies
- Handheld Instruments

Basic Application Circuits

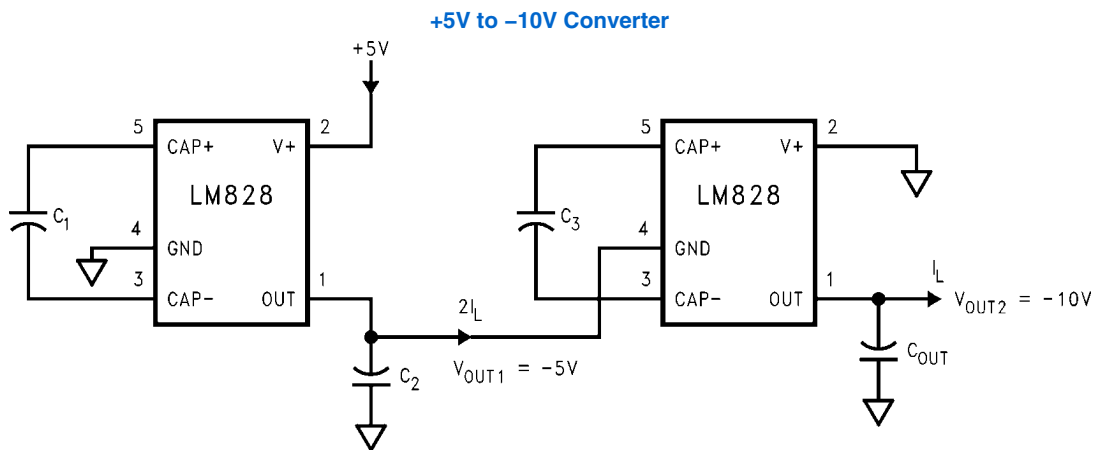
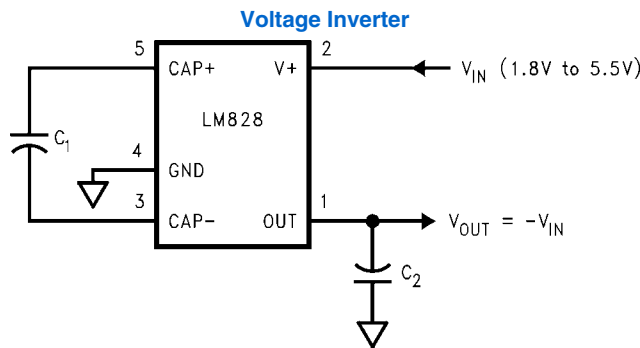

Absolute Maximum Ratings *(Note 1)*

If Military/Aerospace specified devices are required, please contact the National Semiconductor Sales Office/Distributors for availability and specifications.

Supply Voltage (V+ to GND, or GND to OUT)	5.8V
V+ and OUT Continuous Output Current	50 mA
Output Short-Circuit Duration to GND <i>(Note 2)</i>	1 sec.
Continuous Power Dissipation (T _A = 25°C) <i>(Note 3)</i>	240 mW

T _{JMax} <i>(Note 3)</i>	150°C
θ _{JA} <i>(Note 3)</i>	300°C/W
Operating Junction Temperature Range	-40°C to 85°C
Storage Temperature Range	-65°C to +150°C
Lead Temp. (Soldering, 10 seconds)	300°C
ESD Rating <i>(Note 7)</i>	2kV

Electrical Characteristics

Limits in standard typeface are for T_J = 25°C, and limits in **boldface** type apply over the full operating temperature range. Unless otherwise specified: V+ = 5V, C₁ = C₂ = 10 μF. *(Note 4)*

Symbol	Parameter	Condition	Min	Typ	Max	Units
V+	Supply Voltage	R _L = 10kΩ	1.8		5.5	V
I _Q	Supply Current	No Load		40	75 115	μA
R _{OUT}	Output Resistance <i>(Note 5)</i>	I _L = 5 mA		20	65	Ω
f _{OSC}	Oscillator Frequency <i>(Note 6)</i>	Internal	12	24	56	kHz
f _{SW}	Switching Frequency <i>(Note 6)</i>	Measured at CAP+	6	12	28	kHz
P _{EFF}	Power Efficiency	I _L = 5 mA		97		%
V _{OEFF}	Voltage Conversion Efficiency	No Load	95	99.96		%

Note 1: Absolute maximum ratings indicate limits beyond which damage to the device may occur. Electrical specifications do not apply when operating the device beyond its rated operating conditions.

Note 2: OUT may be shorted to GND for one second without damage. However, shorting OUT to V+ may damage the device and should be avoided. Also, for temperatures above 85°C, OUT must not be shorted to GND or V+, or the device may be damaged.

Note 3: The maximum allowable power dissipation is calculated by using P_{DMax} = (T_{JMax} - T_A)/θ_{JA}, where T_{JMax} is the maximum junction temperature, T_A is the ambient temperature, and θ_{JA} is the junction-to-ambient thermal resistance of the package.

Note 4: In the test circuit, capacitors C₁ and C₂ are 10 μF, 0.3Ω maximum ESR capacitors. Capacitors with higher ESR will increase output resistance, reduce output voltage and efficiency.

Note 5: Specified output resistance includes internal switch resistance and capacitor ESR. See the details in the application information.

Note 6: The output switches operate at one half of the oscillator frequency, f_{OSC} = 2f_{SW}.

Note 7: The human body model is a 100 pF capacitor discharged through a 1.5 kΩ resistor into each pin.

Test Circuit

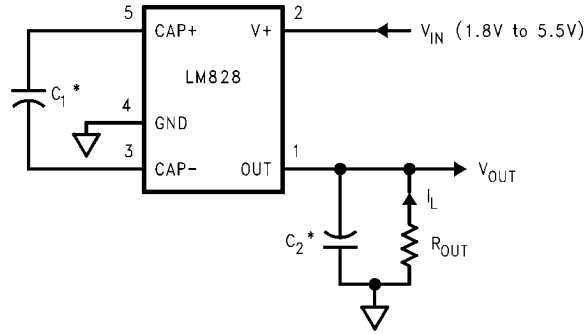

*C₁ and C₂ are 10 μF capacitors.

10013703

FIGURE 1. LM828 Test Circuit

Typical Performance Characteristics (Circuit of Figure 1, V₊ = 5V unless otherwise specified)

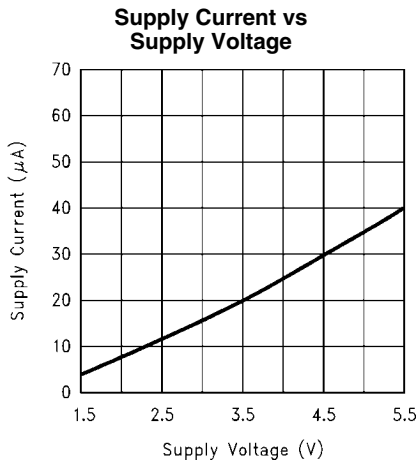

10013729

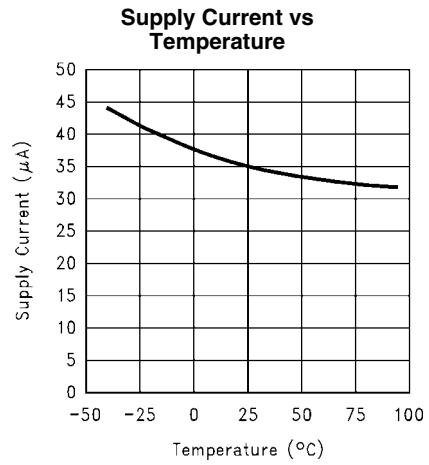

10013730

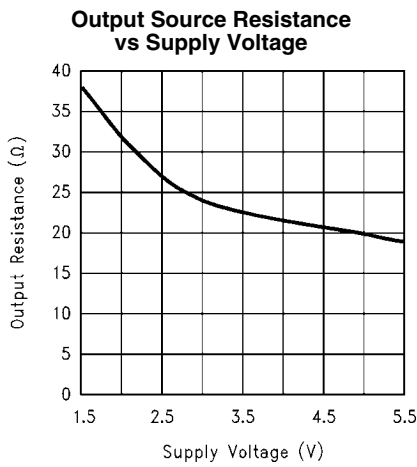

10013731

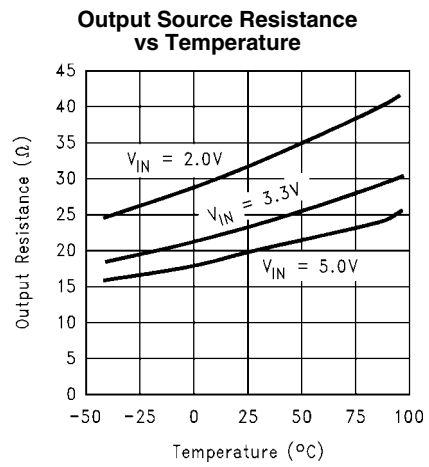

10013732

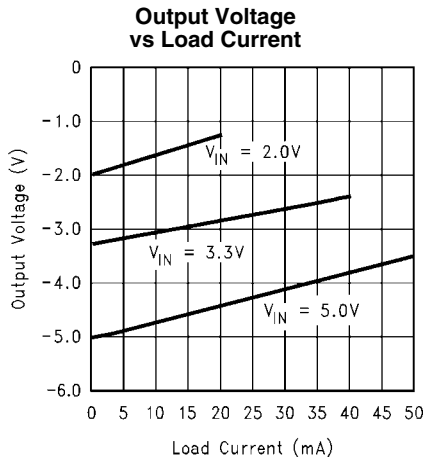

10013733

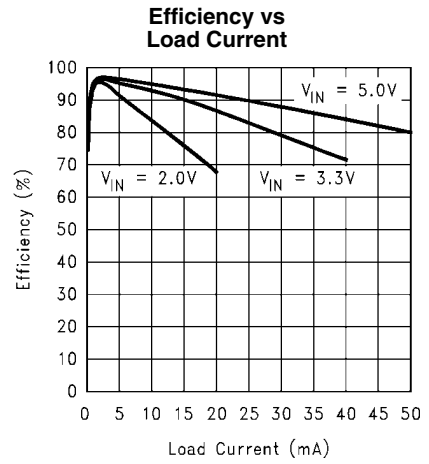

10013734

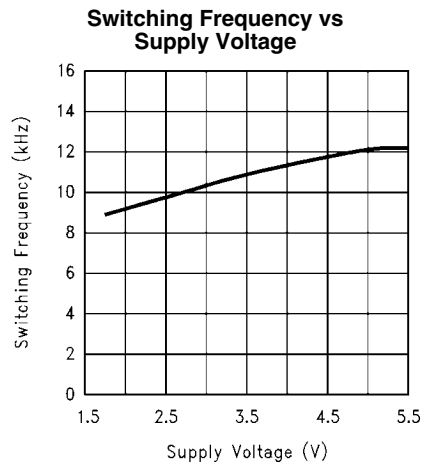

10013735

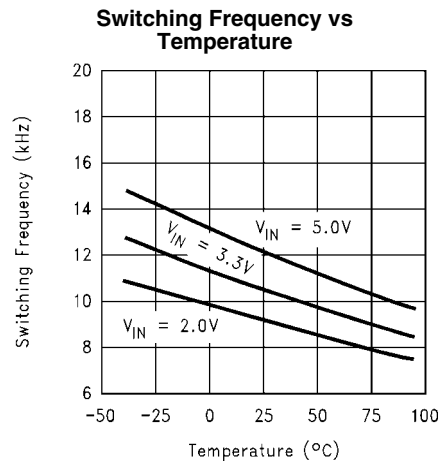

10013736

Connection Diagrams

5-Lead Small Outline Package (M5)

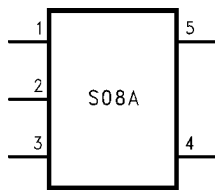

10013713

Top View With Package Marking



10013714

Actual Size

Ordering Information

Order Number	Package Number	Package Marking	Supplied as
LM828M5	MA05B	S08A (<i>Note 8</i>)	Tape and Reel (250 units/rail)
LM828M5X	MA05B	S08A (<i>Note 8</i>)	Tape and Reel (3000 units/rail)

Note 8: The first letter "S" identifies the part as a switched capacitor converter. The next two numbers are the device number. Larger quantity reels are available upon request.

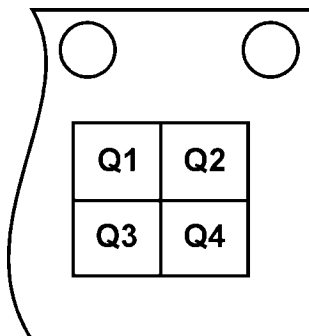

10013715

FIGURE 2.

Note 9: Pin 1 orientation is in quadrant Q2 as per Figure 2 above.

Pin Descriptions

Pin	Name	Function
1	OUT	Negative voltage output.
2	V+	Power supply positive input.
3	CAP-	Connect this pin to the negative terminal of the charge-pump capacitor.
4	GND	Power supply ground input.
5	CAP+	Connect this pin to the positive terminal of the charge-pump capacitor.

Circuit Description

The LM828 contains four large CMOS switches which are switched in a sequence to invert the input supply voltage. Energy transfer and storage are provided by external capacitors. *Figure 3* illustrates the voltage conversion scheme. When S_1 and S_3 are closed, C_1 charges to the supply voltage V_+ . During this time interval, switches S_2 and S_4 are open. In the second time interval, S_1 and S_3 are open; at the same time, S_2 and S_4 are closed, C_1 is charging C_2 . After a number of cycles, the voltage across C_2 will be pumped to V_+ . Since the anode of C_2 is connected to ground, the output at the cathode of C_2 equals $-(V_+)$ when there is no load current. The output voltage drop when a load is added is determined by the parasitic resistance ($R_{ds(on)}$ of the MOSFET switches and the ESR of the capacitors) and the charge transfer loss between capacitors.

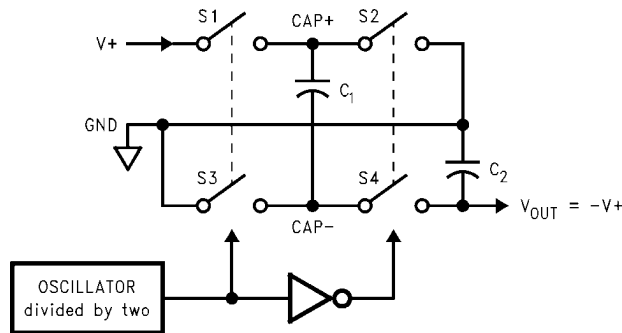

FIGURE 3. Voltage Inverting Principle

Application Information

SIMPLE NEGATIVE VOLTAGE CONVERTER

The main application of LM828 is to generate a negative supply voltage. The voltage inverter circuit uses only two external capacitors as shown in the Basic Application Circuits. The range of the input supply voltage is 1.8V to 5.5V.

The output characteristics of this circuit can be approximated by an ideal voltage source in series with a resistance. The voltage source equals $-(V_+)$. The output resistance, R_{out} , is a function of the ON resistance of the internal MOSFET switches, the oscillator frequency, the capacitance and the

ESR of both C_1 and C_2 . Since the switching current charging and discharging C_1 is approximately twice as the output current, the effect of the ESR of the pumping capacitor C_1 will be multiplied by four in the output resistance. The output capacitor C_2 is charging and discharging at a current approximately equal to the output current, therefore, this ESR term only counts once in the output resistance. A good approximation of R_{out} is:

$$R_{OUT} \cong 2R_{SW} + \frac{2}{f_{OSC} \times C_1} + 4ESR_{C1} + ESR_{C2}$$

where R_{SW} is the sum of the ON resistance of the internal MOSFET switches shown in *Figure 3*.

High capacitance, low ESR capacitors will reduce the output resistance.

The peak-to-peak output voltage ripple is determined by the oscillator frequency, the capacitance and ESR of the output capacitor C_2 :

$$V_{RIPPLE} = \frac{I_L}{f_{OSC} \times C_2} + 2 \times I_L \times ESR_{C2}$$

Again, using a low ESR capacitor will result in lower ripple.

CAPACITOR SELECTION

The output resistance and ripple voltage are dependent on the capacitance and ESR values of the external capacitors. The output voltage drop is the load current times the output resistance, and the power efficiency is

$$\eta = \frac{P_{OUT}}{P_{IN}} = \frac{I_L^2 R_L}{I_L^2 R_L + I_L^2 R_{OUT} + I_Q (V_+)}$$

Where $I_Q(V_+)$ is the quiescent power loss of the IC device, and $I_L^2 R_{out}$ is the conversion loss associated with the switch on-resistance, the two external capacitors and their ESRs.

The selection of capacitors is based on the specifications of the dropout voltage (which equals $I_{out} R_{out}$), the output voltage ripple, and the converter efficiency. Low ESR capacitors (following table) are recommended to maximize efficiency, reduce the output voltage drop and voltage ripple.

Low ESR Capacitor Manufacturers

Manufacturer	Phone	Capacitor Type
Nichicon Corp.	(708)-843-7500	PL & PF series, through-hole aluminum electrolytic
AVX Corp.	(803)-448-9411	TPS series, surface-mount tantalum
Sprague	(207)-324-4140	593D, 594D, 595D series, surface-mount tantalum
Sanyo	(619)-661-6835	OS-CON series, through-hole aluminum electrolytic
Murata	(800)-831-9172	Ceramic chip capacitors
Taiyo Yuden	(800)-348-2496	Ceramic chip capacitors
Token	(408)-432-8020	Ceramic chip capacitors

Other Applications

PARALLELING DEVICES

Any number of LM828s can be paralleled to reduce the output resistance. Each device must have its own pumping capacitor

C_1 , while only one output capacitor C_{out} is needed as shown in Figure 3. The composite output resistance is:

$$R_{OUT} = \frac{R_{OUT} \text{ of each LM828}}{\text{Number of Devices}}$$

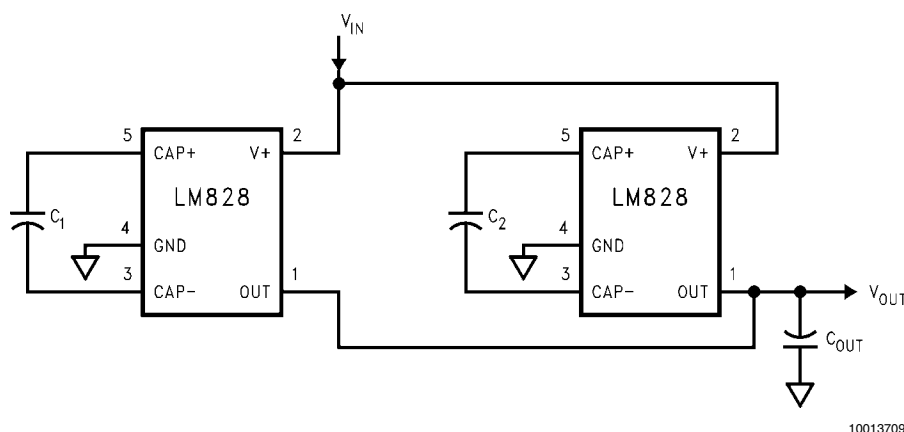

FIGURE 4. Lowering Output Resistance by Paralleling Devices

CASCADING DEVICES

Cascading the LM828s is an easy way to produce a greater negative voltage (e.g. A two-stage cascade circuit is shown in Figure 4).

If n is the integer representing the number of devices cascaded, the unloaded output voltage V_{out} is $(-nV_{in})$. The effective output resistance is equal to the weighted sum of each individual device:

$$R_{out} = nR_{out_1} + n/2 R_{out_2} + \dots + R_{out_n}$$

This can be seen by first assuming that each device is 100 percent efficient. Since the output voltage is different on each device the output current is as well. Each cascaded device sees less current at the output than the previous so the R_{OUT} voltage drop is lower in each device added. Note that, the number of n is practically limited since the increasing of n significantly reduces the efficiency, and increases the output resistance and output voltage ripple.

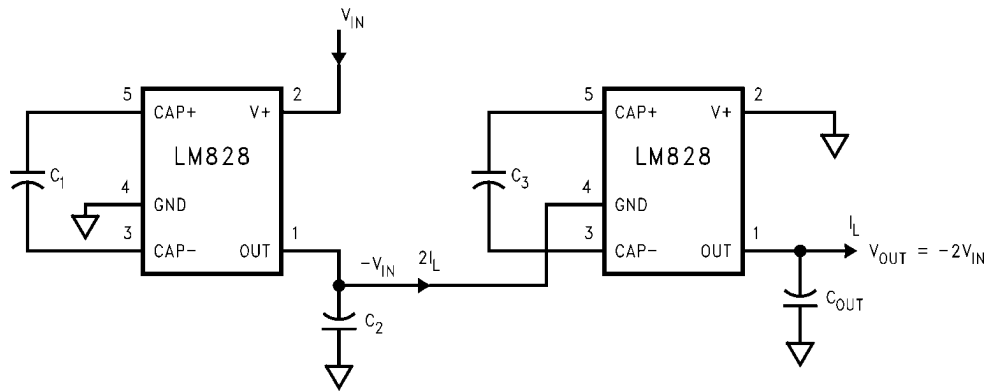

10013710

FIGURE 5. Increasing Output Voltage by Cascading Devices

COMBINED DOUBLER AND INVERTER

In Figure 5, the LM828 is used to provide a positive voltage doubler and a negative voltage converter. Note that the total current drawn from the two outputs should not exceed 40 mA.

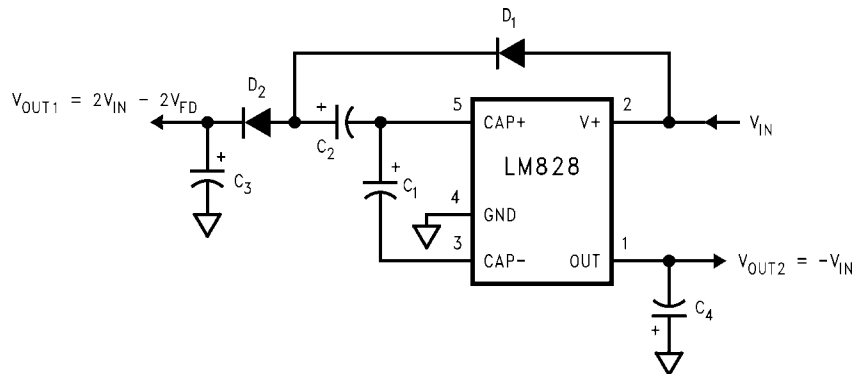

10013711

FIGURE 6. Combined Voltage Doubler and Inverter

REGULATING V_{OUT}

It is possible to regulate the negative output of the LM828 by use of a low dropout regulator (such as the LP2980). The whole converter is depicted in Figure 6. This converter can give a regulated output from $-1.8V$ to $-5.5V$ by choosing the proper resistor ratio:

$$V_{out} = V_{ref} (1 + R_1/R_2)$$

$$\text{where, } V_{ref} = 1.23V$$

Note that the following conditions must be satisfied simultaneously for worst case design:

$$V_{in_min} > V_{out_min} + V_{drop_max} (LP2980) + I_{out_max} \times R_{out_max} (LM828)$$

$$V_{in_max} < V_{out_max} + V_{drop_min} (LP2980) + I_{out_min} \times R_{out_min} (LM828)$$

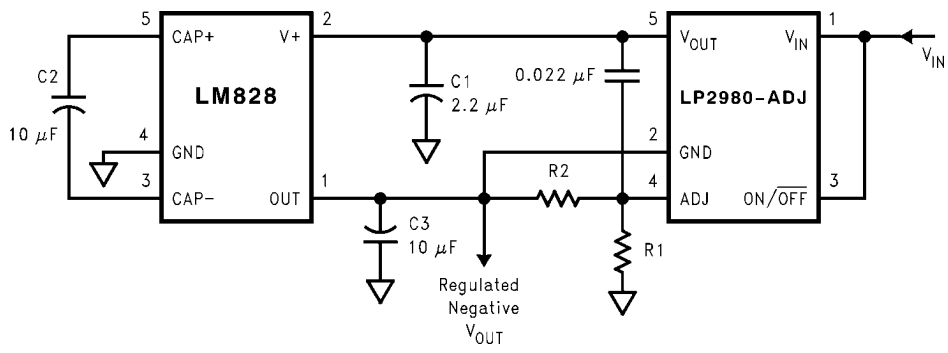

10013712

FIGURE 7. Combining LM828 with LP2980 to Make a Negative Adjustable Regulator

Physical Dimensions inches (millimeters) unless otherwise noted

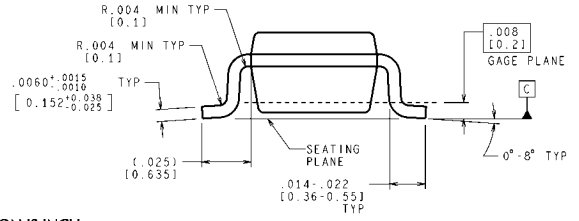
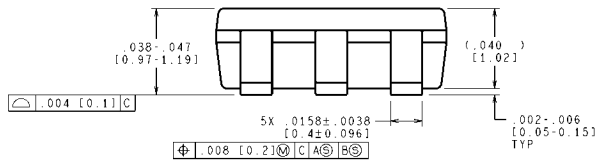
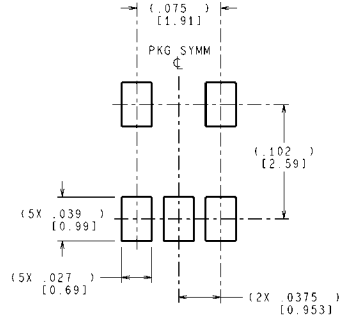
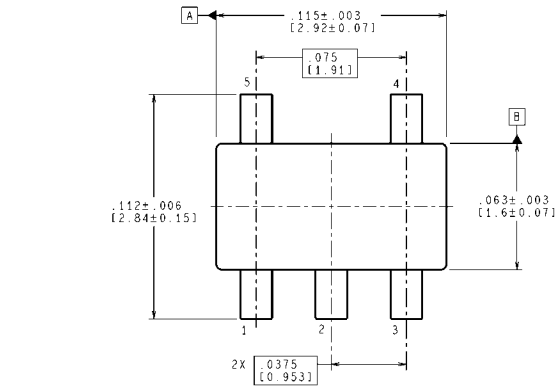

CONTROLLING DIMENSION IS INCH
 VALUES IN [] ARE MILLIMETERS
 DIMENSIONS IN () FOR REFERENCE ONLY

MF05A (Rev D)

**5-Lead Small Outline Package (M5)
 NS Package Number MF05A**

For Order Numbers, refer to the table in the "Ordering Information" section of this document.

Notes

LM828

Notes

For more National Semiconductor product information and proven design tools, visit the following Web sites at:
www.national.com

Products		Design Support	
Amplifiers	www.national.com/amplifiers	WEBENCH® Tools	www.national.com/webench
Audio	www.national.com/audio	App Notes	www.national.com/appnotes
Clock and Timing	www.national.com/timing	Reference Designs	www.national.com/refdesigns
Data Converters	www.national.com/adc	Samples	www.national.com/samples
Interface	www.national.com/interface	Eval Boards	www.national.com/evalboards
LVDS	www.national.com/lvds	Packaging	www.national.com/packaging
Power Management	www.national.com/power	Green Compliance	www.national.com/quality/green
Switching Regulators	www.national.com/switchers	Distributors	www.national.com/contacts
LDOs	www.national.com/ldo	Quality and Reliability	www.national.com/quality
LED Lighting	www.national.com/led	Feedback/Support	www.national.com/feedback
Voltage References	www.national.com/vref	Design Made Easy	www.national.com/easy
PowerWise® Solutions	www.national.com/powerwise	Applications & Markets	www.national.com/solutions
Serial Digital Interface (SDI)	www.national.com/sdi	Mil/Aero	www.national.com/milaero
Temperature Sensors	www.national.com/tempensors	SolarMagic™	www.national.com/solarmagic
PLL/VCO	www.national.com/wireless	PowerWise® Design University	www.national.com/training

THE CONTENTS OF THIS DOCUMENT ARE PROVIDED IN CONNECTION WITH NATIONAL SEMICONDUCTOR CORPORATION ("NATIONAL") PRODUCTS. NATIONAL MAKES NO REPRESENTATIONS OR WARRANTIES WITH RESPECT TO THE ACCURACY OR COMPLETENESS OF THE CONTENTS OF THIS PUBLICATION AND RESERVES THE RIGHT TO MAKE CHANGES TO SPECIFICATIONS AND PRODUCT DESCRIPTIONS AT ANY TIME WITHOUT NOTICE. NO LICENSE, WHETHER EXPRESS, IMPLIED, ARISING BY ESTOPPEL OR OTHERWISE, TO ANY INTELLECTUAL PROPERTY RIGHTS IS GRANTED BY THIS DOCUMENT.

TESTING AND OTHER QUALITY CONTROLS ARE USED TO THE EXTENT NATIONAL DEEMS NECESSARY TO SUPPORT NATIONAL'S PRODUCT WARRANTY. EXCEPT WHERE MANDATED BY GOVERNMENT REQUIREMENTS, TESTING OF ALL PARAMETERS OF EACH PRODUCT IS NOT NECESSARILY PERFORMED. NATIONAL ASSUMES NO LIABILITY FOR APPLICATIONS ASSISTANCE OR BUYER PRODUCT DESIGN. BUYERS ARE RESPONSIBLE FOR THEIR PRODUCTS AND APPLICATIONS USING NATIONAL COMPONENTS. PRIOR TO USING OR DISTRIBUTING ANY PRODUCTS THAT INCLUDE NATIONAL COMPONENTS, BUYERS SHOULD PROVIDE ADEQUATE DESIGN, TESTING AND OPERATING SAFEGUARDS.

EXCEPT AS PROVIDED IN NATIONAL'S TERMS AND CONDITIONS OF SALE FOR SUCH PRODUCTS, NATIONAL ASSUMES NO LIABILITY WHATSOEVER, AND NATIONAL DISCLAIMS ANY EXPRESS OR IMPLIED WARRANTY RELATING TO THE SALE AND/OR USE OF NATIONAL PRODUCTS INCLUDING LIABILITY OR WARRANTIES RELATING TO FITNESS FOR A PARTICULAR PURPOSE, MERCHANTABILITY, OR INFRINGEMENT OF ANY PATENT, COPYRIGHT OR OTHER INTELLECTUAL PROPERTY RIGHT.

LIFE SUPPORT POLICY

NATIONAL'S PRODUCTS ARE NOT AUTHORIZED FOR USE AS CRITICAL COMPONENTS IN LIFE SUPPORT DEVICES OR SYSTEMS WITHOUT THE EXPRESS PRIOR WRITTEN APPROVAL OF THE CHIEF EXECUTIVE OFFICER AND GENERAL COUNSEL OF NATIONAL SEMICONDUCTOR CORPORATION. As used herein:

Life support devices or systems are devices which (a) are intended for surgical implant into the body, or (b) support or sustain life and whose failure to perform when properly used in accordance with instructions for use provided in the labeling can be reasonably expected to result in a significant injury to the user. A critical component is any component in a life support device or system whose failure to perform can be reasonably expected to cause the failure of the life support device or system or to affect its safety or effectiveness.

National Semiconductor and the National Semiconductor logo are registered trademarks of National Semiconductor Corporation. All other brand or product names may be trademarks or registered trademarks of their respective holders.

Copyright© 2010 National Semiconductor Corporation

For the most current product information visit us at www.national.com



National Semiconductor
Americas Technical
Support Center
Email: support@nsc.com
Tel: 1-800-272-9959

National Semiconductor Europe
Technical Support Center
Email: europe.support@nsc.com

National Semiconductor Asia
Pacific Technical Support Center
Email: ap.support@nsc.com

National Semiconductor Japan
Technical Support Center
Email: jpn.feedback@nsc.com