

DM74LS75 Quad Latch

General Description

These latches are ideally suited for use as temporary storage for binary information between processing units and input/output or indicator units. Information present at a data (D) input is transferred to the Q output when the enable is HIGH, and the Q output will follow the data input as long as the enable remains HIGH. When the enable goes LOW, the information (that was present at the data input at the time the transition occurred) is retained at the Q output until the enable is permitted to go HIGH.

These latches feature complementary Q and \bar{Q} outputs from a 4-bit latch, and are available in 16-pin packages.

Ordering Code:

Order Number	Package Number	Package Description
DM74LS75M	M16A	16-Lead Small Outline Integrated Circuit (SOIC), JEDEC MS-012, 0.150 Narrow
DM74LS75N	N16E	16-Lead Plastic Dual-In-Line Package (PDIP), JEDEC MS-001, 0.300 Wide

Devices also available in Tape and Reel. Specify by appending the suffix letter "X" to the ordering code.

Logic Diagram

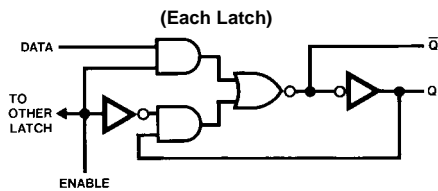

Connection Diagram

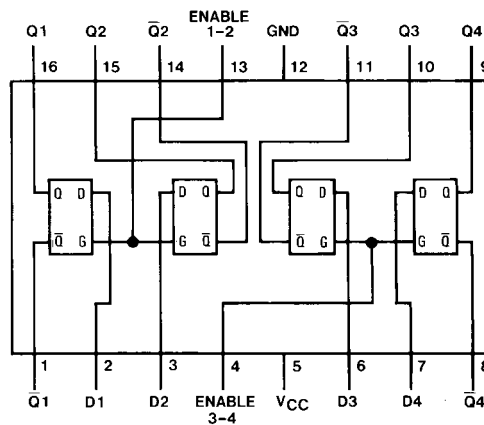

Function Table (Each Latch)

Inputs		Outputs	
D	Enable	Q	\bar{Q}
L	H	L	H
H	H	H	L
X	L	Q_0	\bar{Q}_0

H = HIGH Level
L = LOW Level
X = Don't Care
 Q_0 = The Level of Q Before the HIGH-to-LOW Transition of ENABLE

Absolute Maximum Ratings(Note 1)

Supply Voltage	7V
Input Voltage	7V
Operating Free Air Temperature Range	0°C to +70°C
Storage Temperature Range	-65°C to +150°C

Note 1: The "Absolute Maximum Ratings" are those values beyond which the safety of the device cannot be guaranteed. The device should not be operated at these limits. The parametric values defined in the Electrical Characteristics tables are not guaranteed at the absolute maximum ratings. The "Recommended Operating Conditions" table will define the conditions for actual device operation.

Recommended Operating Conditions

Symbol	Parameter	Min	Nom	Max	Units
V_{CC}	Supply Voltage	4.75	5	5.25	V
V_{IH}	HIGH Level Input Voltage	2			V
V_{IL}	LOW Level Input Voltage			0.8	V
I_{OH}	HIGH Level Output Current			-0.4	mA
I_{OL}	LOW Level Output Current			8	mA
t_W	Enable Pulse Width (Note 5)	20			ns
t_{SU}	Setup Time (Note 5)	20			ns
t_H	Hold Time (Note 5)	0			ns
T_A	Free Air Operating Temperature	0		70	°C

Electrical Characteristics

over recommended operating free air temperature range (unless otherwise noted)

Symbol	Parameter	Conditions	Min	Typ (Note 2)	Max	Units
V_I	Input Clamp Voltage	$V_{CC} = \text{Min}, I_I = -18 \text{ mA}$			-1.5	V
V_{OH}	HIGH Level Output Voltage	$V_{CC} = \text{Min}, I_{OH} = \text{Max}$ $V_{IL} = \text{Max}, V_{IH} = \text{Min}$	2.7	3.5		V
V_{OL}	LOW Level Output Voltage	$V_{CC} = \text{Min}, I_{OL} = \text{Max}$ $V_{IL} = \text{Max}, V_{IH} = \text{Min}$ $I_{OL} = 4 \text{ mA}, V_{CC} = \text{Min}$		0.35	0.5	V
I_I	Input Current @ Max Input Voltage	$V_{CC} = \text{Max}, V_I = 7V$	D		0.1	mA
			Enable		0.4	
I_{IH}	HIGH Level Input Current	$V_{CC} = \text{Max}, V_I = 2.7V$	D		20	μA
			Enable		80	
I_{IL}	LOW Level Input Current	$V_{CC} = \text{Max}, V_I = 0.4V$	D		-0.4	mA
			Enable		-1.6	
I_{OS}	Short Circuit Output Current	$V_{CC} = \text{Max}$ (Note 2)	-20		-100	mA
I_{CC}	Supply Current	$V_{CC} = \text{Max}$ (Note 3)		6.3	12	mA

Note 2: All typicals are at $V_{CC} = 5V, T_A = 25^\circ\text{C}$.

Note 3: Not more than one output should be shorted at a time, and the duration should not exceed one second.

Note 4: I_{CC} is measured with all outputs open and all inputs grounded.

Note 5: $T_A = 25^\circ\text{C}$ and $V_{CC} = 5V$.

Switching Characteristics

at $V_{CC} = 5V$ and $T_A = 25^\circ C$

Symbol	Parameter	From (Input) To (Output)	$R_L = 2\text{ k}\Omega$				Units
			$C_L = 15\text{ pF}$		$C_L = 50\text{ pF}$		
			Min	Max	Min	Max	
t_{PLH}	Propagation Delay Time LOW-to-HIGH Level Output	D to Q		27		30	ns
t_{PHL}	Propagation Delay Time HIGH-to-LOW Level Output	D to Q		17		25	ns
t_{PLH}	Propagation Delay Time LOW-to-HIGH Level Output	D to \bar{Q}		20		25	ns
t_{PHL}	Propagation Delay Time HIGH-to-LOW Level Output	D to \bar{Q}		15		20	ns
t_{PLH}	Propagation Delay Time LOW-to-HIGH Level Output	Enable to Q		27		30	ns
t_{PHL}	Propagation Delay Time HIGH-to-LOW Level Output	Enable to Q		25		30	ns
t_{PLH}	Propagation Delay Time LOW-to-HIGH Level Output	Enable to \bar{Q}		30		30	ns
t_{PHL}	Propagation Delay Time HIGH-to-LOW Level Output	Enable to \bar{Q}		15		20	ns

Physical Dimensions inches (millimeters) unless otherwise noted

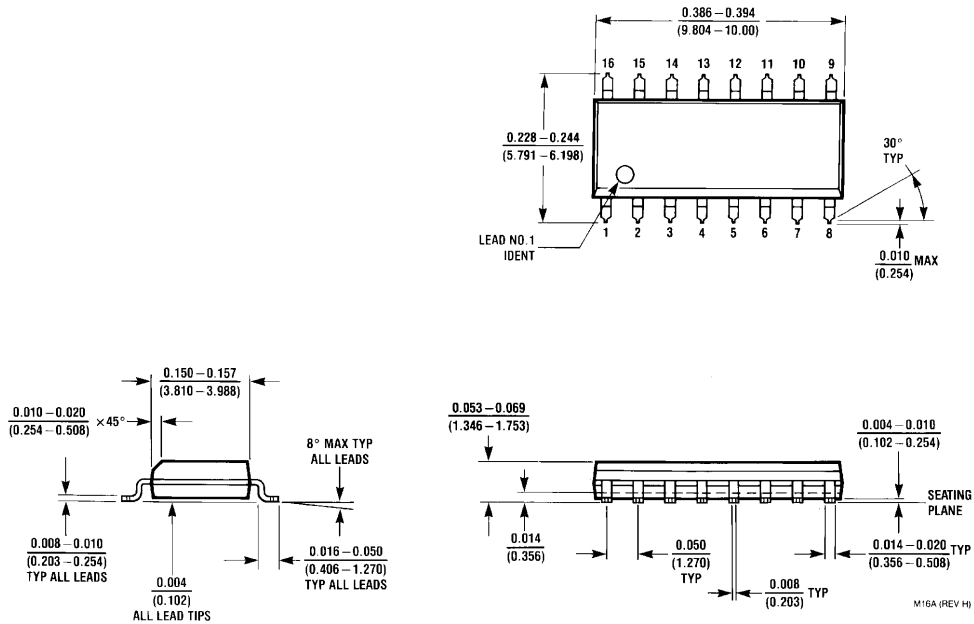

**16-Lead Small Outline Integrated Circuit (SOIC), JEDEC MS-012, 0.150 Narrow
Package Number M16A**

M16A (REV H)

Physical Dimensions inches (millimeters) unless otherwise noted (Continued)

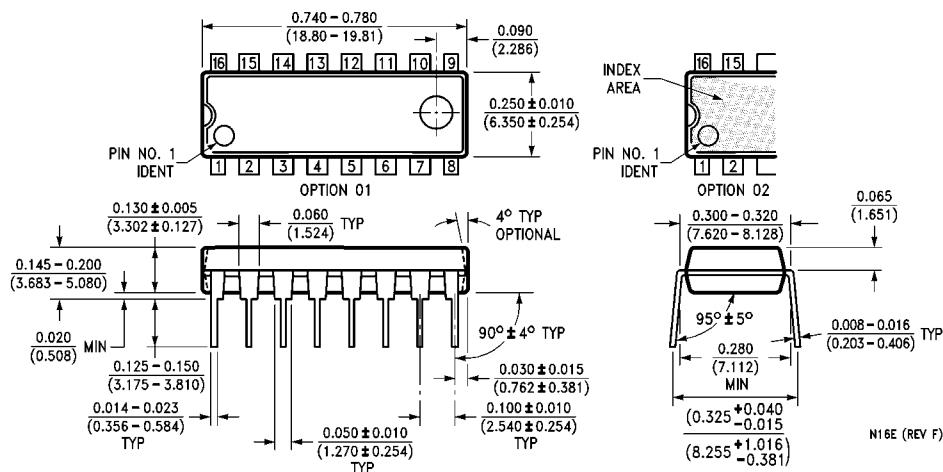

16-Lead Plastic Dual-In-Line Package (PDIP), JEDEC MS-001, 0.300 Wide Package Number N16E

Fairchild does not assume any responsibility for use of any circuitry described, no circuit patent licenses are implied and Fairchild reserves the right at any time without notice to change said circuitry and specifications.

LIFE SUPPORT POLICY

FAIRCHILD'S PRODUCTS ARE NOT AUTHORIZED FOR USE AS CRITICAL COMPONENTS IN LIFE SUPPORT DEVICES OR SYSTEMS WITHOUT THE EXPRESS WRITTEN APPROVAL OF THE PRESIDENT OF FAIRCHILD SEMICONDUCTOR CORPORATION. As used herein:

1. Life support devices or systems are devices or systems which, (a) are intended for surgical implant into the body, or (b) support or sustain life, and (c) whose failure to perform when properly used in accordance with instructions for use provided in the labeling, can be reasonably expected to result in a significant injury to the user.
2. A critical component in any component of a life support device or system whose failure to perform can be reasonably expected to cause the failure of the life support device or system, or to affect its safety or effectiveness.

www.fairchildsemi.com