

PAL CHROMINANCE SIGNAL PROCESSOR FOR VIDEO RECORDERS

GENERAL DESCRIPTION

The TDA3760 is a monolithic integrated circuit for chrominance signal processing in video recorders.

Features

- Automatic gain controlled pre-amplifier with record/playback selection
- Signal mixer with balancing stage
- Output stage for the 627 kHz chrominance signal, with facility for being disabled by colour killer and record/playback mode switch
- Amplitude detector with automatic gain control for the preamplifier
- 4,43 MHz voltage controlled oscillator (VCO) for recording and playback
- 4,43 MHz fixed oscillator for playback
- Phase detector controlled synchronization of the VCO
- Subcarrier mixer
- H/2 demodulator for the production of PAL identification and colour killing signals
- Flip-flop for PAL identification
- Sandcastle pulse processing
- Colour killing stage with hysteresis
- Internal record/playback selection
- Second phase detector for fast phase correction of sub-carrier

QUICK REFERENCE DATA

Supply voltage (pin 9)	$V_P = V_{9-15}$	typ.	10 V
Supply current (pin 9)	$I_P = I_9$	typ.	45 mA
Inputs			
Chrominance signal			
4,43 MHz for record (peak-to-peak value)	$V_{2-15(p-p)}$	typ.	200 mV
627 kHz for playback (peak-to-peak value)	$V_{1-15(p-p)}$	typ.	200 mV
Outputs			
Chrominance signal			
4,43 MHz (peak-to-peak value)	$V_{24-15(p-p)}$	typ.	490 mV
627 kHz (peak-to-peak value)	$V_{26-15(p-p)}$	typ.	2 V

PACKAGE OUTLINE

28-lead DIL; plastic (SOT117).

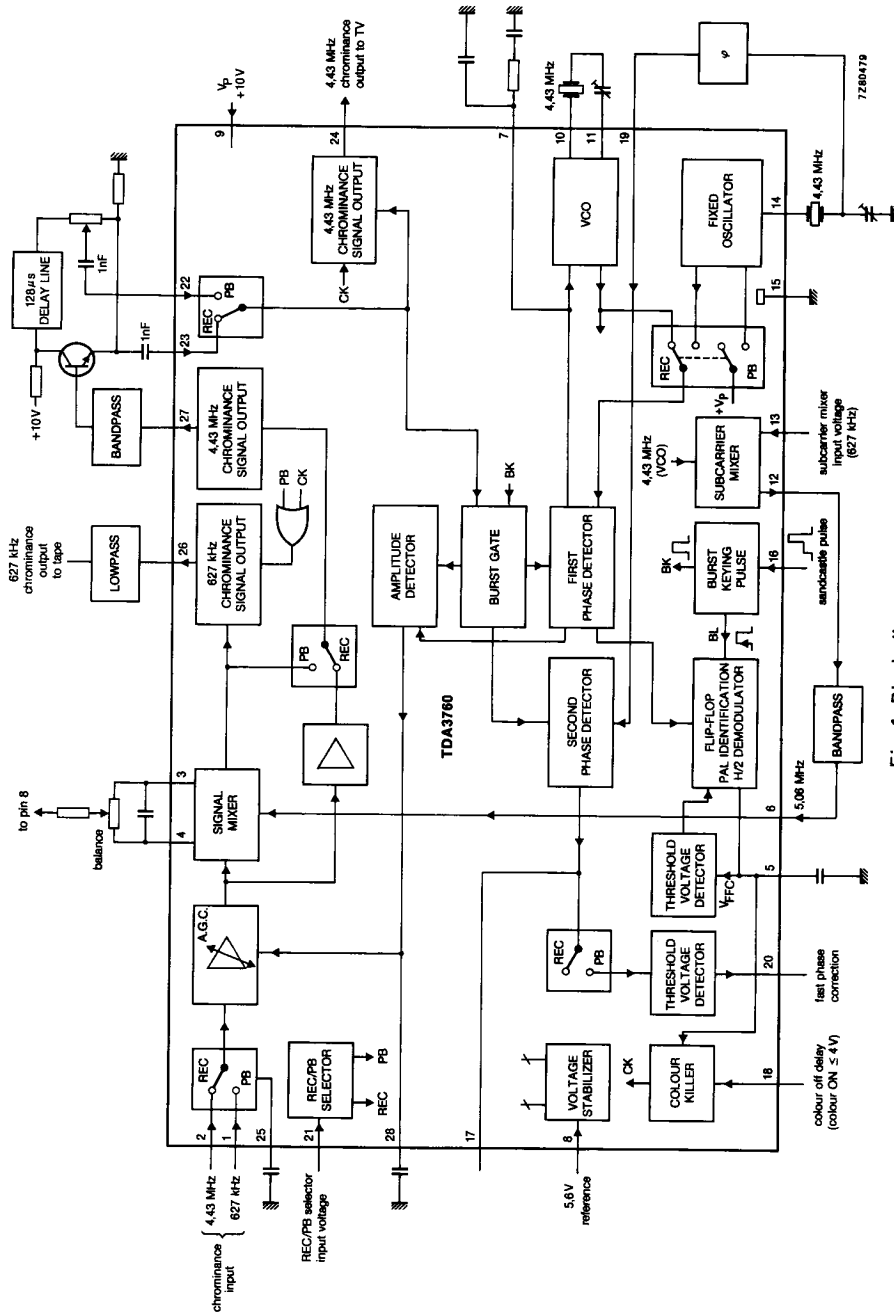

Fig. 1 Block diagram.

- BK = burst key pulse
- BL = blanking pulse
- FFC = flip-flop correction
- FPC = fast phase correction
- REC = record
- PB = playback
- CK = colour killer

RATINGS

Limiting values in accordance with the Absolute Maximum System (IEC 134)

Supply voltage (pin 9)	$V_P = V_{9-15}$	max.	13,2 V
Voltage range at pins 1, 2, 5, 7, 8, 9, 16, 17, 18, 19, 20, 21, 22, 23 to pin 15 (ground)	V_{n-15}		0 to V_P V
Voltage ranges			
at pins 3, 4, 28*	$V_{3, 4, 28-15}$		3 to 6 V
at pin 6, 25*	$V_{6, 25-15}$		0 to 5 V
at pin 10*	V_{10-15}		1,5 to 4 V
at pin 13*	V_{13-15}		0 to 3 V
at pin 14*	V_{14-15}		0 to 8 V
Voltages			
at pin 12	V_{12-15}	max.	V_P V
at pin 24	V_{24-15}	max.	7 V
Currents			
at pins 11, 18	$-I_{11, 18}$	max.	2 mA
at pins 12, 26, 27	$-I_{12, 26, 27}$	max.	5 mA
at pin 24	$-I_{24}$	max.	3 mA
Total power dissipation	P_{tot}	max.	1,4 W
Storage temperature range	T_{stg}		-25 to +150 °C
Operating ambient temperature range	T_{amb}		0 to +70 °C

* Measured with $V_{8-15} = 5,6$ V

CHARACTERISTICS

$V_P = V_{9-15} = 10 \text{ V}$; $V_{8-15} = 5,6 \text{ V}$; $T_{\text{amb}} = 25 \text{ }^\circ\text{C}$; burst key duration $4 \mu\text{s}$; unless otherwise specified

parameter	symbol	min.	typ.	max.	unit
Supply (pin 9)					
Supply voltage	$V_P = V_{9-15}$	9,6	—	13,2	V
Supply current for playback and burst keying at $-I_{12, 18, 24, 26, 27} = 0$	$I_P = I_9$	—	45	—	mA
at $-I_{12, 18, 24, 26, 27} = 0$; $V_P = 12 \text{ V}$	$I_P = I_9$	—	46	—	mA
A.G.C. preamplifier (pins 1 and 2)					
Input voltage* (f = 4,43 MHz) during record (peak-to-peak value)	$V_{2-15(p-p)}$	20	—	400	mV
Input voltage* (f = 627 kHz) during playback (peak-to-peak value)	$V_{1-15(p-p)}$	30	—	400	mV
Input resistance	$R_{1, 2-15}$	7	—	—	k Ω
Input capacitance	$C_{1, 2-15}$	—	—	5	pF
627 kHz chrominance signal (pin 26)* (transposed on to 627 kHz signal)					
Output voltage (peak-to-peak value)	$V_{26-15(p-p)}$	—	2	—	V
Signal suppression at output for f = 1,25 MHz	α_{26}	—	35	—	dB
for f = 5,06 MHz (externally balanced via pins 3 and 4)	α_{26}	—	40	—	dB
during colour killing (pin 25)	α_{26}	40	—	—	dB
D.C. output voltage	V_{26-15}	—	6,7	—	V
4,43 MHz chrominance signal (pin 27)*					
Output voltage during record (peak-to-peak value)	$V_{27-15(p-p)}$	—	1,15	—	V
during playback after signal mixing (peak-to-peak value)	$V_{27-15(p-p)}$	—	—	3,1	V
Signal suppression at output for f = 5,06 MHz (externally balanced)	α_{27}	—	40	—	dB
for f = 8,86 MHz	α_{27}	—	30	—	dB
for f = 3,81 MHz	α_{27}	—	38	—	dB
for f = 3,18 MHz	α_{27}	—	30	—	dB
D.C. output voltage	V_{27-15}	—	7	—	V

* The chrominance signal values hold for a 75% saturated colour bar signal.

parameter	signal	min.	typ.	max.	unit
4,43 MHz chrominance signal amplifier*					
Burst input signal					
at pin 22 (peak-to-peak value)	V _{22-15(p-p)}	—	225	—	mV
at pin 23 (peak-to-peak value)	V _{23-15(p-p)}	—	225	—	mV
Input resistance					
at pin 22	R ₂₂₋₁₅	6	—	—	kΩ
at pin 23	R ₂₃₋₁₅	6	—	—	kΩ
Output voltage of the chrominance signal					
at pin 24 (peak-to-peak value)	V _{24-15(p-p)}	—	490	—	mV
Signal suppression at output (pin 24)					
during colour killing	α ₂₄	35	—	—	dB
D.C. output voltage					
during colour-on	V ₂₄₋₁₅	—	2,4	—	V
during colour-off (killed)	V ₂₄₋₁₅	—	0,7	—	V
Subcarrier mixer					
627 kHz input voltage; sine-wave					
(peak-to-peak value)	V _{13-15(p-p)}	220	—	—	mV
Input resistance	R ₁₃₋₁₅	1	—	—	kΩ
D.C. output voltage	V ₁₂₋₁₅	—	7,9	—	V
5,06 MHz output voltage selective**					
(peak-to-peak value)	V _{12-15(p-p)}	—	800	—	mV
Signal suppression at output**					
for f = 4,43 MHz	α ₁₂	20	—	—	dB
for f = 5,68 MHz	α ₁₂	30	—	—	dB
Subcarrier input					
5,06 MHz input voltage (peak-to-peak value)	V _{6-15(p-p)}	250	—	—	mV
Input resistance	R ₆₋₁₅	1,9	—	—	kΩ
Input capacitance	C ₆₋₁₅	—	—	5	pF

* Chrominance signal values hold for a 75% saturated colour bar signal.

** Measured with a 0,32 V (peak-to-peak), 627 kHz input signal on pin 13 ($-I_{12} = 1$ mA).

CHARACTERISTICS (continued)

parameter	symbol	min.	typ.	max.	unit
4,43 MHz voltage controlled oscillator (VCO)					
Input resistance	R ₁₀₋₁₅	—	430	—	Ω
Input capacitance	C ₁₀₋₁₅	—	—	10	pF
Output resistance	R ₁₁₋₁₅	—	—	200	Ω
PLL-controlled oscillator catching range	Δf	± 500	—	—	Hz
Phase difference between oscillator and burst signal for ± 400 Hz deviation of crystal frequency	φ	± 7	—	—	deg
4,43 MHz fixed oscillator					
Oscillator temperature coefficient*	TC	—	—	-3	Hz/K
Record/playback selector (pin 21)					
Input voltage for record**	V ₂₁₋₁₅	—	—	4	V
Input current with V ₂₁₋₁₅ = 4 V	I ₂₁	—	—	130	μA
Input voltage for playback	V ₂₁₋₁₅	8	—	—	V
Input current with V ₂₁₋₁₅ = 8 V	I ₂₁	—	—	430	μA
Input resistance	R ₂₁₋₁₅	7	—	—	kΩ
Colour (on/off) killer delay					
Delay for chrominance signal OFF at ΔV = 1 V; C = 1 μF; PNP emitter follower with internal current of 0,1 mA	t _d	—	10	—	ms
Input voltage (pin 18) for forced colour ON	V ₁₈₋₁₅	—	—	4	V
for forced colour OFF	V ₁₈₋₁₅	5,5	—	9	V
Voltage stabilizer (pin 8)					
Range of external reference voltage	V ₈₋₁₅	5,3	—	5,8	V
Input current	-I ₈	—	—	120	μA

* Not considering the effects of external components.

** Pin open: record.

parameter	symbol	min.	typ.	max.	unit
Sandcastle pulse input (pin 16)					
Input voltage for burst keying	V ₁₆₋₁₅	7,1	—	—	V
Input current	I ₁₆	—	—	5	μA
Delay time of BK	t _d	—	0,55	—	μs
Input voltage for triggering of flip-flop	V ₁₆₋₁₅	2	—	—	V
Fast phase correction					
Input voltage* (peak-to-peak value)	V _{19-15(p-p)}	200	—	400	mV
Input resistance	R ₁₉₋₁₅	3,3	—	—	kΩ
Output voltage					
<i>without correction</i>					
below phase differences of ± 50° at I ₂₀ < ± 20 μA and V ₁₇₋₁₅ < 6,5 V	V ₂₀₋₁₅	—	—	5,2	V
<i>with correction</i>					
above phase differences of ± 65° at I ₂₀ < ± 20 μA and V ₁₇₋₁₅ > 7,1 V	V ₂₀₋₁₅	9	—	—	V
Output resistance	R ₂₀₋₁₅	—	35	—	kΩ

* Phase difference between output pin 14 and input pin 19 should be $\varphi = 90^\circ$.

APPLICATION INFORMATION

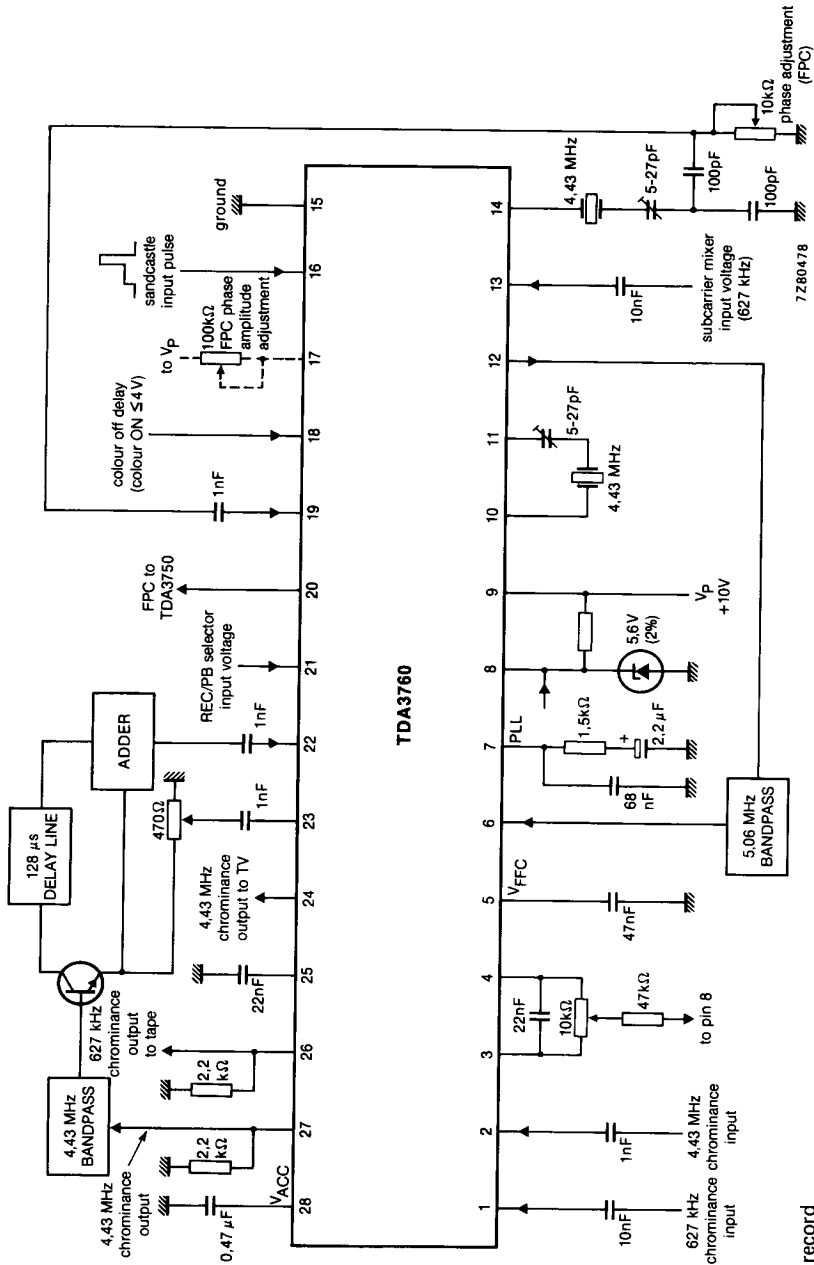

REC = record
 PB = playback
 FPC = fast phase correction
 FFC = flip-flop correction

Fig. 2 Application diagram.