

# OKI semiconductor

## MSM6242RS/GS

### DIRECT BUS CONNECTED CMOS REAL TIME CLOCK/CALENDAR

#### GENERAL DESCRIPTION

The MSM6242 is a silicon gate CMOS Real Time Clock/Calendar for use in direct bus-connection Microprocessor/Microcomputer applications. An on-chip 32.768KHz crystal oscillator time base is divided to provide addressable 4-bit I/O data for SECONDS, MINUTES, HOURS, DAY OF WEEK, DATE, MONTH and YEAR. Data access is controlled by 4-bit address, chip selects ( $\overline{CS0}$ ,  $\overline{CS1}$ ),  $\overline{WRITE}$ ,  $\overline{READ}$ , and ALE. Control Registers D, E and F provide for 30 SECOND error adjustment, INTERRUPT REQUEST (IRQ FLAG) and BUSY status bits, clock STOP, HOLD, and RESET FLAG bits, 4 selectable INTERRUPTS rates are available at the STD.P (STANDARD PULSE) output utilizing Control Register inputs T0, T1 and the ITRPT/STND (INTERRUPT/STANDARD). Masking of the interrupt output (STD.P) can be accomplished via the MASK bit. The MSM6242 can operate in a 12/24 hour format and Leap Year timing is automatic.

The MSM6242 normally operates from a  $5V \pm 10\%$  supply at  $-30$  to  $85^\circ\text{C}$ . Battery backup operation down to 2.0V allows continuation of time keeping when main power is off. The MSM6242 is offered in a 18-pin plastic DIP package.

#### FEATURES

##### DIRECT MICROPROCESSOR/MICROCONTROLLER BUS CONNE

TIME	MONTH	DATE	YEAR	DAY OF WEEK
23:59:59	12	31	80	7

- 4-bit data bus
- 4-bit address bus
- $\overline{READ}$ ,  $\overline{WRITE}$ , ALE and CHIP SELECT INPUTS
- Status registers – IRQ and BUSY
- Selectable interrupt outputs – 1/64 second, 1 second, 1 minute, 1 hour
- Interrupt masking
- 32.768KHz crystal controlled operation
- 12/24 hour format
- Auto leap year
- $\pm 30$  second error correction
- Single 5V supply
- Battery backup down to  $V_{DD} = 2.0V$
- Low power dissipation:
  - 20  $\mu\text{W}$  max at  $V_{DD} = 2V$
  - 150  $\mu\text{W}$  max at  $V_{DD} = 5V$
- 18-pin plastic DIP package

#### FUNCTIONAL BLOCK DIAGRAM

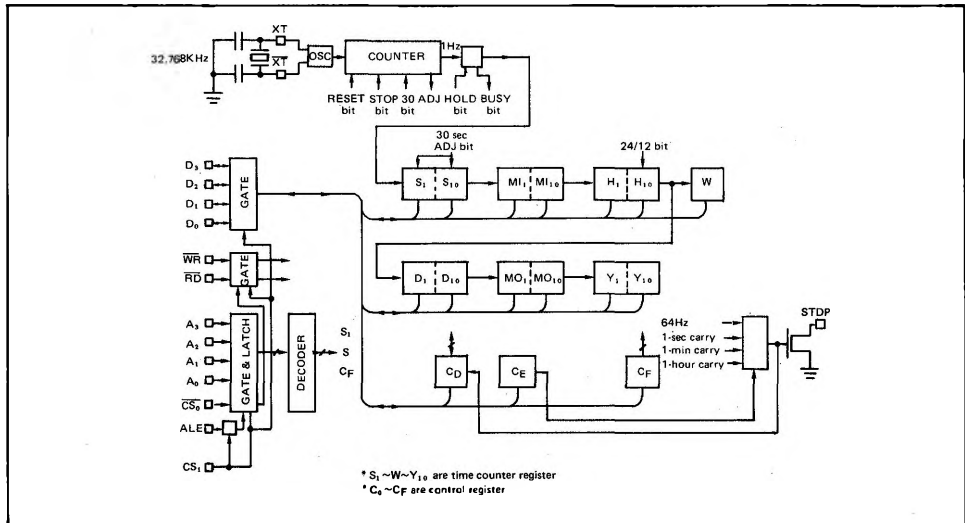

**PIN CONFIGURATION**

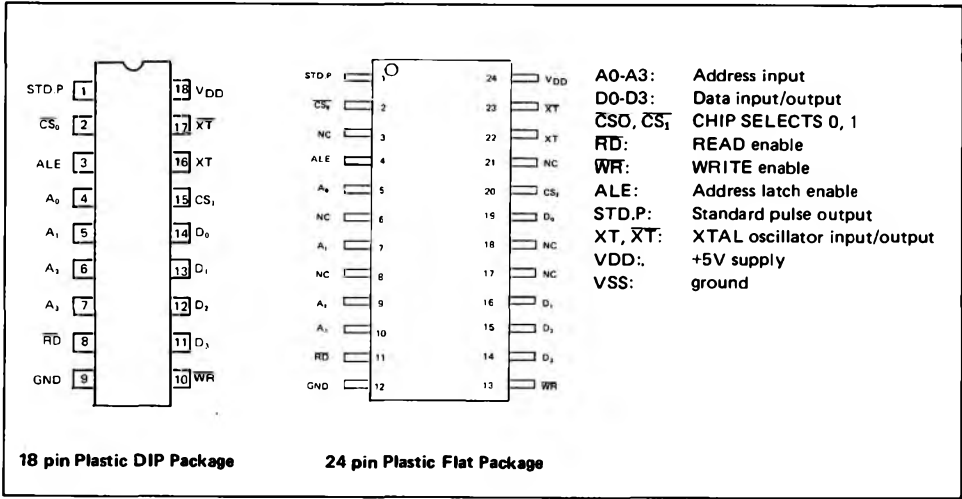

**REGISTER TABLE**

Address Input	Address Input				Register Name	Data				Count value	Description
	A <sub>3</sub>	A <sub>2</sub>	A <sub>1</sub>	A <sub>0</sub>		D <sub>3</sub>	D <sub>2</sub>	D <sub>1</sub>	D <sub>0</sub>		
0	0	0	0	0	S <sub>1</sub>	S <sub>8</sub>	S <sub>4</sub>	S <sub>2</sub>	S <sub>1</sub>	0 ~ 9	1-second digit register
1	0	0	0	1	S <sub>10</sub>	*	S <sub>40</sub>	S <sub>20</sub>	S <sub>10</sub>	0 ~ 5	10-second digit register
2	0	0	1	0	M <sub>1</sub>	m <sub>8</sub>	m <sub>4</sub>	m <sub>2</sub>	m <sub>1</sub>	0 ~ 9	1-minute digit register
3	0	0	1	1	M <sub>10</sub>	*	m <sub>40</sub>	m <sub>20</sub>	m <sub>10</sub>	0 ~ 5	10-minute digit register
4	0	1	0	0	H <sub>1</sub>	h <sub>8</sub>	h <sub>4</sub>	h <sub>2</sub>	h <sub>1</sub>	0 ~ 9	1-hour digit register
5	0	1	0	1	H <sub>10</sub>	*	PM/AM	h <sub>20</sub>	h <sub>10</sub>	0 ~ 2 or 0: 1	PM/AM, 10-hour digit register
6	0	1	1	0	D <sub>1</sub>	d <sub>8</sub>	d <sub>4</sub>	d <sub>2</sub>	d <sub>1</sub>	0 ~ 9	1-day digit register
7	0	1	1	1	D <sub>10</sub>	*	*	d <sub>20</sub>	d <sub>10</sub>	0 ~ 3	10-day digit register
8	1	0	0	0	MO <sub>1</sub>	mo <sub>8</sub>	mo <sub>4</sub>	mo <sub>2</sub>	mo <sub>1</sub>	0 ~ 9	1-month digit register
9	1	0	0	1	MO <sub>10</sub>	*	*	*	MO <sub>10</sub>	0 ~ 1	10-month digit register
A	1	0	1	0	Y <sub>1</sub>	y <sub>8</sub>	y <sub>4</sub>	y <sub>2</sub>	y <sub>1</sub>	0 ~ 9	1-year digit register
B	1	0	1	1	Y <sub>10</sub>	Y <sub>80</sub>	Y <sub>40</sub>	Y <sub>20</sub>	Y <sub>10</sub>	0 ~ 9	10-year digit register
C	1	1	0	0	W	*	w <sub>4</sub>	w <sub>2</sub>	w <sub>1</sub>	0 ~ 6	Week register
D	1	1	0	1	CD	30 sec. ADJ	IRQ FLAG	BUSY	HOLD	—	Control Register D
E	1	1	1	0	CE	t <sub>1</sub>	t <sub>0</sub>	ITRPT/STND	MASK	—	Control Register E
F	1	1	1	1	CF	TEST	24/12	STOP	REST	—	Control Register F

REST = RESET  
 ITRPT/STND = INTERRUPT/STANDARD

- Note 1) — Bit \* does not exist (unrecognized during a write and held at "0" during a read).
- Note 2) — Be sure to mask the AM/PM bit when processing 10's of hour's data.
- Note 3) — BUSY bit is read only. The IRQ FLAG bit can only be set to a "0". Setting the IRQ FLAG to a "1" is done by hardware.

Figure 1. Register Table

OSCILLATOR FREQUENCY DEVIATIONS

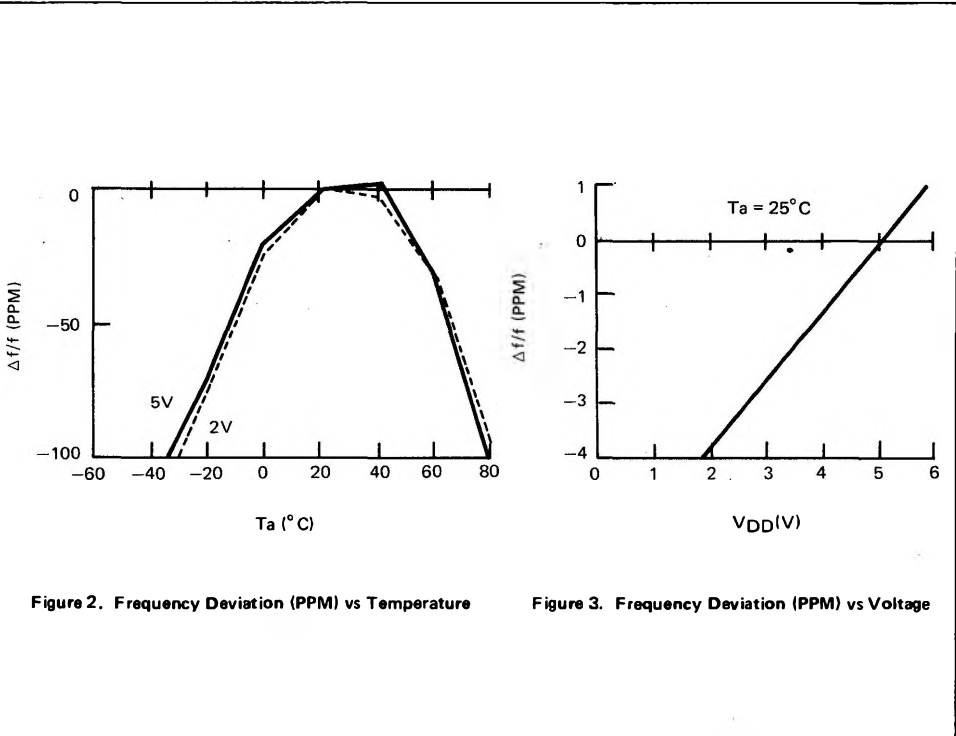

Note: 1. The graphs above showing frequency deviation vs temperature/voltage are primarily characteristic of the MSM6242 with the oscillation circuit described below.

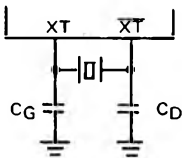

Crystal: Type N<sub>6</sub>, F<sub>3</sub> by kinseki (32.768 KHz)

CG, CD: 22pF (Temperature Characteristics: 0)

## ELECTRICAL CHARACTERISTICS

### ABSOLUTE MAXIMUM RATINGS

Parameter	Symbol	Condition	Rating	Unit
Power Supply Voltage	V <sub>DD</sub>	T <sub>a</sub> = 25°C	-0.3~ 7	V
Input Voltage	V <sub>I</sub>		GND - 0.3~V <sub>DD</sub> + 0.3	V
Output Voltage	V <sub>O</sub>		GND - 0.3~V <sub>DD</sub> + 0.3	V
Storage Temperature	T <sub>STG</sub>		-55~ +150	°C

### OPERATING CONDITIONS

Parameter	Symbol	Condition	Rating	Unit
Power Supply Voltage	V <sub>DD</sub>	-	4 ~ 6	V
Standby Supply Voltage	V <sub>BAK</sub>	-	2 ~ 6	
Crystal Frequency	f <sub>(XT)</sub>	-	32.768	kHz
Operating Temperature	T <sub>OP</sub>	-	-30~+85	°C

### D.C. CHARACTERISTICS

V<sub>DD</sub> = 5V ± 10%, T<sub>A</sub> = -30 ~ +85

Parameter	Symbol	Condition	Min.	Typ.	Max.	Unit	Applicable Terminal	
"H" Input Voltage	V <sub>IH1</sub>	-	2.2	-	-	V	All input terminals except CS <sub>1</sub>	
"L" Input Voltage	V <sub>IL1</sub>	-	-	-	0.8			
Input Leak Current	I <sub>LK1</sub>	V <sub>I</sub> = V <sub>DD</sub> /0V	-	-	1/-1	μA	Input terminals other than D <sub>0</sub> ~ D <sub>3</sub>	
Input Leak Current	I <sub>LK2</sub>		-	-	10/-10		D <sub>0</sub> ~ D <sub>3</sub>	
"L" Output Voltage	V <sub>OL1</sub>	I <sub>OL</sub> = 2.5mA	-	-	0.4	V	D <sub>0</sub> ~ D <sub>3</sub>	
"H" Output Voltage	V <sub>OH</sub>	I <sub>OH</sub> = -400μA	2.4	-	-			
"L" Output Voltage	V <sub>OL2</sub>	I <sub>OL</sub> = 2.5mA	-	-	0.4	V	STD.P	
OFF Leak Current	I <sub>OFFLK</sub>	V = V <sub>DD</sub> /0V	-	-	10	μA		
Input Capacitance	C <sub>I</sub>	Input frequency 1MHz	-	5	-	PF	All input terminals	
Current Consumption	I <sub>DD1</sub>	f <sub>(xt)</sub> = 32.768 KHz T <sub>a</sub> = 25°C	V <sub>DD</sub> = 5V	-	-	30	μA	V <sub>DD</sub>
Current Consumption	I <sub>DD2</sub>			V <sub>DD</sub> = 2V	-	-		
"H" Input Voltage	V <sub>IH2</sub>	V <sub>DD</sub> = 2~5.5V	4/5V <sub>DD</sub>	-	-	V	CS <sub>1</sub>	
"L" Input Voltage	V <sub>IL2</sub>		-	-	1/5V <sub>DD</sub>			

**SWITCHING CHARACTERISTICS**

**(1) WRITE mode (ALE = V<sub>DD</sub>)**

(V<sub>DD</sub> = 5V ± 10% = Ta = -30 ~ +85°C)

Parameter	Symbol	Condition	Min.	Max.	Unit
CS <sub>1</sub> Set up Time	t <sub>C1S</sub>	—	1000	—	ns
CS <sub>1</sub> Hold Time	t <sub>C1H</sub>	—	1000	—	
Address Stable Before WRITE	t <sub>AW</sub>	—	100	—	
Address Stable After WRITE	t <sub>WA</sub>	—	10	—	
WRITE Pulse Width	t <sub>WW</sub>	—	250	—	
Data Set up Time	t <sub>DS</sub>	—	180	—	
Data Hold Time	t <sub>DH</sub>	—	10	—	

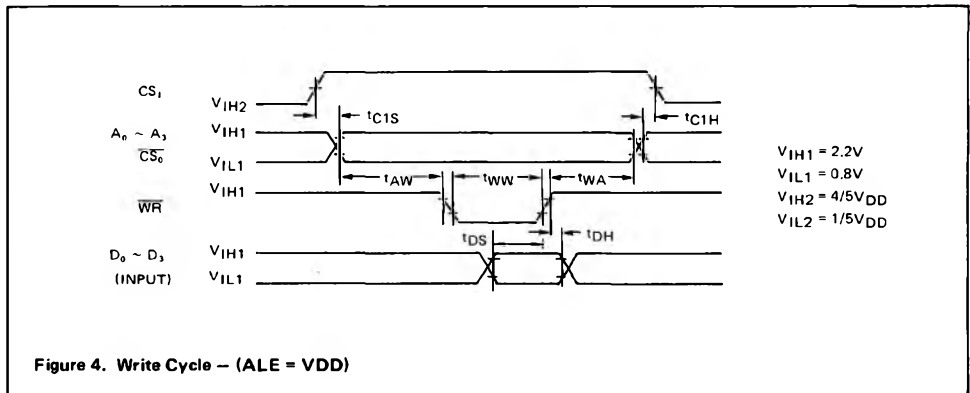

**(2) WRITE mode (With use of ALE)**

(V<sub>DD</sub> = 5V ± 10%, Ta = -3°C)

Parameter	Symbol	Condition	Min.	Max.	Unit
CS <sub>1</sub> Set up Time	t <sub>C1S</sub>	—	1000	—	ns
Address Set up Time	t <sub>AS</sub>	—	50	—	
Address Hold Time	t <sub>AH</sub>	—	50	—	
ALE Pulse Width	t <sub>AW</sub>	—	80	—	
ALE Before WRITE	t <sub>ALW</sub>	—	0	—	
WRITE Pulse Width	t <sub>WW</sub>	—	250	—	
ALE After WRITE	t <sub>WAL</sub>	—	50	—	
DATA Set up Time	t <sub>DS</sub>	—	180	—	
DATA Hold Time	t <sub>DH</sub>	—	10	—	
CS <sub>1</sub> Hold Time	t <sub>C1H</sub>	—	1000	—	

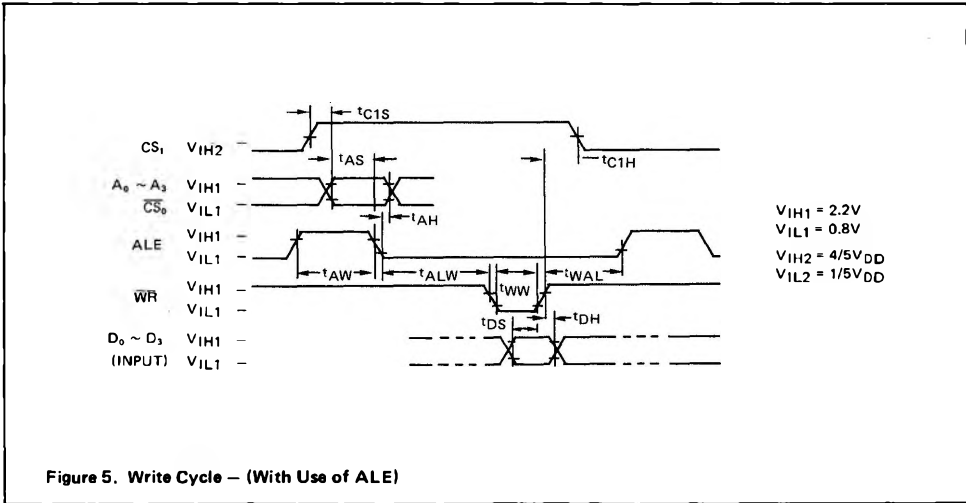

(3) READ mode (ALE = V<sub>DD</sub>)

(V<sub>DD</sub> = 5V ± 10%, T<sub>a</sub> = -30 ~ +85°C)

Parameter	Symbol	Condition	Min.	Max.	Unit
CS <sub>1</sub> Set up Time	t <sub>C1S</sub>	—	1000	—	ns
CS <sub>1</sub> Hold Time	t <sub>C1H</sub>	—	1000	—	
Address Stable Before READ	t <sub>AR</sub>	—	80	—	
Address Stable After READ	t <sub>RA</sub>	—	0	—	
$\overline{RD}$ to Data	t <sub>RD</sub>	C <sub>L</sub> = 150pF	—	280	
Data Hold	t <sub>DR</sub>	—	0	—	

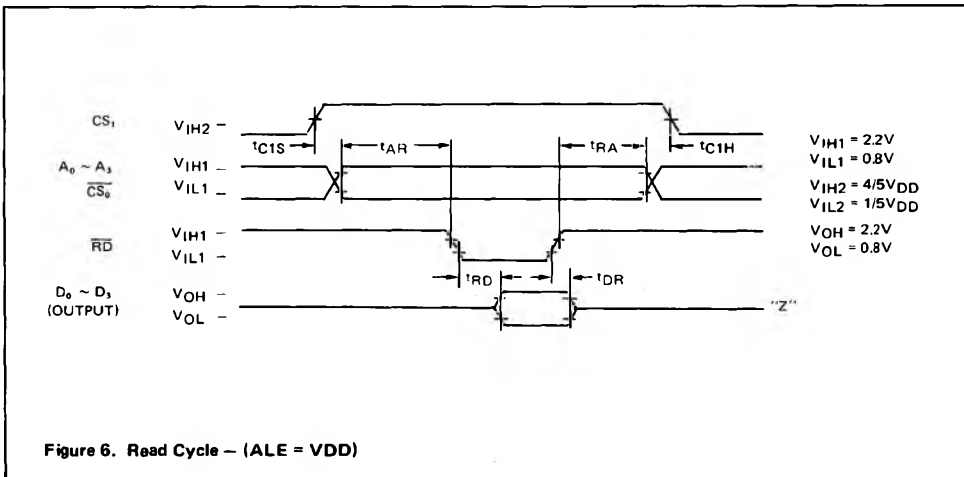

(4) READ mode (With use of ALE)

( $V_{DD} = 5V \pm 10\%$ ,  $T_a = -30 \sim +85^\circ C$ )

Parameter	Symbol	Condition	Min.	Max.	Unit
CS <sub>1</sub> Set up Time	t <sub>C1S</sub>	—	1000	—	ns
Address Set up Time	t <sub>AS</sub>	—	50	—	
Address Hold Time	t <sub>AH</sub>	—	50	—	
ALE Pulse Width	t <sub>AW</sub>	—	80	—	
ALE Before READ	t <sub>ALR</sub>	—	0	—	
ALE after READ	t <sub>RAL</sub>	—	0	—	
RD to Data	t <sub>RD</sub>	C <sub>L</sub> = 150pF	—	280	
DATA Hold	t <sub>DR</sub>	—	0	—	
CS <sub>1</sub> Hold Time	t <sub>C1H</sub>	—	1000	—	

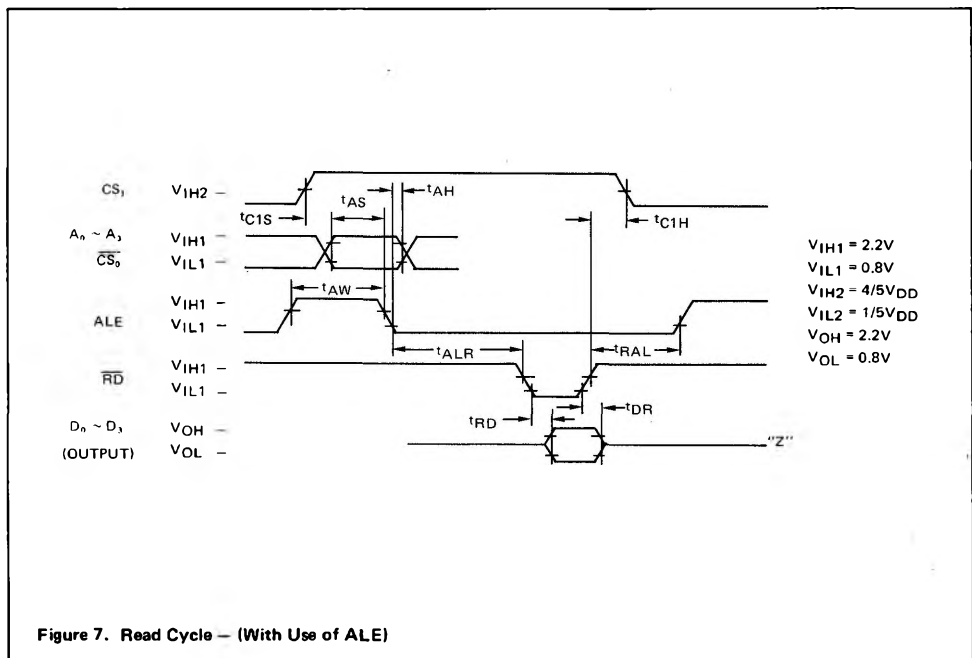

Figure 7. Read Cycle — (With Use of ALE)

**PIN DESCRIPTION**

Name	Pin No.		Description
	RS	GS	
D <sub>0</sub>	14	19	Data Input/Output pins to be directly connected to a microcontroller bus for reading and writing of the clock/calendar's registers and control registers. D <sub>0</sub> = LSB and D <sub>3</sub> = MSB.
D <sub>1</sub>	13	16	
D <sub>2</sub>	12	15	
D <sub>3</sub>	11	14	
A <sub>0</sub>	4	5	Address inputs pins for use by a microcomputer to select internal clock/calendar's registers and control registers for Read/Write operations (See Function Table Figure 1). Address input pins A <sub>0</sub> -A <sub>3</sub> are used in combination with ALE for addressing registers.
A <sub>1</sub>	5	7	
A <sub>2</sub>	6	9	
A <sub>3</sub>	7	10	
ALE	3	4	Address Latch Enable pin. This pin enables writing of address data when ALE = 1 and CS <sub>0</sub> = 0; address data is latched when ALE = 0. Microcontroller/Micro-processors having an ALE output should connect it to this pin; otherwise it should be connected at V <sub>DD</sub> .
WR	10	13	Writing of data is performed by this pin. When CS <sub>1</sub> = 1 and CS <sub>0</sub> = 0, D <sub>0</sub> ~ D <sub>3</sub> data is written into the register at the rising edge of WR.
RD	8	11	Reading of register data is accomplished using this pin. When CS <sub>1</sub> = 1, CS <sub>0</sub> = 0 and RD = 0, the data of the register is output to D <sub>0</sub> ~ D <sub>3</sub> . If both RD and WR are set at 0 simultaneously, RD is to be inhibited.
CS <sub>0</sub>	2	2	Chip Select Pins. These pins enable/disable ALE, RD and WR operation. CS <sub>0</sub> and ALE work in combination with one another, while CS <sub>1</sub> work independent with ALE. CS <sub>1</sub> must be connected to power failure detection as shown in Figure 18.
CS <sub>1</sub>	15	20	
STD.P	1	1	Output pin of N-CH OPEN DRAIN type. The output data is controlled by the D <sub>1</sub> data content of C <sub>E</sub> register. This pin has a priority to CS <sub>0</sub> and CS <sub>1</sub> . Refer to Figure 9 and FUNCTIONAL DESCRIPTION OF REGISTERS.
XT	16	22	32.768 kHz crystal is to be connected to these pins. When an external clock of 32.768 kHz is to be used for MSM6242's oscillation source, either CMOS output or pull-up TTL output is to be input from XT, while XT should be left open.
XT	17	23	
VDD	18	24	Power supply pin. +2 ~ +6V power is to be applied to this pin.
GND	9	12	Ground pin.
			<p>C<sub>1</sub> = C<sub>2</sub> = 15 ~ 30pF</p> <p>The impedance of the crystal should be less than 30kΩ</p> <p>Figure 8. Oscillator Circuit</p> <p>Figure 9.</p>



**FUNCTIONAL DESCRIPTION OF REGISTERS**

■  $S_1, S_{10}, MI_1, MI_{10}, H_1, H_{10}, D_1, D_{10}, M\bar{O}_1, M\bar{O}_{10}, Y_1, Y_{10}, W$

- a) These are abbreviations for SECOND1, SECOND10, MINUTE1, MINUTE10, HOUR1, HOUR10, DAY1, DAY10, MONTH1, MONTH10, YEAR1, YEAR10, and WEEK. These values are in BCD notation.
- b) All registers are logically positive. For example, (S8, S4, S2, S1) = 1001 which means 9 seconds.
- c) If data is written which is out of the clock register data limits, it can result in erroneous clock data being read back.
- d) PM/AM,  $h_{20}, h_{10}$   
 In the mode setting of 24-hour mode, PM/AM bit is ignored, while in the setting of 12-hour mode  $h_{20}$  is to be set. Otherwise it causes discrepancy. In reading out the PM/AM bit in the 24-hour mode, it is continuously read out as 0. In reading out  $h_{20}$  bit in the 12-hour mode, 0 is written into this bit first, then it is continuously read out as 0 unless 1 is being written into this bit.
- e) Registers Y1, Y10, and Leap Year. The MSM6242 is designed exclusively for the Christian Era and is capable of identifying a leap year automatically. The result of the setting of a non-existent day of the month is shown in the following example: If the date February 29 or November 31, 1985, was written, it would be changed automatically to March 1, or December 1, 1985 at the exact time at which a carry pulse occurs for the day's digit.
- f) The Register W data limits are 0–6 (Table 1 shows a possible data definition).

**TABLE 1**

$w_4$	$w_2$	$w_1$	Day of Week
0	0	0	Sunday
0	0	1	Monday
0	1	0	Tuesday
0	1	1	Wednesday
1	0	0	Thursday
1	0	1	Friday
1	1	0	Saturday

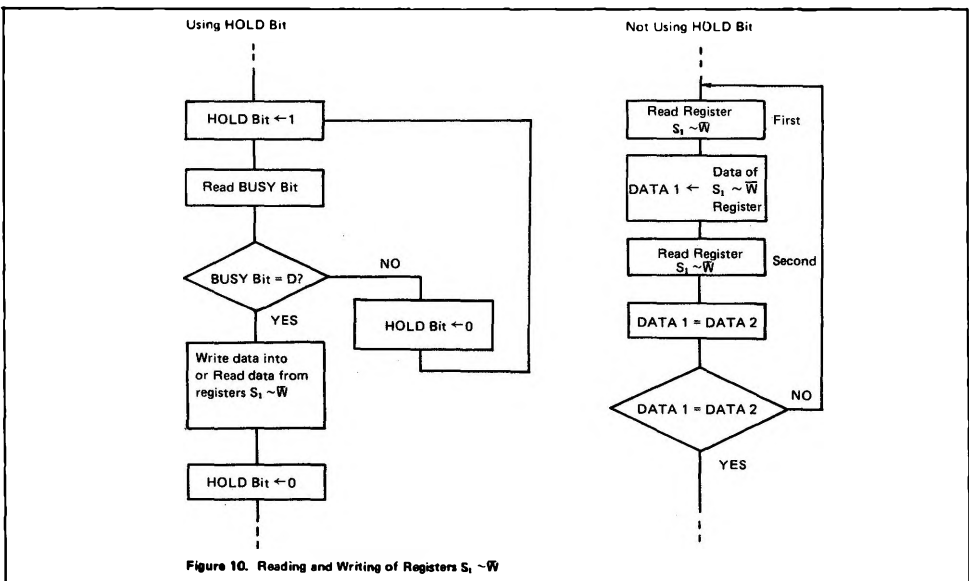

Figure 10. Reading and Writing of Registers  $S_1 \sim W$

■ CD REGISTER (Control D Register)

- a) HOLD (D0) – Setting this bit to a "1" inhibits the 1Hz clock to the S1 counter, at which time the Busy status bit can be read, and when Busy = 0 register's  $S_1 \sim W$  can be read or written. During this procedure if a carry occurs the S1 counter will be incremented by 1 second after HOLD = 0 (this condition is guaranteed as long as HOLD = 1 does not exceed 1 second in duration). If CS1 = 0 then HOLD = 0 irrespective of any condition.
- b) BUSY (D1) – Status bit which shows the interface condition with microcontroller/microprocessors. As for the method of writing into and reading from  $S_1 \sim W$  (address  $\phi \sim C$ ), refer to the flow chart described in Figure 10.
- c) IRQ FLAG (D2) – This status bit corresponds to the output level of the STD.P output. When STD.P = 0, then IRQ = 1; when STD.P = 1, then IRQ = 0. The IRQ FLAG indicates that an interrupt has occurred to the microcomputer if IRQ = 1. When D0 of register  $C_E$  (MASK) = 0, then the STD.P output changes according to the timing set by D3 ( $t_1$ ) and D2 ( $t_0$ ) of register E. When D1 of register E (ITRPT/STND) = 1 (interrupt mode), the STD.P output remains low until the IRQ FLAG is written to a "0". When IRQ = 1 and timing for a new interrupt occurs, the new interrupt is ignored. When ITRPT/STND = 0 (Standard Pulse Output mode) the STD.P output remains low until either "0" is written to the IRQ FLAG; otherwise, the IRQ FLAG automatically goes to "0" after 7.8125 ms.  
 When writing the HOLD or 30 second adjust bits of register D, it is necessary to write the IRQ FLAG bit to a "1".
- d)  $\pm 30$  ADJ (D3) – When 30-second adjustment is necessary, a "1" is written to bit D3 during which time the internal clock registers should not be read from or written to 125 $\mu$ s after bit D3 = 1 it will automatically return to a "0", and at that time reading or writing of registers can occur.

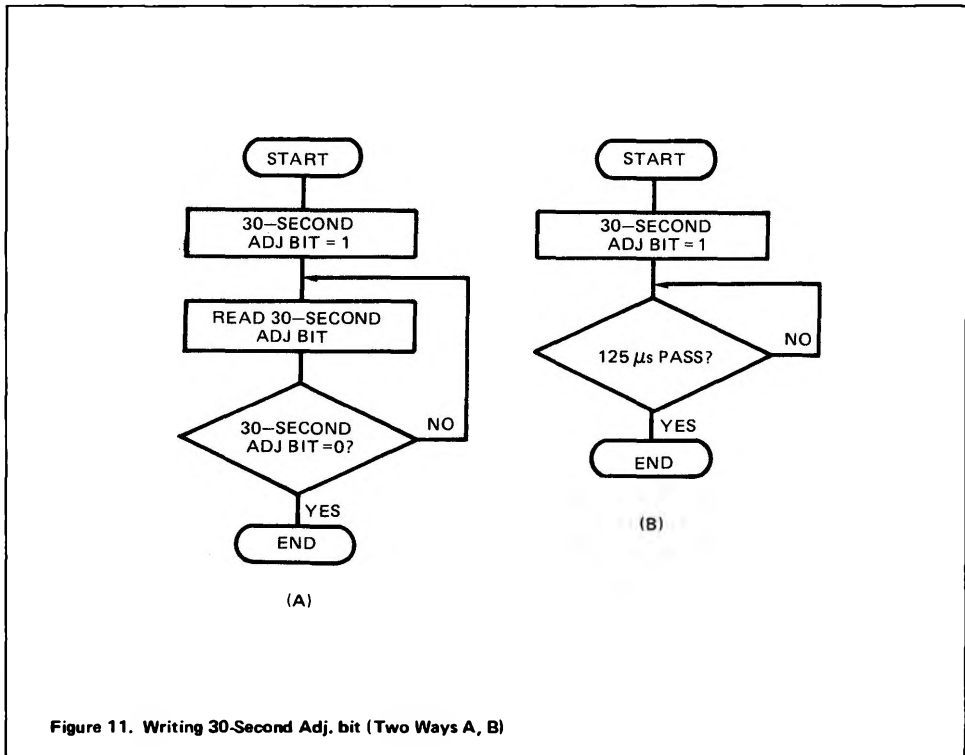

Figure 11. Writing 30-Second Adj. bit (Two Ways A, B)

■ CE REGISTER (Control E Register)

- a) MASK (D0) — This bit controls the STD.P output. When MASK = 1, then STD.P = 1 (open); when MASK = 0, then STD.P = output mode. The relationship between the MASK bit and STD.P output is shown Figure 12.
- b) INTRPT/STND (D1) — The INTRPT/STND input is used to switch the STD.P output between its two modes of operation. Interrupt and Standard timing waveforms. When INTRPT/STND = 0 a fixed cycle waveform with a low-level pulse width of 7.8125 ms is present at the STD.P output. At this time the MASK bit must = 0, while the period in either mode is determined by T0(D2) and T1(D3) of Register E.
- c) T0 (D2), T1 (D3) — These two bits determine the period of the STD.P output in both Interrupt and Fixed timing waveform modes. The tables below show the timing associated with the T0, T1 inputs as well as their relationship to INTRPT/STND and STD.P.

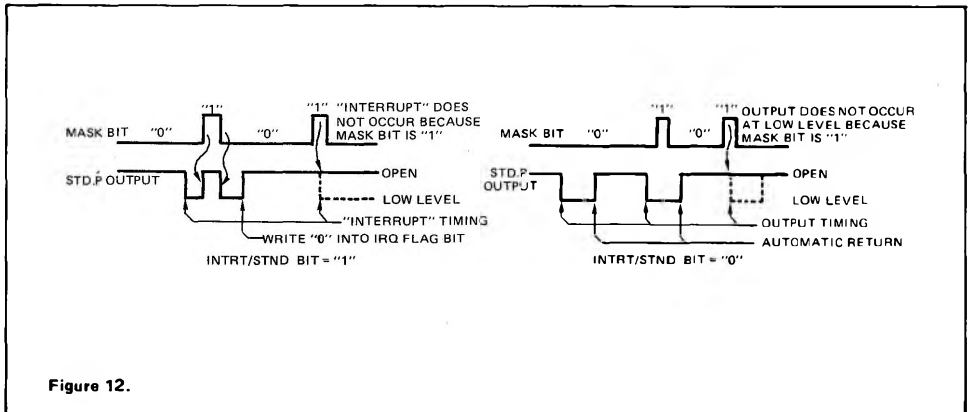
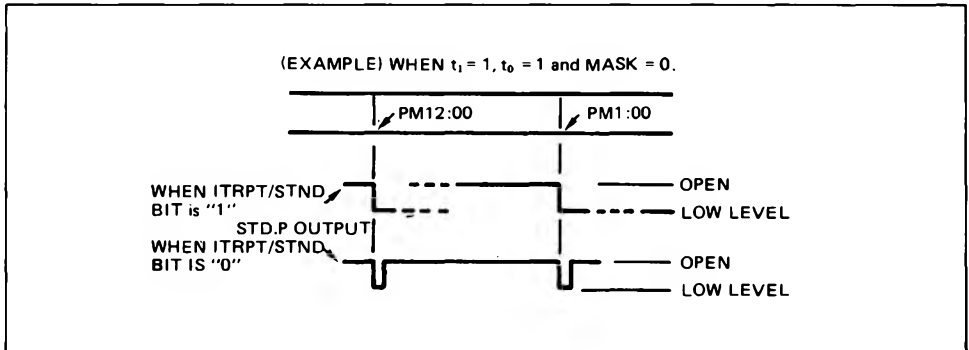

Figure 12.

t <sub>1</sub>	t <sub>0</sub>	Period	Duty CYCLE of "0" level when ITRPT/STND bit is "0".
0	0	1/64 second	1/2
0	1	1 second	1/128
1	0	1 minute	1/7680
1	1	1 hour	1/560800

TABLE 2

The timing of the STD.P output designated by T1 and T0 occurs the moment that a carry occurs to a clock digit.



- d) The low-level pulse width of the fixed cycle waveform (ITRPT/STND = 0) is 7.8125 ms independent of T0/T1 inputs.
- e) The fixed cycle waveform mode can be used for adjustment of the oscillator frequency time base. (See Figure 14).
- f) During  $\pm 30$  second adjustment a carry can occur that will cause the STD.P output to go low when T0/T1 = 1,0 or 1,1. However, when T1/T0 = 0, 0 and ITRPT/STND = 0, carry does not occur and the STD.P output resumes normal operation.
- g) The STD.P output is held (frozen) at the point at which STOP = 1 while ITRPT/STND = 0.
- h) No STD.P output change occurs as a result of writing data to registers S1 ~ H1.

■ **C<sub>F</sub> REGISTER (Control F Register)**

- a) REST (D0) – This bit is used to clear the clock's internal divider/counter of less than a second. When "RESET" REST = 1, the counter is Reset for the duration of REST. In order to release this counter from Reset, a "0" must be written to the REST bit. If CSO = 0 then REST = 0 automatically.
- b) STOP (D1) – The STOP FLAG Only inhibits carries into the 8192Hz divider stage. There may be up to 122 $\mu$ s delay before timing starts or stops after changing this flag; 1 = STOP/0 = RUN.

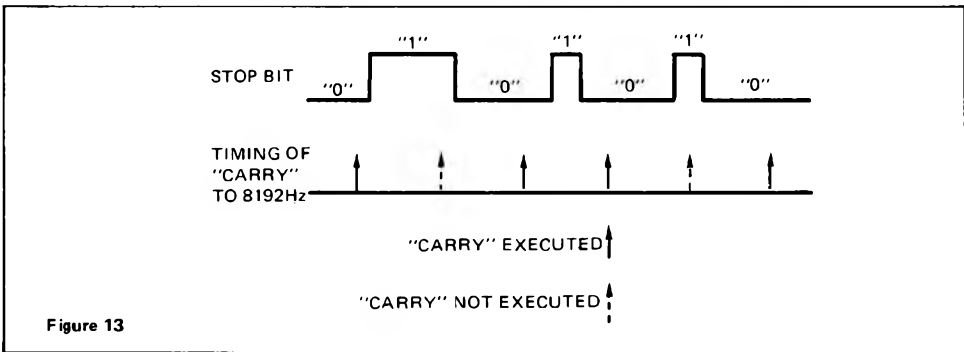

- c) 24/12 (D2) – This bit is for selection of 24/12 hour time modes. If D2 = 1—24 hour mode is selected and the PM/AM bit is invalid. If D2 = 0—12 hour mode is selected and the PM/AM bit is valid.  
 "24 HOUR/  
12 HOUR"  
 Setting of the 24/12 hour bit is as follows:  
 1) REST bit = 1  
 2) 24/12 hour bit = 0 or 1  
 3) REST bit = 0  
 \* REST bit must = 1 to write to the 24/12 hour bit.
- d) TEST (d3) – When the TEST flag is a "1", the input to the SECONDS counter comes from the counter/divider stage instead of the 15th divider stage. This makes the SECONDS counter count at 5.4163KHz instead of 1Hz. When TEST = 1 (Test Mode) the STOP & REST (Reset) flags do not inhibit internal counting. When Hold = 1 during Test (Test = 1) internal counting is inhibited; however, when the HOLD FLAG goes inactive (Hold = 0) counter updating is not guaranteed.

TYPICAL APPLICATION INTERFACE WITH MSM6242 AND MICROCONTROLLERS

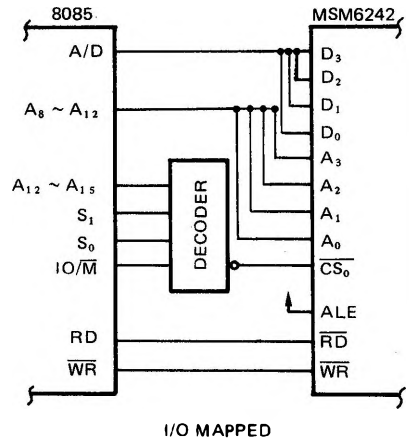
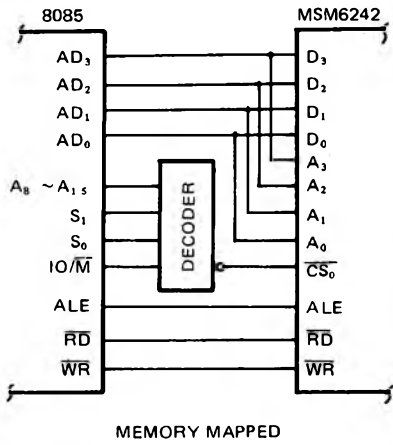

Figure 15.

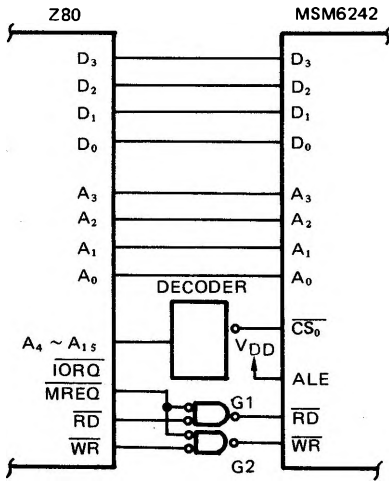

Figure 16.

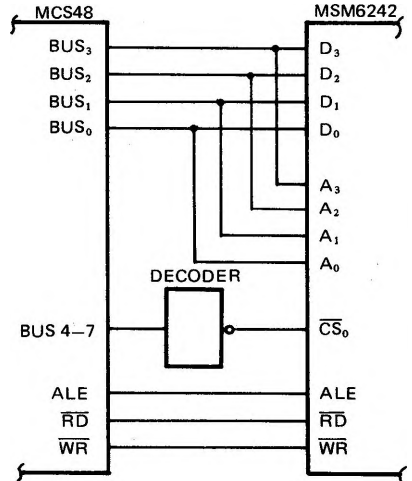

Figure 17.

TYPICAL APPLICATIONS – INTERFACE WITH MSM80C49

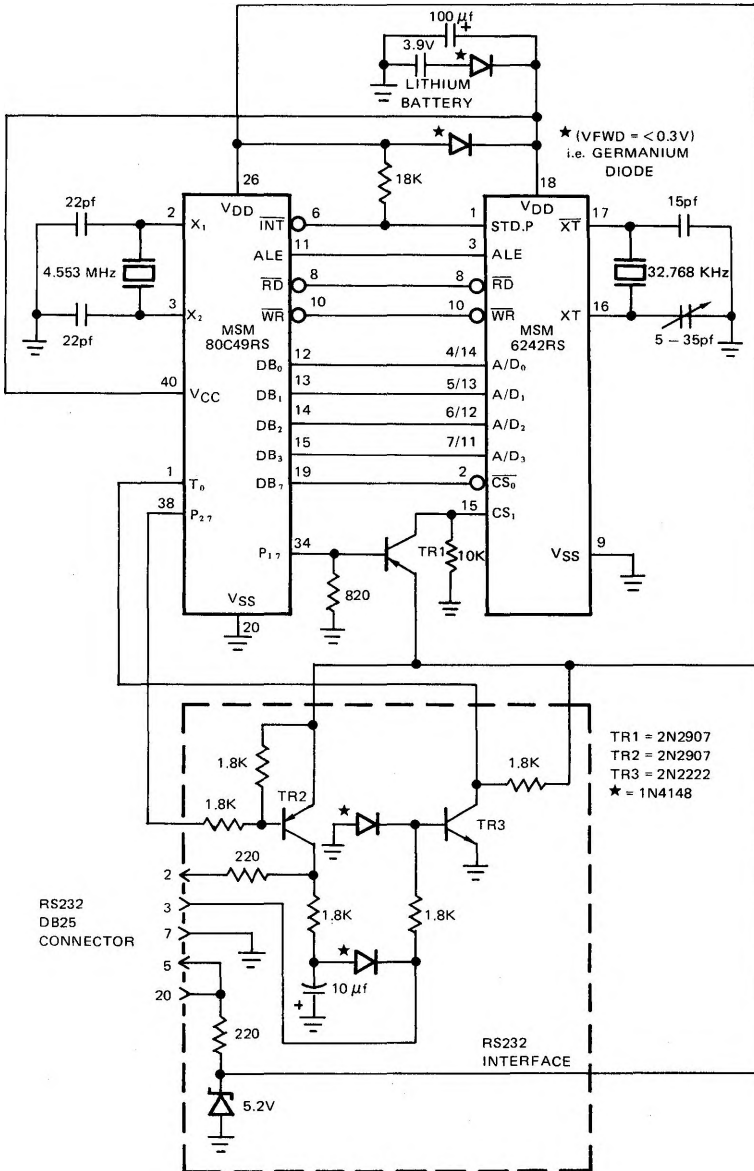
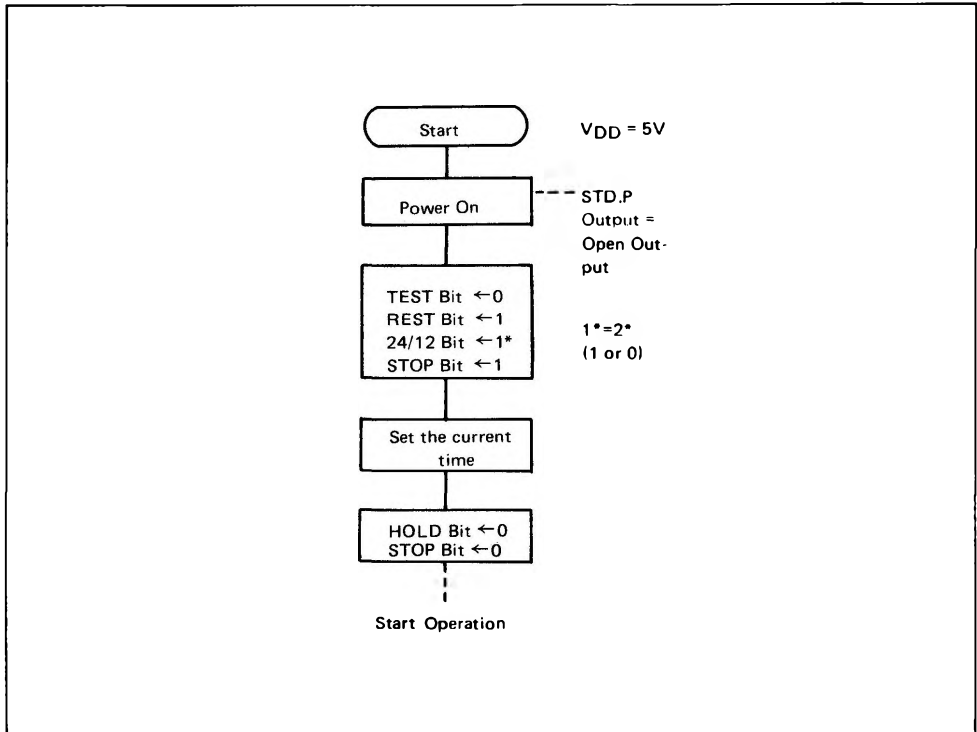

Figure 18.

## APPLICATION NOTE

### 1. Power Supply



### 2. Adjustment of Frequency

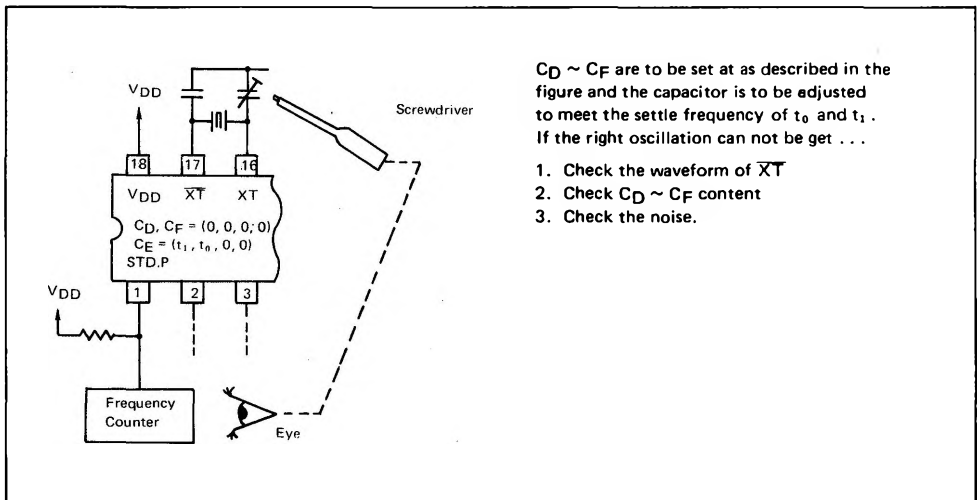

### 3. CH<sub>1</sub> (Chip Select)

V<sub>IH</sub> and V<sub>IL</sub> of CH<sub>1</sub> has 3 functions.

- To accomplish the interface with microcontroller/microprocessor.
- To inhibit the control bus, data bus and address bus in the stand-by mode.
- To protect MSM6242 device when the mode is moved to and from standby mode.

To realize above functions:

- More than 4/5 V<sub>DD</sub> should be applied to MSM6242 for the interface with microcontroller/microprocessor in 5V operation.
- In moving to the standby mode, 1/5 V<sub>DD</sub> should be applied so that all data bus should be disabled. In the standby mode, approx. 0V should be applied.
- To and from the standby mode, please obey following Timing chart.

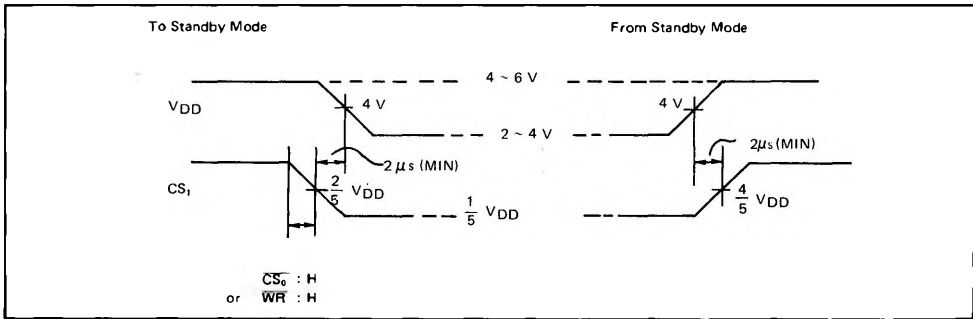

### 4. Set STD.P at alarm mode

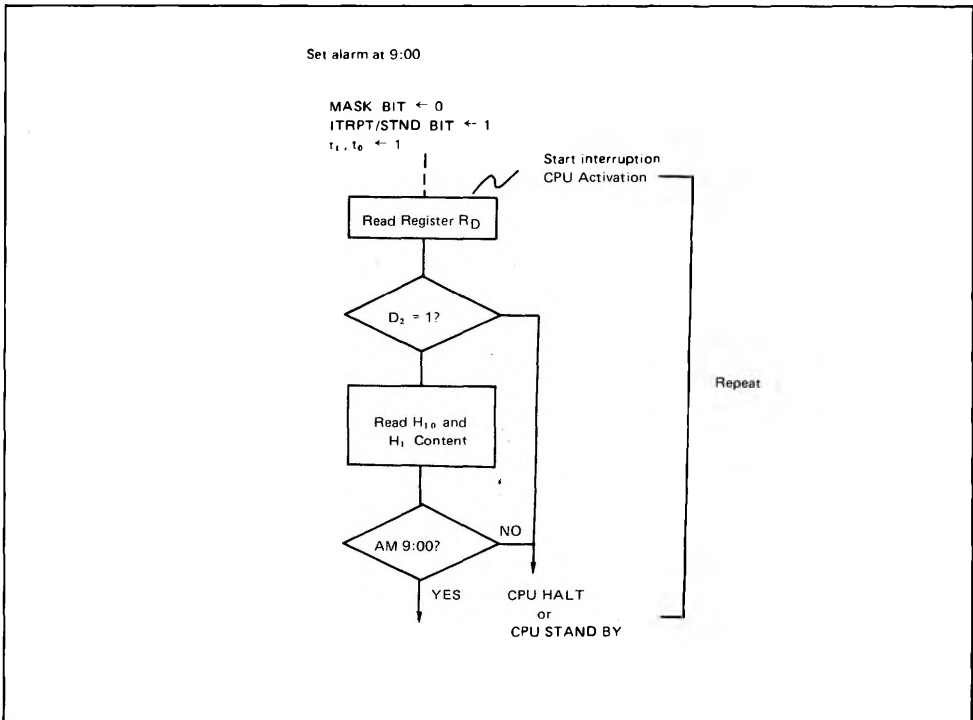



TYPICAL APPLICATION — POWER SUPPLY CIRCUIT

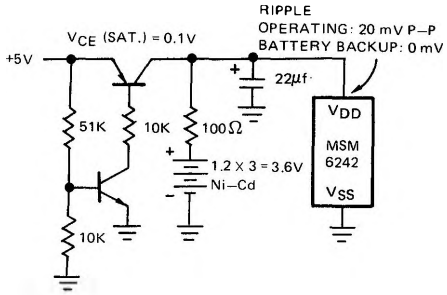

Figure 19.

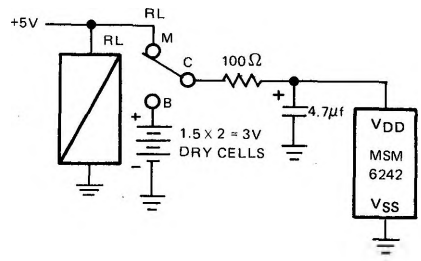

Figure 20.

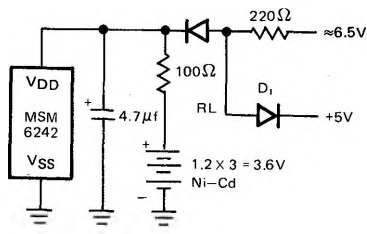

Figure 21.