



LED SPECIFICATION

Part No.: **3751MR2D**

Features:

- Single color
- High bright output
- Low power consumption
- High reliability and long life

Descriptions:

- Dice material: AlGaInP
- Emitting Color: Super Bright Red
- Device Outline: 5.2×3.8mm Oval Type
- Lens Type: Red Diffused

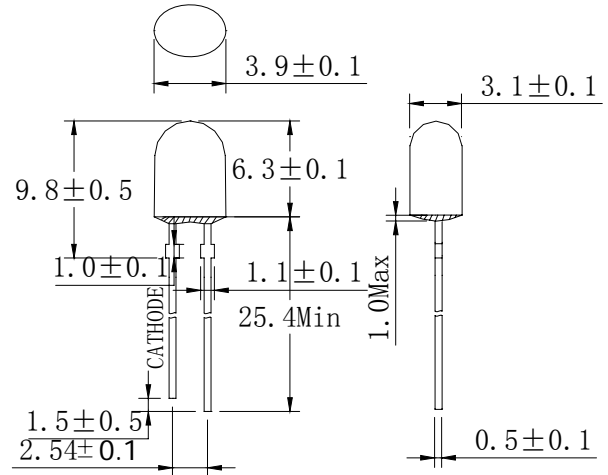

NOTE:

- All dimensions are millimetres.
- Tolerance is +/-0.25mm unless otherwise noted.

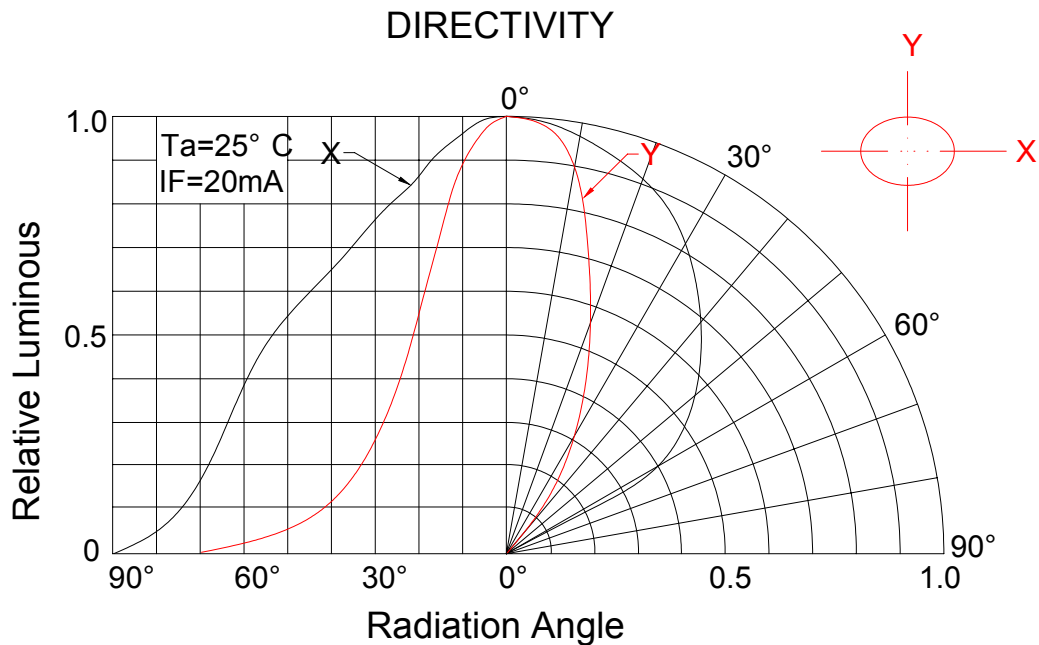



LED SPECIFICATION

Part No.: 7511MR2D

Absolute maximum ratings (Ta = 25°C)

| Parameter | Symbol | Test Condition | Value | | Unit |
|-----------------------|-------------------|------------------------|-------|------|------|
| | | | Min. | Max. | |
| Reverse Voltage | V _R | I _R = 30 μA | 5 | -- | V |
| Forward Current | I _F | ---- | ---- | 30 | mA |
| Power Dissipation | P _d | ---- | ---- | 70 | mW |
| Pulse Current | I _{peak} | Duty=0.1mS, 1kHz | ---- | 100 | mA |
| Operating Temperature | T _{opr} | ---- | -20 | +85 | °C |
| Storage Temperature | T _{str} | ---- | -25 | +100 | °C |

Electrical and optical characteristics (Ta = 25°C)

| Parameter | Symbol | Test Condition | Value | | | Unit |
|--------------------------|----------------|-----------------------|-------|--------|------|------|
| | | | Min. | Typ. | Max. | |
| Forward Voltage | V _F | I _F = 20mA | ---- | 2.0 | 2.5 | V |
| Reverse Current | I _R | V _R = 5V | ---- | ---- | 30 | μA |
| Dominate Wavelength | λ _d | I _F = 20mA | ---- | 625 | ---- | nm |
| Spectral Line half-width | Δλ | I _F = 20mA | ---- | 20 | ---- | nm |
| Luminous Intensity | I _v | I _F = 20mA | ---- | 400 | --- | mcd |
| Viewing Angle | 2θ 1/2 | I _F = 20mA | ---- | 110/50 | --- | Deg. |



LED SPECIFICATION

Part No.: 7511MR2D

Typical electrical/optical characteristic curves:

