

Device Selection Guide

Part Number EOL-	Luminous Intensity I_v (mcd) @ $I_F = 20$ mA		Viewing Angle $2\theta_{1/2}$ @ $I_F = 20$ mA	Dominant Wavelength λ_d (nm) @ $I_F = 20$ mA	V_F @ $I_F = 20$ mA		I_R (μ A) @ $V_R = 5$ V	Stand Off	Epoxy Color
	Min.	Typ.	Typ.	Typ.	Typ.	Max.	Max.		
5GBCCC0-EG	2225	2900	13°	470	3.4	4.0	100	No	Clear

BIN#	U	V			
Intensity(mcd) ^[1] @ $I_F = 20$ mA	2225-3115	3115-4360			

Notes: [1] Tolerance Value of $I_v \pm 15\%$.

Package Dimensions

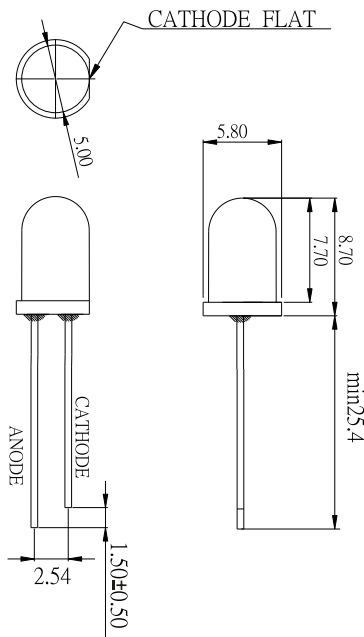

Beam Pattern

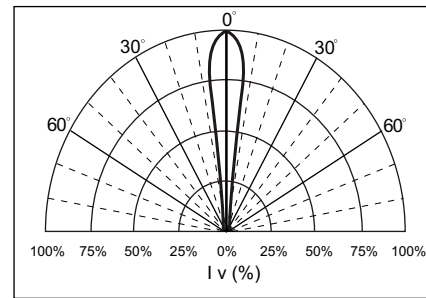

Note:

- All dimensions are in millimeter (mm).
- Unspecified tolerance: ± 0.20 mm.
- Protruded resin 1.5mm max.
- Lead spacing is measured where the leads emerge from the package
- Specifications are subject to change without notice.

Absolute Maximum Ratings at $T_A = 25^\circ\text{C}$

Parameter	Symbol		<i>USER---APPROVED</i>
Peak Forward Current	I_{fm}	50mA	
Average Forward Current	I_f	20mA	
Reverse Voltage	V_r	5V	
Operating Temperature Range	T_{opr}	-40°C to + 85°C	
Storage Temperature Range	T_{sto}	-40°C to + 100°C	
Lead Soldering Temperature	T_{sol}	260°C / 5 Secondes	

Notes: Duty Ratio=1/10, Pulse Width=10 ms