

Device Selection Guide

Part Number EOL-	Luminous Intensity I _v (mcd) @ I _F = 20mA		Viewing Angle 2θ _{1/2}	Dominant Wavelength λ _D (nm) @ I _F = 20mA	Forward Voltage V _F (V) @ I _F = 20 mA		I _R (μA) @ V _R = 5V	Stand Off	Epoxy Color
	Min.	Typ.	Typ.	Typ.	Typ.	Max.	Max.		
55BFCC0-EG	1135	2000	30°	470	3.4	4.0	50	No	Clear

BIN #	S	T	U*		
Intensity (mcd) @ I _F =20mA	1135-1590	1590-2225	2225-3115		

Note : [*] Bin with less distribution.

Package Dimensions

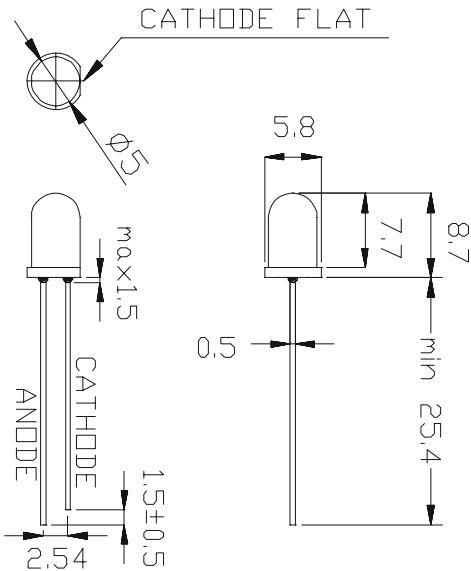

Beam Pattern

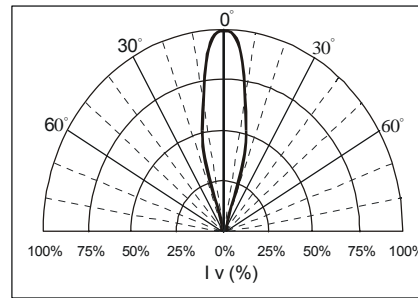

Note:

- All dimensions are in millimeter.
- Unspecified tolerance : ±0.20mm.
- Protruded resin under bottom surface of epoxy is 1.5mm max.
- Lead spacing is measured where the leads emerge from the package
- Specifications are subject to be changed without notice.

Absolute Maximum Ratings at T_A = 25°C

Parameter	Symbol	Maximum Value	USER---APPROVED
Average Forward Current	I _F	20mA	
Peak Forward Current ^[a]	I _{peak}	50mA	
Reverse Voltage	V _R	5V	
Power Dissipation	P _D	80mW	
Operating Temperature Range	T _{OPR}	-40°C ~ + 85°C	
Storage Temperature Range	T _{STO}	-40°C ~ + 100°C	
Lead Soldering Temperature	T _{SOL}	260°C / 5 seconds	

Notes: [a] Duty Ratio = 1/10, Pulse Width = 0.1ms.

Headquarters

5F, No. 1, Creation Road II, Hsinchu Science Park,
Hsinchu, Taiwan 300, R.O.C.

Tel : 886-3-5679000 Fax : 886-3-5679999

http://www.eoi.com.tw E-mail : Service@eoi.com.tw

U.S. Office

1400 W. Lambert Road, Suite B,
Brea, CA92821, U.S.A

Tel : 1-562-694-1246 Fax : 1-562-691-3087

http://www.eoi-us.com E-mail : Sales@eoius.com

