

# switches

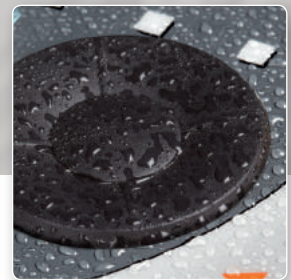
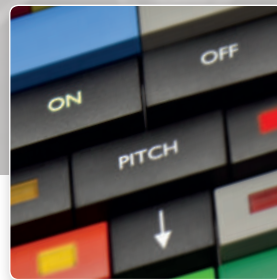

**SINCE 1938**  
**DANISH DESIGN**  
**IN-HOUSE R&D AND PRODUCTION**  
**IN-LINE QUALITY CONTROL**

Since its foundation in 1938, MEC has been making state-of-the-art electromechanical components.

Located in a suburb of Copenhagen, Denmark, MEC has earned a reputation as one of the leading European manufacturers of high performance tactile switches.

A wealth of know-how has been built up over the years for the benefit of innovative product development and custom solutions.

Despite the trend of outsourcing it has been MEC policy to maintain a high degree of vertical integration that enables us to react promptly to customer requests. 98% of all the parts used in MEC switches are produced in-house.

With 100% in-line inspection, tight tolerance on all parts and use of only quality materials we position ourselves to reach the highest achievable level within high performance tactile switches.

The vertical integration combined with a strong R&D facility enables us to provide custom designs from conception to completion.

To be part of a sustainable industrialised world environmental consciousness is crucial. At MEC we have substituted materials to more environmental-friendly alternatives and are recycling as much as possible. Legal authorities are auditing our environmental management system regularly and confirming that our goal is being reached. All MEC products are RoHS compatible.

MEC have a well established global distribution network that provides a presence in all parts of the world where electronic manufacturing takes place. Through close contact and continuous product training offered to our distributors we maintain a highly qualified and responsive global distribution network.

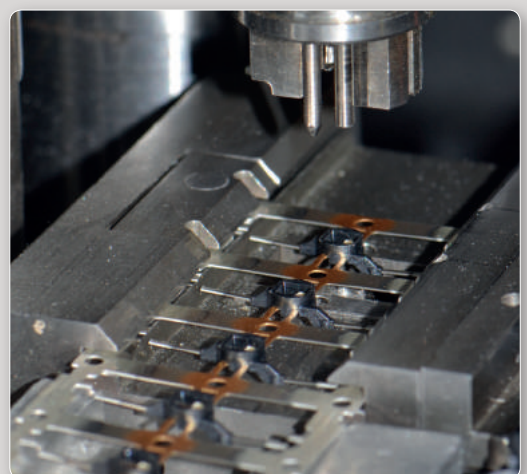
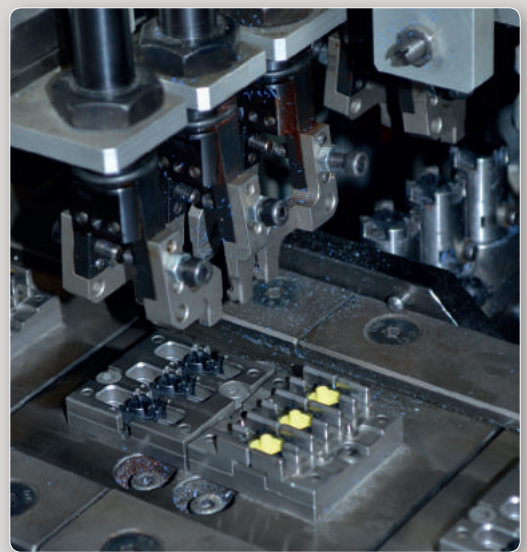

# Table of content

Selection guide for caps and accessories. . . . .	4
---	---

## multimec® caps

■ Introduction to Caps . . . . .	5
■ Introduction to Illumination . . . . .	6
■ Introduction to Panel Sealed and Foil solutions . . . . .	7
■ 1A/1H/1M/1ZA . . . . .	8
■ 1B/1C+2C/2D . . . . .	9
■ 1DS/1ES/1FS . . . . .	10
■ 1GAS/1GCS . . . . .	11
■ 1JS . . . . .	12
■ 1KS/1KBS/1KCS . . . . .	13
■ 1NS . . . . .	14
■ 1PS/1QS/1RS . . . . .	15
■ 1SS/1IS/1LS . . . . .	16
■ 1TS/1US/1VS + +1TW/1UW/1VW . . . . .	17
■ 1WAS/1WDS/1WPS . . . . .	18
■ 1XS . . . . .	19
■ foilmec™ 1YS . . . . .	20
■ navimec™ 1ZCS/1ZB . . . . .	21
■ navimec™ module . . . . .	22
■ controlmec™ 1ZW . . . . .	23
■ controlmec™ 1Z . . . . .	24
■ controlmec™ module . . . . .	25
■ 10R/10RF/10RM . . . . .	26
■ 10Q/10QM . . . . .	27
■ varimec™ . . . . .	30
■ aquamec™ . . . . .	32
■ Extender 2SS . . . . .	33
■ Legends . . . . .	34

Selection guide for switches. . . . .	36
---------------------------------------	----

## multimec® switches

■ Introduction to Switches . . . . .	37
■ 5 series switches . . . . .	38
■ 3C/3E series switches . . . . .	40
Technical information . . . . .	41
Technical Information - spacing . . . . .	42
Technical Information - module . . . . .	43
Technical Specifications - 5 series. . . . .	44
Technical Specifications - 3 series. . . . .	45
Technical Specifications - LEDs . . . . .	46

## unimec™ caps and switches

■ Introduction to unimec™ . . . . .	47
■ 16324-16326 . . . . .	48
■ 16310-16315 . . . . .	49
■ 16300/16700/16800. . . . .	50
■ Legends . . . . .	51
■ unimec™ switches. . . . .	52
vario™ support . . . . .	53
unimec™ with multimec® caps . . . . .	54
Technical Specifications. . . . .	55

## Custom

■ Custom products . . . . .	56
■ Custom products . . . . .	57

## General

Applications . . . . .	28
Solid Colours . . . . .	58
Usage Guidelines . . . . .	59

# Caps and accessories series

## Selection guide

	NON-ILLUMINATED	NON-ILLUMINATED & ILLUMINATED				ILLUMINATED
ROUND	<b>1SS</b> Ø6.5mm h=8.0 - 22.5mm *for 5E 	<b>1JS</b> Ø9.6mm h=10.4mm 	<b>1DS</b> Ø9.6mm h=14.9mm 	<b>1GAS</b> Ø11mm h=12.5mm 	<b>1IS</b> Ø6.5mm h=10.4 - 22.5mm 	
	<b>varimec™ round</b> Ø5.2; 7.8; 11.6mm h=10.4-22.5mm *for 3E 	<b>1US</b> Ø10.6mm h=14.9mm 	<b>1ZCS</b> Ø14.3mm h=11.7mm 	<b>1GCS</b> Ø15mm h=12.5mm 	<b>1LS</b> Ø6.5mm h=12.0mm-22.5mm 	
		<b>1Z</b> Ø29.5mm h=12.0mm 	<b>1ZW</b> Ø29.5mm h=12.3mm 	<b>aquamec</b> Ø10.6mm h from front panel=14.3mm h=24.2-27.2mm 	<b>1ES</b> Ø9.6mm h=14.9mm 	
		<b>10R/10RF</b> Ø30mm h=12.6/11.0mm 	<b>10RM16</b> Ø30mm h=11.0mm 	<b>navimec</b> Ø34.25mm h=11.7/12.2mm 	<b>1FS</b> Ø9.6mm h=14.9mm 	
SQUARE/RECTANGULAR	<b>1ZA</b> 18.65x10.1mm h=12.2mm 	<b>1PS</b> 12.5x6.5mm h=15.7mm 	<b>1XS</b> 7.4x9.4mm h=18.5mm 	<b>1QS</b> 12.5x6.5mm h=15.7mm 	<b>1RS</b> 12.5x6.5mm h=15.7mm 	
	<b>1M</b> 25.0x10.1mm h=12.2mm 	<b>1A</b> 12.5x10.1mm h=12.2mm 	<b>1TS</b> 10.6x10.6mm h=14.9mm 	<b>1H</b> 12.5x10.1mm h=12.2mm 	<b>1C + 2C/2D</b> 15.1x15.1mm h=12.2mm 	
	<b>varimec™ square</b> 5.2x5.2; 7.8x7.8; 11.6x11.6mm h=10.4-22.5mm *for 3E 	<b>1B + 2C/2D</b> 15.1x15.1mm h=12.2mm 	<b>1KS</b> 14.3x14.3mm h=19.1mm 	<b>2K</b> 17.75x17.75mm 	<b>1KBS</b> 14.3x14.3mm h=20.2mm 	
	<b>unimec™ 16300</b> 6.0x12.3mm h=16.9mm 	<b>10Q</b> 22x22mm h=11.0mm 	<b>10QM16</b> 22x22mm h=11.0mm 		<b>1KCS</b> 14.3x14.3mm h=20.1mm 	
	<b>unimec™ 16700</b> 14.9x14.9mm h=14.6mm 				<b>1YS</b> 15x15mm h=12.5mm *for 5E 	
OTHER	<b>2SS</b> extender for 5G snap on caps h=5-10mm 	<b>1NS</b> Ø9.6/□4.9mm h=14.9mm 	<b>1VS</b> 10.6x13.25mm h=14.9mm 	<b>1ZB</b> 90° R=17.5mm h=12.2mm 		
	<b>1TW/1UW/1VW</b> sealing for 1TS/1US/1VS 	<b>1WAS</b> 6.5x12.5mm h=14.9mm 	<b>1WDS</b> 8.0x15.2mm h=14.9mm 	<b>1WPS</b> 6.5x12.5mm h=15.7mm 		

\*Caps are for 5G if not otherwise specified

## CAPS

MANY OPTIONS REGARDING:

SHAPE, SIZE, HEIGHT, COLOUR AND ILLUMINATION

SOLUTIONS:

NAVIMEC™, CONTROLMEC™, FOILMEC™, VARIMEC™, AQUAMEC™



MEC has a wide range of caps for the multimec® switch series. There are many cap series including navimec™, controlmec™ foilmec™ and aquamec™ for multimec® 5 series switches, and varimec™ that is still for the 3 series switches.

18 solid colours and 6 transparent colours

Overall height varies from 8.0 mm to 27.2 mm



## ILLUMINATION

SINGLE- OR BI-COLOUR

MANY OPTIONS IN LED, CAP AND LENS COLOUR

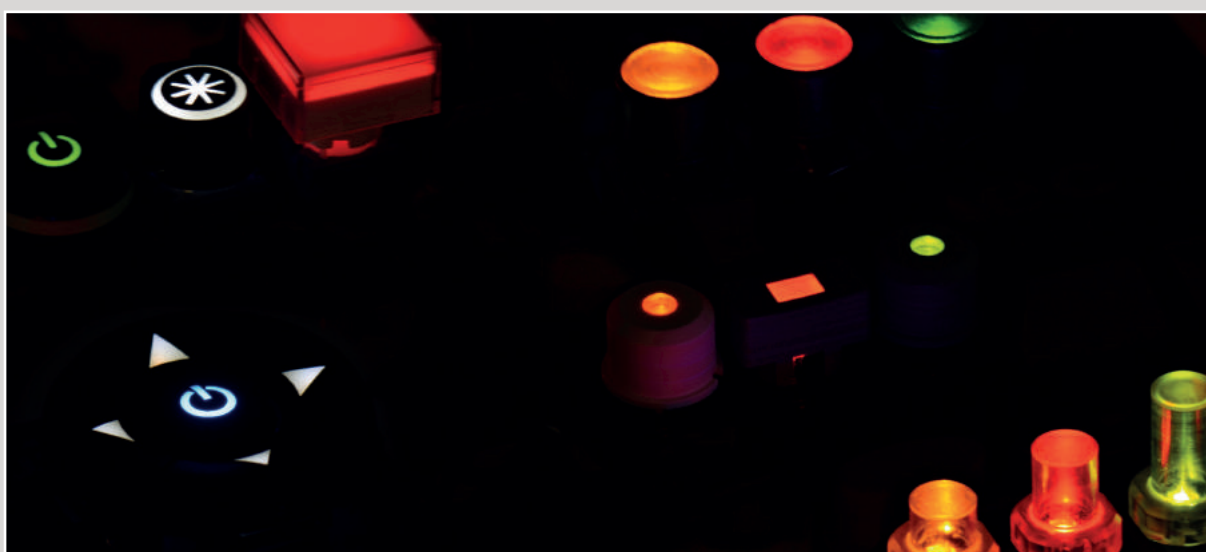

5 LED colour options available: blue, green, yellow, white and red.

Bi-colour combination can be made with any two LED colours.

Illumination can be full, dot, rectangular or legend.



MEC cap range includes options for the front panel sealing. We have designed cap options for outdoor, dusty and humid applications - switch solutions that can endure a rough environment.

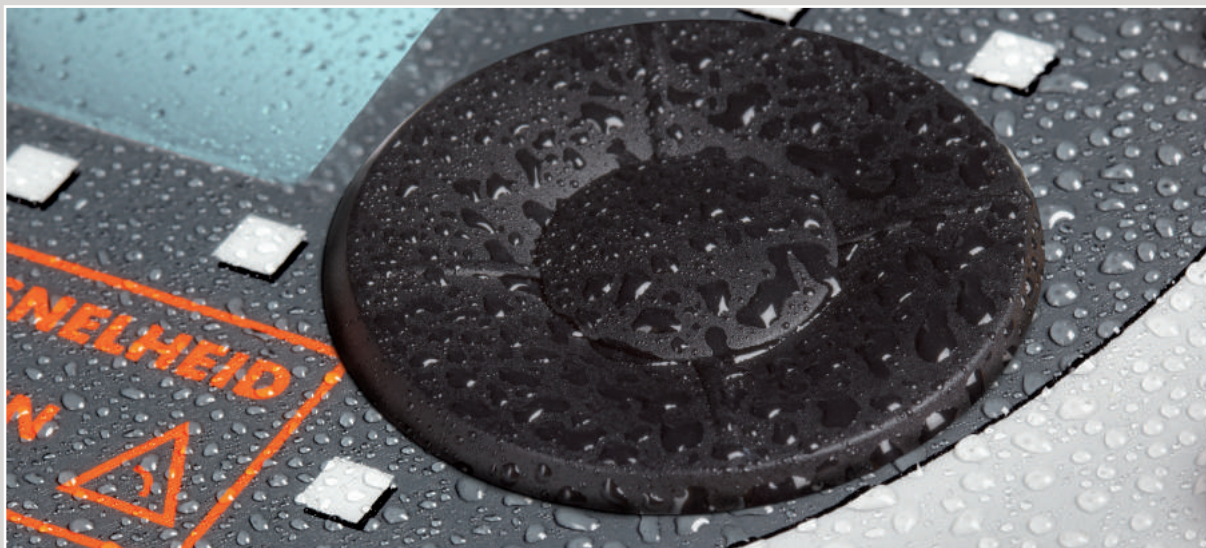

## PANEL SEALED SOLUTIONS



CONTROLMEC™ 1ZW

PANEL SEALED 1TS/1US/1VS

PANEL SEALED 10R & 10Q SERIES

AQUAMEC™

## CAPS FOR FOIL OVERLAY

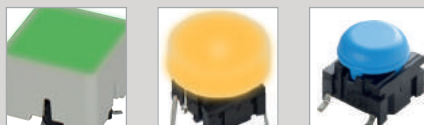

FOILMEC™ + 1GAS/1GCS + 1JS



- Rectangular caps
- Rocker-action pushbutton cap
- 12.5 mm x 10.1 mm; 18.65 mm x 10.1 mm; 25.0 mm x 10.1 mm
- h = 12.2 mm
- Material: ABS/polycarbonate
- Temp. Range:
  - Solid cap: -40/+65°C
  - Transparent cap: -40/+85°C
- Panel cut-out: 1A/1H-13.0 x 10.5, 1M-25.7 x 10.5, 1ZA-19.4x10.5

All dimensions in mm

Tolerances +/-0.2mm

### DIMENSIONS

#### SMD w/LED + 1A

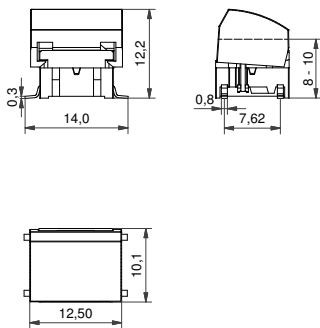

#### TH w/LED + 1H

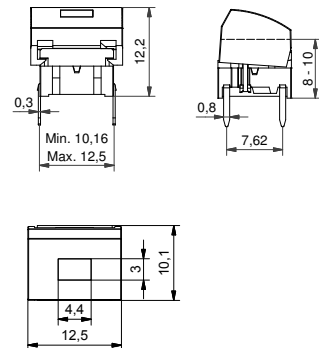

#### TH + 1ZA

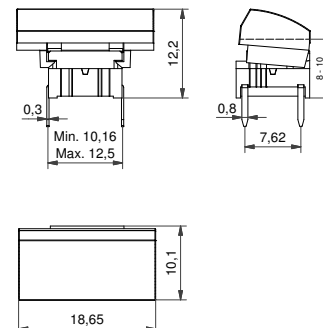

#### SMD + 1M

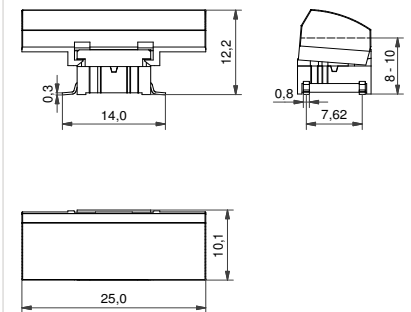

### ILLUMINATED – HOW TO ORDER

Switch	Mounting	Actuation force	LED	+	Cap	Colour code 1H	Lens 1H
<b>5 G</b>	<input type="checkbox"/> <input type="checkbox"/> <input type="checkbox"/>	<input type="checkbox"/> <input type="checkbox"/>	<input type="checkbox"/> <input type="checkbox"/> <input type="checkbox"/> <input type="checkbox"/>		<input type="checkbox"/> <input type="checkbox"/>	<input type="checkbox"/> <input type="checkbox"/>	<input type="checkbox"/>
	<b>TH9</b> through-hole <b>SH9</b> surface mount	<b>20</b> <b>35</b> <b>65</b> <b>Q*</b>	<b>02</b> blue <b>22</b> green <b>42</b> yellow <b>61</b> white <b>82</b> red <b>2242</b> green/yellow <b>8222</b> red/green <b>8242</b> red/yellow		<b>1H</b>  <b>1A</b> 	<b>03</b> grey <b>09</b> black  <u>Colour code 1A</u> <b>16</b> frosted white	<b>1</b> transparent <b>2</b> green <b>4</b> yellow <b>6</b> frosted white <b>8</b> red

\*For an illuminated quiet 2.0N switch add Q to the end of the switch part number.

### NON-ILLUMINATED – HOW TO ORDER

Switch	Mounting	Actuation force	+	Cap	Colour code 1A/1M	Colours 1ZA:
<b>5 G</b>	<input type="checkbox"/> <input type="checkbox"/> <input type="checkbox"/>	<input type="checkbox"/> <input type="checkbox"/>		<input type="checkbox"/> <input type="checkbox"/> <input type="checkbox"/>	<input type="checkbox"/> <input type="checkbox"/>	
	<b>TH9</b> through-hole <b>SH9</b> surface mount	<b>20</b> <b>20Q</b> <b>35</b> <b>65</b>		<b>1A</b>  <b>1ZA</b>  <b>1M</b> 	<b>00</b> blue <b>02</b> green <b>03</b> grey <b>04</b> yellow <b>06</b> white <b>08</b> red <b>09</b> black	<b>03</b> grey <b>06</b> white <b>09</b> black <b>30</b> ultra blue <b>40</b> dusty blue <b>42</b> aqua blue <b>50</b> metal dark blue <b>53</b> metal light grey <b>57</b> metal dark grey <b>58</b> metal bordeaux

Ordering example:

5GSH93582 + 1H098 with illumination OR 5GTH965 + 1ZA57 without illumination OR \*5GTH92001Q (illuminated quiet version).

Please see colour codes, updates of products and changes of specifications on [www.apem.com](http://www.apem.com)

- Rectangular caps; square solution
- Rocker-action pushbutton cap
- 15.1 mm x 15.1 mm
- h = 12.2 mm
- Material: ABS/polycarbonate
- Temp. Range:
  - Solid cap and bezel: -40/+65°C
  - Transparent cap: -40/+85°C
- Panel cut-out: 1B/1C+2C/2D-15.5 x 15.5



All dimensions in mm

Tolerances +/-0.2mm

### DIMENSIONS

#### SMD 1B+2D

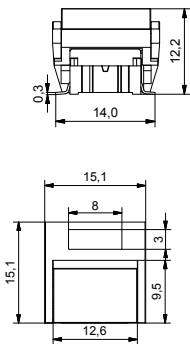

#### TH 1B+2C

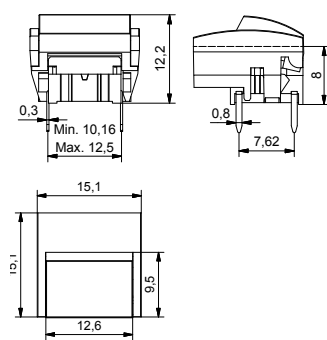

#### TH w/LED 1C+2C

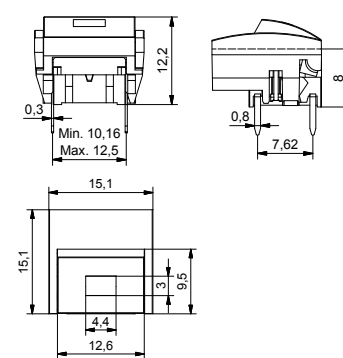

#### SMD w/LED 1B+2D

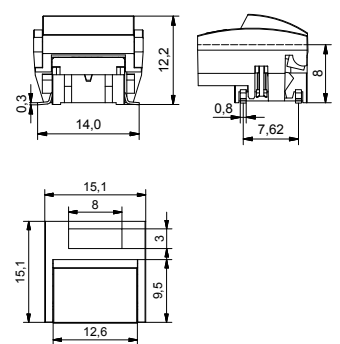

### ILLUMINATED – HOW TO ORDER

Switch	Mounting	Actuation force	LED	Cap	Bezel
<b>5 G</b>	<input type="checkbox"/> <input type="checkbox"/> <input type="checkbox"/>	<input type="checkbox"/> <input type="checkbox"/>	<input type="checkbox"/> <input type="checkbox"/> <input type="checkbox"/>	<b>1 C</b> <input type="checkbox"/> <input type="checkbox"/> <input type="checkbox"/>	<b>2 C</b> <input type="checkbox"/> <input type="checkbox"/>
	<b>TH9</b> through-hole	<b>20</b>	<b>02</b> blue	Solid colour	Colour code
	<b>SH9</b> surface mount	<b>35</b>	<b>22</b> green		
		<b>65</b>	<b>42</b> yellow	<b>1 B</b> <input type="checkbox"/> <input type="checkbox"/>	<b>2 D</b> <input type="checkbox"/> <input type="checkbox"/> <input type="checkbox"/>
		<b>Q*</b>	<b>61</b> white	Transparent	Colour code <input type="checkbox"/> Lens
			<b>82</b> red		
			<b>2242</b> green/yellow		
			<b>8222</b> red/green		
			<b>8242</b> red/yellow		

\*For an illuminated quiet 2.0N switch add Q to the end of the switch part number.

### NON-ILLUMINATED – HOW TO ORDER

Switch	Mounting	Actuation force	Cap	Bezel
<b>5 G</b>	<input type="checkbox"/> <input type="checkbox"/> <input type="checkbox"/>	<input type="checkbox"/> <input type="checkbox"/>	<b>1 B</b> <input type="checkbox"/> <input type="checkbox"/>	<b>2 C</b> <input type="checkbox"/> <input type="checkbox"/> <b>OR</b> <b>2 D</b> <input type="checkbox"/> <input type="checkbox"/> <input type="checkbox"/>
	<b>TH9</b> through-hole	<b>20</b>	Solid colour	Colour code
	<b>SH9</b> surface mount	<b>20Q</b>		
		<b>35</b>		
		<b>65</b>		

### COLOUR CODES

Transparent caps	Solid caps 1B	Solid caps 1C	Solid colours 2C & 2D:	Lenses
<b>16</b> frosted white	<b>00</b> blue	<b>03</b> grey	<b>00</b> blue	<b>1</b> transparent
	<b>02</b> green	<b>08</b> red	<b>03</b> grey	<b>2</b> green
	<b>03</b> grey	<b>09</b> black	<b>06</b> white	<b>4</b> yellow
	<b>04</b> yellow		<b>08</b> red	<b>6</b> frosted white
			<b>09</b> black	<b>8</b> red

Ordering example:  
 5GTH93561+1C031+2C09 with illumination OR 5GSH965+1B08+2D081 without illumination OR \*5GSH92001Q (illuminated quiet version)  
 Please see colour codes, updates of products and changes of specifications on [www.apem.com](http://www.apem.com)



- Round caps
- Ø9.6 mm
- h =14.9 mm
- Material: ABS/polycarbonate
- Temp. Range:
  - Solid cap: -40/+65°C
  - Transparent cap :-40/+85°C
- Panel cut-out: 1DS/1ES/1FS-Ø10.0

All dimensions in mm

Tolerances -/+0.2mm

### DIMENSIONS

#### TH + 1DS

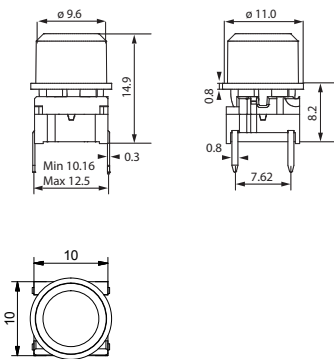

#### SMD w/LED + 1ES

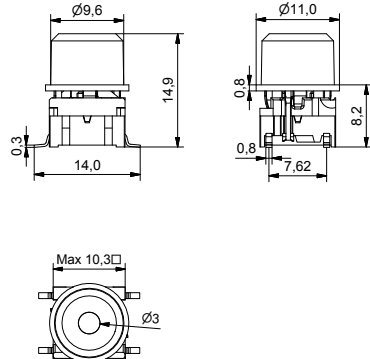

#### TH w/LED + 1FS

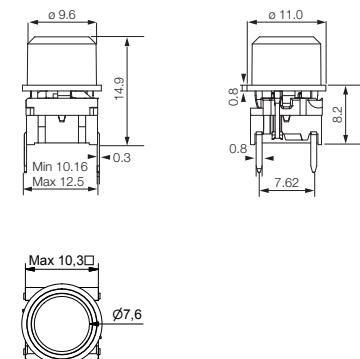

### ILLUMINATED – HOW TO ORDER

Switch	Mounting	Actuation force	LED	+	Cap	Colour code	Lens
<b>5 G</b>	<input type="checkbox"/> <input type="checkbox"/> <input type="checkbox"/>	<input type="checkbox"/> <input type="checkbox"/>	<input type="checkbox"/> <input type="checkbox"/> <input type="checkbox"/>		<input type="checkbox"/> <input type="checkbox"/> <input type="checkbox"/>	<input type="checkbox"/> <input type="checkbox"/>	<input type="checkbox"/>
	<b>TH9</b> through-hole <b>SH9</b> surface mount	<b>20</b> <b>35</b> <b>65</b> <b>Q*</b>	<b>02</b> blue <b>22</b> green <b>42</b> yellow <b>61</b> white <b>82</b> red <b>2242</b> green/yellow <b>8222</b> red/green <b>8242</b> red/yellow		<b>1ES</b>  <b>1FS</b> 	<b>00</b> blue <b>02</b> green <b>03</b> grey <b>04</b> yellow <b>06</b> white <b>08</b> red <b>09</b> black	<b>1</b> transparent <b>2</b> green <b>4</b> yellow <b>6</b> frosted white <b>8</b> red
					<b>1DS</b> 	<b>11</b> transparent <b>16</b> frosted white	

\*For an illuminated quiet 2.0N switch add Q to the end of the switch part number.

### NON-ILLUMINATED – HOW TO ORDER

Switch	Mounting	Actuation force	+	Cap	Colour code
<b>5 G</b>	<input type="checkbox"/> <input type="checkbox"/> <input type="checkbox"/>	<input type="checkbox"/> <input type="checkbox"/> <input type="checkbox"/>		<input type="checkbox"/> <input type="checkbox"/> <input type="checkbox"/>	<input type="checkbox"/> <input type="checkbox"/>
	<b>TH9</b> through-hole <b>SH9</b> surface mount	<b>20</b> <b>20Q</b> <b>35</b> <b>65</b>		<b>1DS</b> 	<b>00</b> blue <b>02</b> green <b>03</b> grey <b>04</b> yellow <b>06</b> white <b>08</b> red <b>09</b> black
					<b>30</b> ultra blue <b>40</b> dusty blue <b>42</b> aqua blue <b>32</b> mint green <b>33</b> tele grey <b>34</b> melon <b>38</b> noble red
					<b>50</b> metal dark blue <b>53</b> metal light grey <b>57</b> metal dark grey <b>58</b> metal bordeaux

Ordering example:  
5GTH935+1DS06 without illumination OR 5GSH96561+1FS096R13509 with illumination OR \*5GSH92042Q (illuminated quiet version)  
Please see colour codes, updates of products and changes of specifications on [www.apem.com](http://www.apem.com)

- Round caps
- Excellent option for foil overlay
- Ø11 mm; Ø15 mm
- h = 12.5 mm
- Material: polyamide
- Temp. Range:
  - Solid cap: -40/+160°C
  - Transparent cap: -40/+85°C
- Panel cut-out: 1GAS/1GCS-Ø11.4; Ø15.4

All dimensions in mm

Tolerances +/-0.2mm



## DIMENSIONS

### SMD + 1GAS

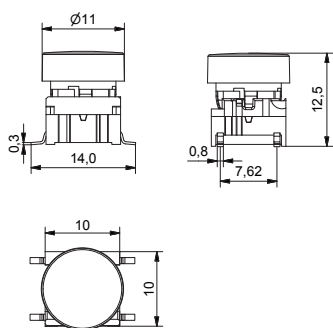

### SMD w/LED + 1GAS

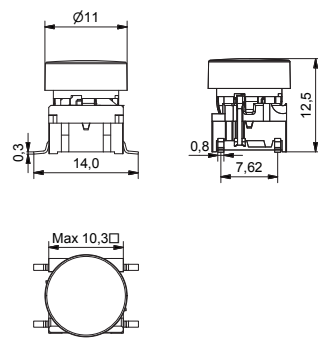

### TH + 1GCS

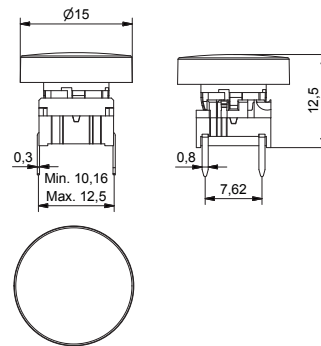

### TH w/LED + 1GCS

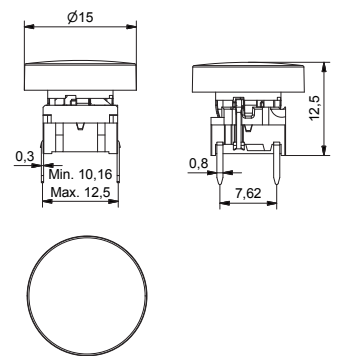

## ILLUMINATED – HOW TO ORDER

Switch	Mounting	Actuation force	LED	+	Cap transparent colour	Colour code
5 G	TH9 through-hole SH9 surface mount	20 35 65 Q*	02 blue 22 green 42 yellow 61 white 82 red 2242 green/yellow 8222 red/green 8242 red/yellow		1GAS 1GCS	11 transparent 16 frosted white

\*For an illuminated quiet 2.0N switch add Q to the end of the switch part number.

## NON-ILLUMINATED – HOW TO ORDER

Switch	Mounting	Actuation force	+	Cap solid colour	Colour code
5 G	TH9 through-hole SH9 surface mount	20 20Q 35 65		1GAS 1GCS	00 blue 02 green 03 grey 04 yellow 06 white 08 red 09 black

Ordering example:  
5GSH935 + 1GAS09 without illumination OR 5GTH96502 + 1GCS16 with illumination OR \*5GTH92061Q (illuminated quiet version)  
Please see colour codes, updates of products and changes of specifications on [www.apem.com](http://www.apem.com)



- Round cap
- Ø9.6 mm
- h =10.4 mm
- Material: ABS/polycarbonate
- Temp. Range:
  - Solid cap: -40/+65°C
  - Transparent cap: -40/+85°C
- Panel cut-out: 1JS-Ø10.4

\*Legends on the picture are custom

All dimensions in mm

Tolerances +/-0.2mm

## DIMENSIONS

### TH + 1JS

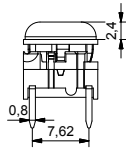
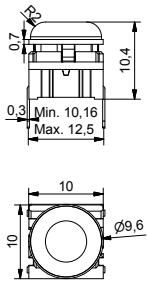

### SMD w/LED + 1JS

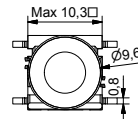
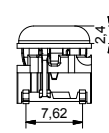
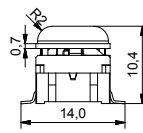

## ILLUMINATED – HOW TO ORDER

Switch	Mounting	Actuation force	LED		Cap transparent	Colour code
<b>5 G</b>	<input type="checkbox"/> <input type="checkbox"/> <input type="checkbox"/>	<input type="checkbox"/> <input type="checkbox"/>	<input type="checkbox"/> <input type="checkbox"/> <input type="checkbox"/> <input type="checkbox"/>	<b>+</b>	<b>1 J S</b>	<input type="checkbox"/> <input type="checkbox"/>
	<b>TH9</b> through-hole <b>SH9</b> surface mount	<b>20</b> <b>35</b> <b>65</b> <b>Q*</b>	<b>02</b> blue <b>22</b> green <b>42</b> yellow <b>61</b> white <b>82</b> red <b>2242</b> green/yellow <b>8222</b> red/green <b>8242</b> red/yellow			<b>11</b> transparent <b>16</b> frosted white

## NON-ILLUMINATED – HOW TO ORDER

Switch	Mounting	Actuation force		Cap solid colour	Colour code
<b>5 G</b>	<input type="checkbox"/> <input type="checkbox"/> <input type="checkbox"/>	<input type="checkbox"/> <input type="checkbox"/>	<b>+</b>	<b>1 J S</b>	<input type="checkbox"/> <input type="checkbox"/>
	<b>TH9</b> through-hole <b>SH9</b> surface mount	<b>20</b> <b>20Q</b> <b>35</b> <b>65</b>			<b>00</b> blue <b>02</b> green <b>03</b> grey <b>04</b> yellow <b>06</b> white <b>08</b> red <b>09</b> black

Ordering example:  
5GTH935+1JS08 without illumination OR 5GTH93501+1JS16 with illumination OR \*5GTH92001Q (illuminated quiet version)  
Please see colour codes, updates of products and changes of specifications on [www.apem.com](http://www.apem.com)

- Square caps
- Different top surfaces: flat, convex or concave
- 14.3 mm x 14.3 mm
- h = 19.1 mm; 20.2 mm; 20.1 mm
- Material: ABS/polycarbonate
- Temp. Range:
  - Solid cap: -40/+65°C
  - Transparent cap: -40/+85°C
- Panel cut-out: 1KS/1KBS/1KCS-14.7 x 14.7



All dimensions in mm

Tolerances +/-0.2mm

Custom solution

### DIMENSIONS

#### SMD w/LED + 1KS

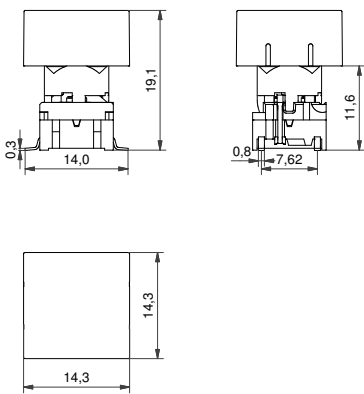

#### TH w/LED + 1KBS

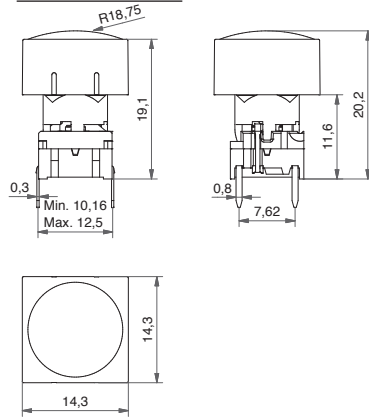

#### SMD w/LED + 1KCS

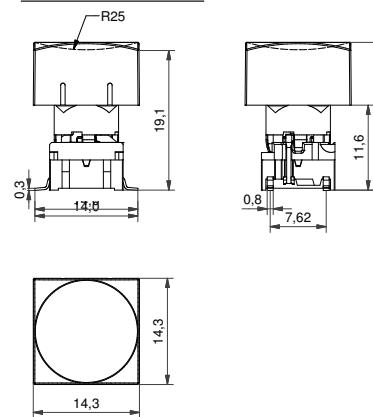

#### Bezel (optional)

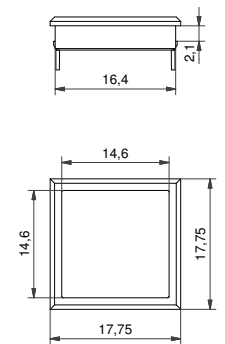

### ILLUMINATED – HOW TO ORDER

Switch	Mounting	Actuation force	LED	+	Cap	+	Bezel
5 G	TH9 through-hole SH9 surface mount	20 35 65 Q*	02 blue 22 green 42 yellow 61 white 82 red 2242 green/yellow 8222 red/green 8242 red/yellow		1 1 1 6 Frosted white lens and transparent lid		2 K 03 grey 06 white 08 red 09 black
					1KS 1KCS 1KBS		

\*For an illuminated quiet 2.0N switch add Q to the end of the switch part number.

### NON-ILLUMINATED – HOW TO ORDER

Switch	Mounting	Actuation force	+	Cap	+	Bezel
5 G	TH9 through-hole SH9 surface mount	20 20Q 35 65		1 K S 1 6 Frosted white lens		2 K 03 grey 06 white 08 red 09 black
				1KS		

Ordering example:

5GTH93501+1KCS11116+2K09 with illumination OR 5GSH965+1KS0916+2K03 without illumination OR \*5GTH92082Q (illuminated quiet version)

Please see colour codes, updates of products and changes of specifications on [www.apem.com](http://www.apem.com)



- Teardrop-shaped cap
- Ø9.6 mm; □ = 4.9 mm
- h = 14.9 mm
- Material: ABS/polycarbonate
- Temp. Range:
  - Solid cap: -40/+65°C
  - Transparent cap: -40/+85°C
- Panel cut-out: 1NS-Ø10.2/ □ = 5.1

All dimensions in mm

Tolerances +/-0.2mm

## DIMENSIONS

### SMD + 1NS

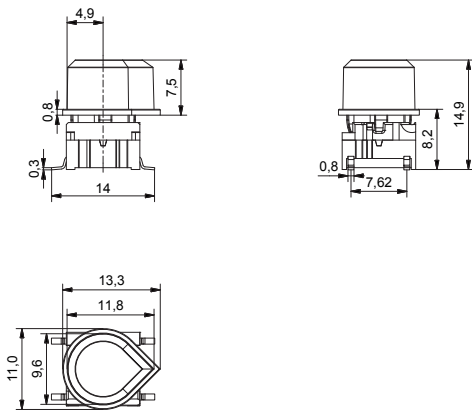

### TH w/LED + 1NS

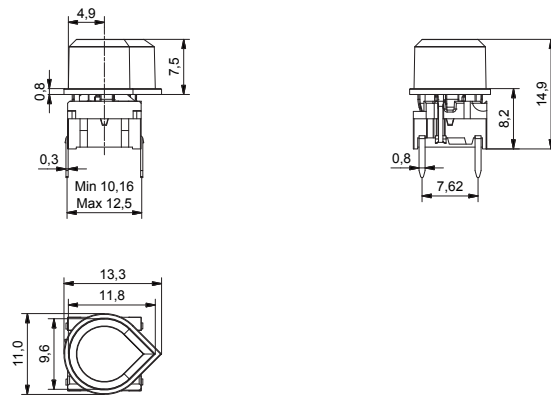

## ILLUMINATED – HOW TO ORDER

Switch	Mounting	Actuation force	LED	+	Cap transparent	Colour code
<b>5 G</b>	<input type="checkbox"/> <input type="checkbox"/> <input type="checkbox"/>	<input type="checkbox"/> <input type="checkbox"/> <input type="checkbox"/>	<input type="checkbox"/> <input type="checkbox"/> <input type="checkbox"/> <input type="checkbox"/> <input type="checkbox"/>		<b>1 N S</b>	<input type="checkbox"/> <input type="checkbox"/>
	<b>TH9</b> through-hole <b>SH9</b> surface mount	<b>20</b> <b>35</b> <b>65</b> <b>Q*</b>	<b>02</b> blue <b>22</b> green <b>42</b> yellow <b>61</b> white <b>82</b> red <b>2242</b> green/yellow <b>8222</b> red/green <b>8242</b> red/yellow			<b>16</b> frosted white

\*For an illuminated quiet 2.0N switch add Q to the end of the switch part number.

## NON-ILLUMINATED – HOW TO ORDER

Switch	Mounting	Actuation force	+	Cap	Colour code
<b>5 G</b>	<input type="checkbox"/> <input type="checkbox"/> <input type="checkbox"/>	<input type="checkbox"/> <input type="checkbox"/> <input type="checkbox"/>		<b>1 N S</b>	<input type="checkbox"/> <input type="checkbox"/>
	<b>TH9</b> through-hole <b>SH9</b> surface mount	<b>20</b> <b>20Q</b> <b>35</b> <b>65</b>			<b>03</b> grey <b>09</b> black

Ordering example:  
5GSH965+1NS09 non-illuminated OR 5GTH93502+1NS16 with illumination OR \*5GTH92082Q (illuminated quiet version)  
Please see colour codes, updates of products and changes of specifications on [www.apem.com](http://www.apem.com)

- Rectangular caps
- Concave top surface
- 12.5 mm x 6.5 mm
- h = 15.7 mm
- Material: ABS/polycarbonate
- Temp. Range:
  - Solid cap: -40/+65°C
  - Transparent cap: -40/+85°C
- Panel cut-out: 1PS/1QS/1RS-7.0 x 13.0, R max. 1.0

All dimensions in mm

Tolerances +/-0.2mm

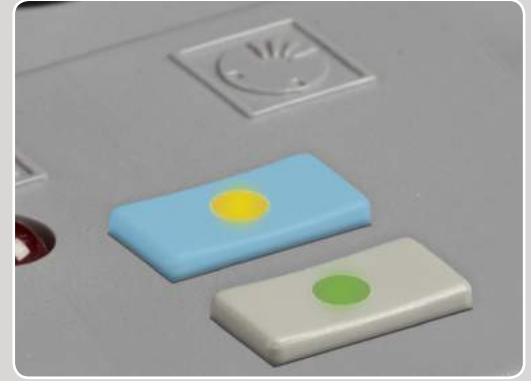

### DIMENSIONS

#### SMD (5E) + 1PS

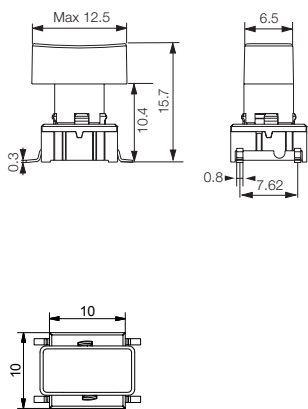

#### TH w/LED (5G) + 1RS

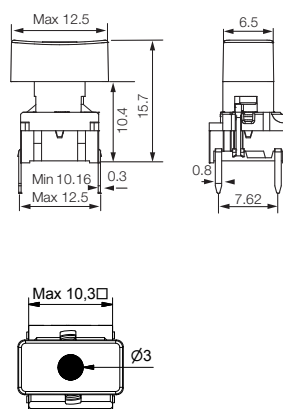

#### TH w/LED (5G) + 1QS

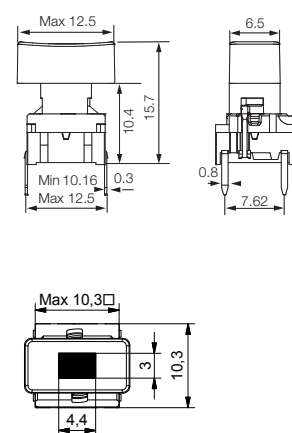

### ILLUMINATED – HOW TO ORDER

Switch	Mounting	Actuation force	LED	+	Cap	Colour code	Lens
<b>5 G</b>	<input type="checkbox"/> <input type="checkbox"/> <input type="checkbox"/>	<input type="checkbox"/> <input type="checkbox"/>	<input type="checkbox"/> <input type="checkbox"/> <input type="checkbox"/> <input type="checkbox"/>		<input type="checkbox"/> <input type="checkbox"/> <input type="checkbox"/>	<input type="checkbox"/> <input type="checkbox"/>	<input type="checkbox"/>
	<b>TH9</b> through-hole	<b>20</b>	<b>02</b> blue		<b>1QS</b>	<b>00</b> blue	<b>1</b> transparent
	<b>SH9</b> surface mount	<b>35</b>	<b>22</b> green			<b>03</b> grey	<b>6</b> frosted white
		<b>65</b>	<b>42</b> yellow		<b>1RS</b>	<b>09</b> black	
		<b>Q*</b>	<b>61</b> white				
			<b>82</b> red				
			<b>2242</b> green/yellow				
			<b>8222</b> red/green				
			<b>8242</b> red/yellow				
					<b>1PS</b>	<b>11</b> transparent	
						<b>16</b> frosted white	

\*For an illuminated quiet 2.0N switch add Q to the end of the switch part number.

### NON-ILLUMINATED – HOW TO ORDER

Switch	Mounting	Actuation force	+	Cap	Colour code
<b>5 E</b>	<input type="checkbox"/> <input type="checkbox"/> <input type="checkbox"/>	<input type="checkbox"/> <input type="checkbox"/> <input type="checkbox"/>		<input type="checkbox"/> <input type="checkbox"/> <input type="checkbox"/>	<input type="checkbox"/> <input type="checkbox"/>
<b>5 G</b>	<b>TH9</b> through-hole	<b>20</b>		<b>1PS</b>	<b>00</b> blue
	<b>SH9</b> surface mount	<b>20Q</b>			<b>02</b> green
		<b>35</b>			<b>03</b> grey
		<b>65</b>			<b>04</b> yellow
					<b>06</b> white
					<b>08</b> red
					<b>09</b> black

Ordering example:

5GTH935+1PS08 without illumination OR 5GSH96542+1RS001 with illumination OR \*5GSH92061Q (illuminated quiet version)

Please see colour codes, updates of products and changes of specifications on [www.apem.com](http://www.apem.com)



- Round caps
- 9 standard options in overall height
- Ø6.5 mm
- h = 8-22.5 mm; 10.4-22.5 mm; 12-22.5 mm
- Material: polyamide
- Temp. Range:
  - Solid cap: -40/+160°C (1SS); -40/+65°C (1LS)
  - Transparent cap: -40/+85°C
- Panel cut-out: 1SS/1LS/1IS-Ø7.0

All dimensions in mm

Tolerances +/-0.2mm

## DIMENSIONS

### SMD (5E) + 1SS

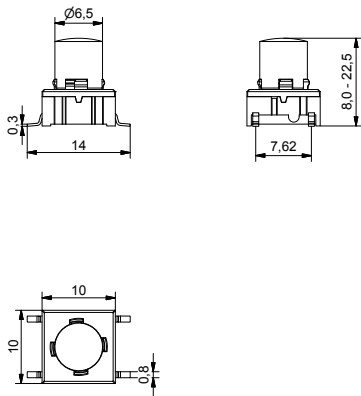

### TH w/LED (5G) + 1LS

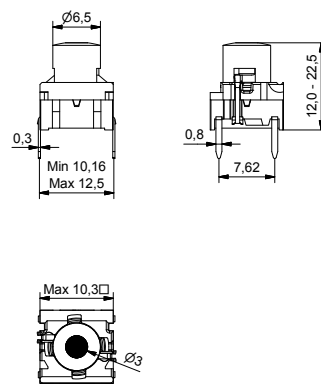

### SMD w/LED (5G) + 1IS

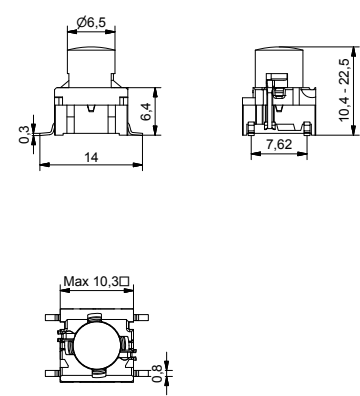

## ILLUMINATED – HOW TO ORDER

Switch	Mounting	Actuation force	LED	Cap	Colour code	Lens	Height 1LS
5 G	TH9 through-hole SH9 surface mount	20 35 65 Q*	02 blue 22 green 42 yellow 61 white 82 red 2242 green/yellow 8222 red/green 8242 red/yellow	1LS with lens 1IS fully illuminated	00 blue 02 green 03 grey 04 yellow 06 white 08 red 09 black 11 transparent 16 frosted white	1 transparent 2 green 4 yellow 6 frosted white 8 red	12.0 19.0 15.0 22.5 16.0 Height 1IS 10.4 16.0 11.0 19.0 12.0 22.5 15.0

\*For an illuminated quiet 2.0N switch add Q to the end of the switch part number.

## NON-ILLUMINATED – HOW TO ORDER

Switch	Mounting	Actuation force	Cap	Colour code	Height
5 E	TH9 through-hole SH9 surface mount	20 20Q 35 65	1SS solid colour	00 blue 02 green 03 grey 04 yellow 06 white 08 red 09 black	08.0 16.0 09.5 19.0 10.4 22.5 11.0 12.0 15.0

Ordering example:

5ETH920+1SS04-09.5 without illumination OR 5GSH93542+1IS16-19.0 with illumination OR \*5GTH9208222Q (illuminated quiet version)

Please see colour codes, updates of products and changes of specifications on [www.apem.com](http://www.apem.com)

- Square, round and half-ellipse shaped caps
- Rounded top surface
- Option to have it panel sealed
  - IP65 = 5G+1TS+1TW
  - IP67 = 5G+1US+1UW
  - IP65 = 5G+1VS+1VW
- 10.6 mm x 10.6 mm; Ø10.6 mm; 10.6 mm x 13.25 mm
- h =14.9 mm
- Material: ABS/polycarbonate (cap); silicone rubber (sealing)
- Temp. Range:
  - Solid cap: -40/+65°C
  - Transparent cap: -40/+85°C
  - Panel cut-out: 1TS-11.0 x 11.0, 1US-Ø11.0, 1VS-11.0 x 13.65

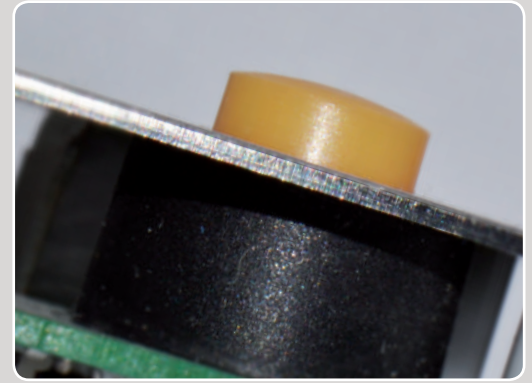

All dimensions in mm

Tolerances +/-0.2mm

### DIMENSIONS

#### TH + 1TS+1TW

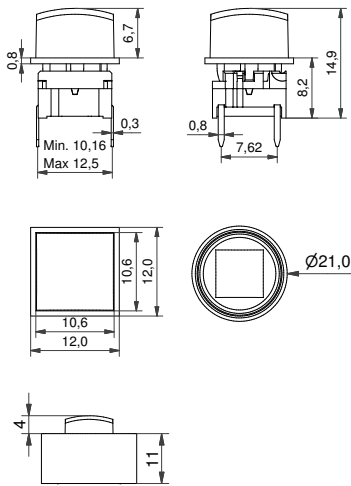

#### TH w/LED + 1US+1UW

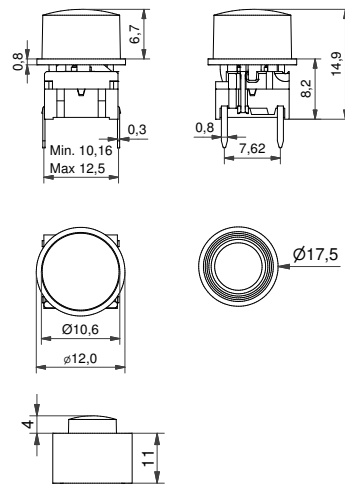

#### SMD + 1VS+1VW

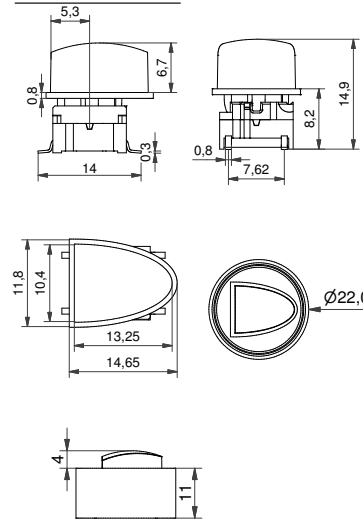

### PANEL CUT-OUT

#### Recommended

- 1TS - 11x11 mm
- 1US - Ø11 mm
- 1VS

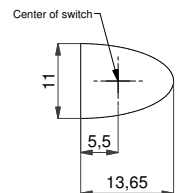

\*mathematical shape of half-ellipse

Distance between PCB and front panel

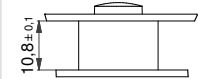

### ILLUMINATED – HOW TO ORDER

Switch	Mounting	Actuation force	LED	+	Cap	Colour code	+	Sealing
5 G	TH9 through-hole SH9 surface mount	20 35 65 Q*	02 blue 22 green 42 yellow 61 white 82 red 2242 green/yellow 8222 red/green 8242 red/yellow		1TS 1US	16 frosted white		1TW 1UW 1VW

\*For an illuminated quiet 2.0N switch add Q to the end of the switch part number.

### NON-ILLUMINATED – HOW TO ORDER

Switch	Mounting	Actuation force	+	Cap	Colour code	+	Sealing
5 G	TH9 through-hole SH9 surface mount	20 20Q 35 65		1TS 1US	00 blue 03 grey 08 red 09 black		1TW 1UW 1VW

Ordering example:

5GSH935 + 1TS03 + 1TW without illumination OR 5GTH96542 + 1US16 + 1UW with illumination OR \*5GTH92082Q (illuminated quiet version)

Please see colour codes, updates of products and changes of specifications on [www.apem.com](http://www.apem.com)



- Ellipse-shaped caps
- Convex or concave top surface
- 6.5 mm x 12.5 mm; 8.0 mm x 15.2 mm
- h = 15.7 mm
- Material: ABS/polycarbonate
- Temp. Range:
  - Solid cap: -40/+65°C
  - Transparent cap: -40/+85°C
- Panel cut-out: 1WAS/1WPS-12.9x6.9, 1WDS-15.6x8.4

All dimensions in mm

Tolerances +/-0.2mm

### DIMENSIONS

#### SMD + 1WAS

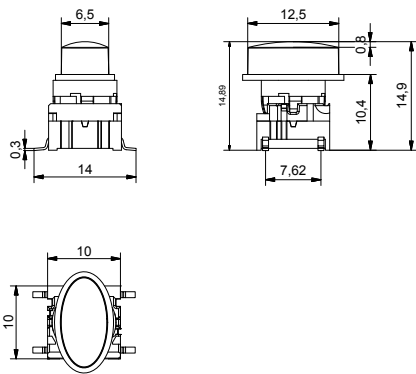

#### TH w/LED + 1WPS

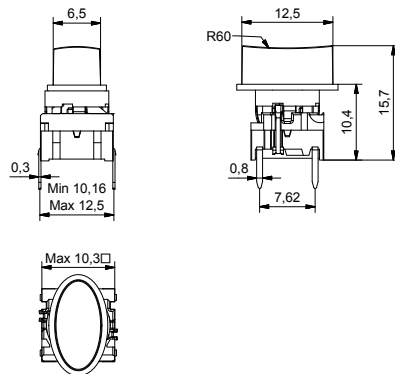

#### TH + 1WDS

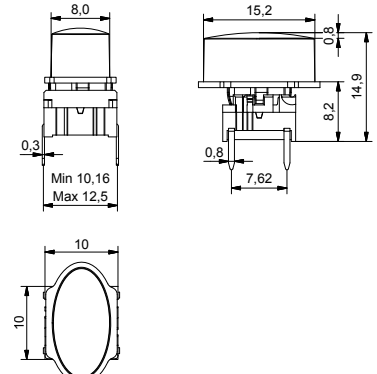

### ILLUMINATED – HOW TO ORDER

Switch	Mounting	Actuation force	LED	+	Cap	Colour code
5 G	<input type="checkbox"/> <input type="checkbox"/> <input type="checkbox"/>	<input type="checkbox"/> <input type="checkbox"/>	<input type="checkbox"/> <input type="checkbox"/> <input type="checkbox"/> <input type="checkbox"/>		<input type="checkbox"/> <input type="checkbox"/> <input type="checkbox"/> <input type="checkbox"/>	<input type="checkbox"/> <input type="checkbox"/>
	TH9 through-hole SH9 surface mount	20 35 65 Q*	02 blue 22 green 42 yellow 61 white 82 red 2242 green/yellow 8222 red/green 8242 red/yellow		1WAS  1WPS 	1WDS  16 frosted white

\*For an illuminated quiet 2.0N switch add Q to the end of the switch part number.

### NON-ILLUMINATED – HOW TO ORDER

Switch	Mounting	Actuation force	+	Cap	Colour code
5 G	<input type="checkbox"/> <input type="checkbox"/> <input type="checkbox"/>	<input type="checkbox"/> <input type="checkbox"/>		<input type="checkbox"/> <input type="checkbox"/> <input type="checkbox"/> <input type="checkbox"/>	<input type="checkbox"/> <input type="checkbox"/>
	TH9 through-hole SH9 surface mount	20 20Q 35 65		1WAS  1WPS 	1WDS  00 blue 03 grey 08 red 09 black 30 ultra blue 40 dusty blue 42 aqua blue 53 metal light grey 57 metal dark grey

Ordering example:  
5GTH935+1WAS00 without illumination OR 5GSH96582+1WDS16 with illumination OR \*5GSH92042Q (illuminated quiet version)  
Please see colour codes, updates of products and changes of specifications on [www.apem.com](http://www.apem.com)

- Rectangular cap
- 7.4 mm x 9.4 mm
- h = 18.5 mm
- Material: ABS/polycarbonate
- Temp. Range:
  - Solid cap: -40/+65°C
  - Transparent cap: -40/+85°C
- Panel cut-out: 1XS-9.8 x 7.9



All dimensions in mm

Tolerances -/+0.2mm

### DIMENSIONS

#### TH + 1XS

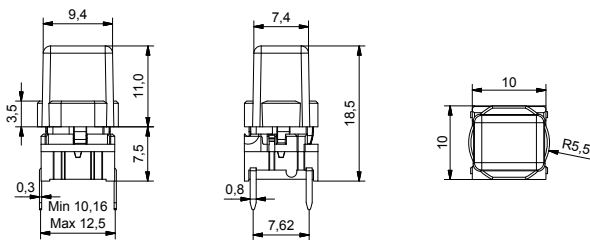

#### SMD w/LED + 1XS

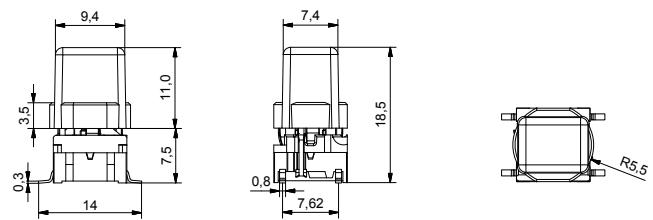

### ILLUMINATED – HOW TO ORDER

Switch	Mounting	Actuation force	LED	+	Cap	Colour code
5 G	<input type="checkbox"/> <input type="checkbox"/> <input type="checkbox"/>	<input type="checkbox"/> <input type="checkbox"/> <input type="checkbox"/>	<input type="checkbox"/> <input type="checkbox"/> <input type="checkbox"/> <input type="checkbox"/>		1 X S	<input type="checkbox"/> <input type="checkbox"/>
	TH9 through-hole SH9 surface mount	20 35 65 Q*	02 blue 22 green 42 yellow 61 white 82 red 2242 green/yellow 8222 red/green 8242 red/yellow			11 transparent 16 frosted white

### NON-ILLUMINATED – HOW TO ORDER

Switch	Mounting	Actuation force	+	Cap	Colour code
5 G	<input type="checkbox"/> <input type="checkbox"/> <input type="checkbox"/>	<input type="checkbox"/> <input type="checkbox"/> <input type="checkbox"/>		1 X S	<input type="checkbox"/> <input type="checkbox"/>
	TH9 through-hole SH9 surface moun	20 20Q 35 65			00 blue 02 green 03 grey 04 yellow 06 white 08 red 09 black

Ordering example:

5GTH9352242+1XS16 with illumination OR 5GSH965+1XS02 non-illuminated OR \*5GTH9208242Q (illuminated quiet version)

Please see colour codes, updates of products and changes of specifications on [www.apem.com](http://www.apem.com)



- Square cap
- Designed for foil overlay
- 15 mm x 15 mm
- h = 12.5 mm
- Material: ABS/polycarbonate
- Temp. Range: -40/+65°C
- Panel cut-out: 1YS-16 x 16

All dimensions in mm

Tolerances +/-0.2mm

## DIMENSIONS

### TH + 1YS

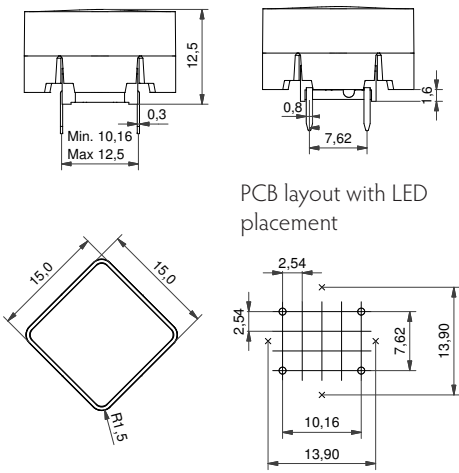

### SMD + 1YS

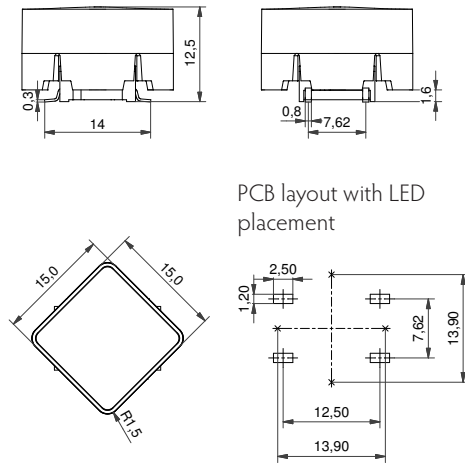

## RECOMMENDED PLACEMENT OF LEDs

### SMD

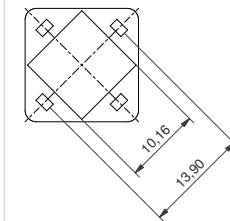

### TH

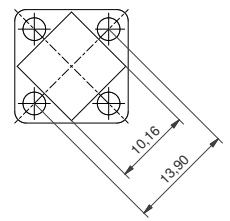

LED Recommendation  
 SMD: 1206 - 0805 - 0603 - 0402  
 TH: 3 mm - Ø max 3.2 - Height max 6.5 mm

## HOW TO ORDER

Switch  
**5 E**

Mounting

Actuation force

+

Cap  
**1 Y S 0 6 1 6**

**TH9** through-hole  
**SH9** surface mount

**20**  
**20Q**  
**35**  
**65**

**1YS0616** white cap with frosted white lens

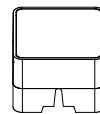

A: We recommend you to allocate enough space for travel of the foil and leave the area free from adhesive. Switch travel = 1 mm.

H: The height recommendation does not include the foil. We recommend embossing the foil to follow the curve of the keycap.

The best tactile feeling is obtained with a small pretravel.

The dimension H is based on an embossed foil. With a flat foil the dimension "H" will have to be adjusted, and enough area between the cap and front panel needs to be addressed to ensure foil flexibility.

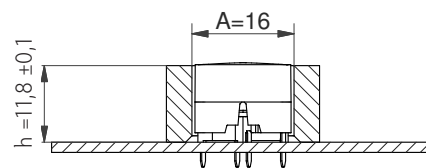

Ordering example: 5ESH935+1YS0616

Please see colour codes, updates of products and changes of specifications on [www.apem.com](http://www.apem.com)

- Round solution
- Designed for navigating a display or controlling a unit
- 90° R=17.5 mm; Ø14.3 mm (Ø34.25 mm)
- h =12.2 mm; 11.7 mm
- Material: ABS/polycarbonate
- Temp. Range:
  - Solid cap: -40/+65°C
  - Transparent cap: -40/+85°C
- Panel cut-out: 1ZB-R<sub>1</sub> 7,1 R<sub>2</sub> 17,5 – 17,75 90° 1ZCS-Ø14.7
- navimec™ panel cut-out: Ø35,0 - 35,5 Depending on application

All dimensions in mm

Tolerances +/-0.2mm



### DIMENSIONS

#### TH + 1ZB

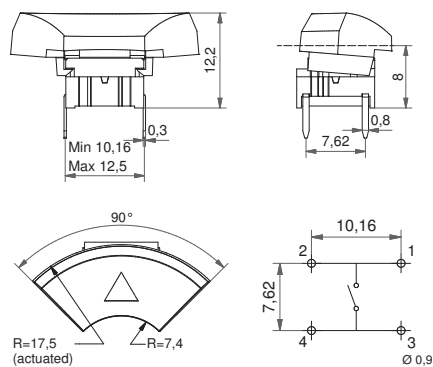

#### SMD w/LED + 1ZCS

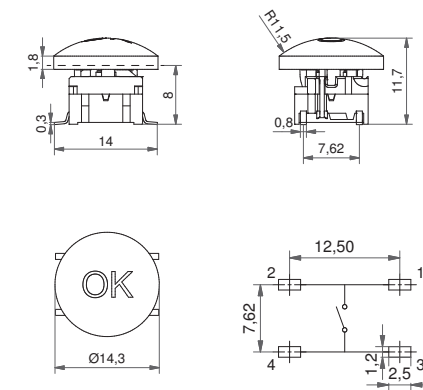

#### PCB layout for Navimec solution

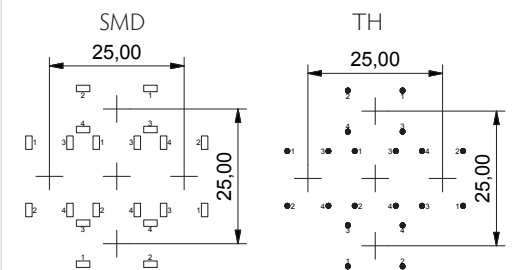

We recommend using through-hole terminals for precise placing.

### ILLUMINATED – HOW TO ORDER

Switch	Mounting	Actuation force	LED	+	Cap	Legend code
5 G	<input type="checkbox"/> <input type="checkbox"/> <input type="checkbox"/>	<input type="checkbox"/> <input type="checkbox"/>	<input type="checkbox"/> <input type="checkbox"/> <input type="checkbox"/> <input type="checkbox"/>	<input type="checkbox"/>	1 Z B 1 6	<input type="checkbox"/> <input type="checkbox"/> <input type="checkbox"/>
	TH9 through-hole (SH9 surface mount)	20 35 65 Q*	02 blue 22 green 42 yellow 61 white 82 red 2242 green/yellow 8222 red/green 8242 red/yellow		Frosted white with black hard paint and laser marking	DLMH136 ▲
						<input type="checkbox"/> <input type="checkbox"/> <input type="checkbox"/>
					1 Z C S 1 6	LMH118 OK LMH123 ⏻

\*For an illuminated quiet 2.0N switch add Q to the end of the switch part number.

### NON-ILLUMINATED – HOW TO ORDER

Switch	Mounting	Actuation force	+	Cap	Colour code	Legend code**
5 G	<input type="checkbox"/> <input type="checkbox"/> <input type="checkbox"/>	<input type="checkbox"/> <input type="checkbox"/>	<input type="checkbox"/>	1 Z B	<input type="checkbox"/> <input type="checkbox"/>	<input type="checkbox"/> <input type="checkbox"/> <input type="checkbox"/>
	TH9 through-hole (SH9 surface mount)	20 20Q 35 65			03 grey 06 white 09 black 30 ultra blue 40 dusty blue 42 aqua blue	D136 ▲
				1 Z C S	50 metal dark blue 53 metal light grey 57 metal dark grey 58 metal bordeaux	<input type="checkbox"/> <input type="checkbox"/> <input type="checkbox"/>
						038 RESET 105 ENTER 118 OK 119 SET
						120 MENU 121 FUNC 122 HOME 123 ⏻

\*\* White legends on black caps are standard, other options are available but considered custom products. See pages 34-35 or www.apem.com

Ordering example: 4x 5GTH93561+1ZB16DLMH13609 + 1x 5GTH93561+1ZCS16LMH12309 (with illumination) OR 4x 5GSH920+1ZB09 + 1x 5GSH920+1ZCS09 (without illumination) OR \*5GTH92002Q (Illuminated quiet version)

Please see colour codes, updates of products and changes of specifications on www.apem.com



- Module should be attached to the front plate with bolts (bolts not supplied by MEC)
- Round solution
- Ø34.25 mm
- h = 11.7 mm; 12.2 mm
- Temp. Range:
  - Solid cap: -40/+65°C
  - Transparent cap: -40/+85°C
- Recommended panel cut-out: Ø35,0 - 35,5 Depending on application

All dimensions in mm

Tolerances +/-0.2mm

## DIMENSIONS

### Navimec Module

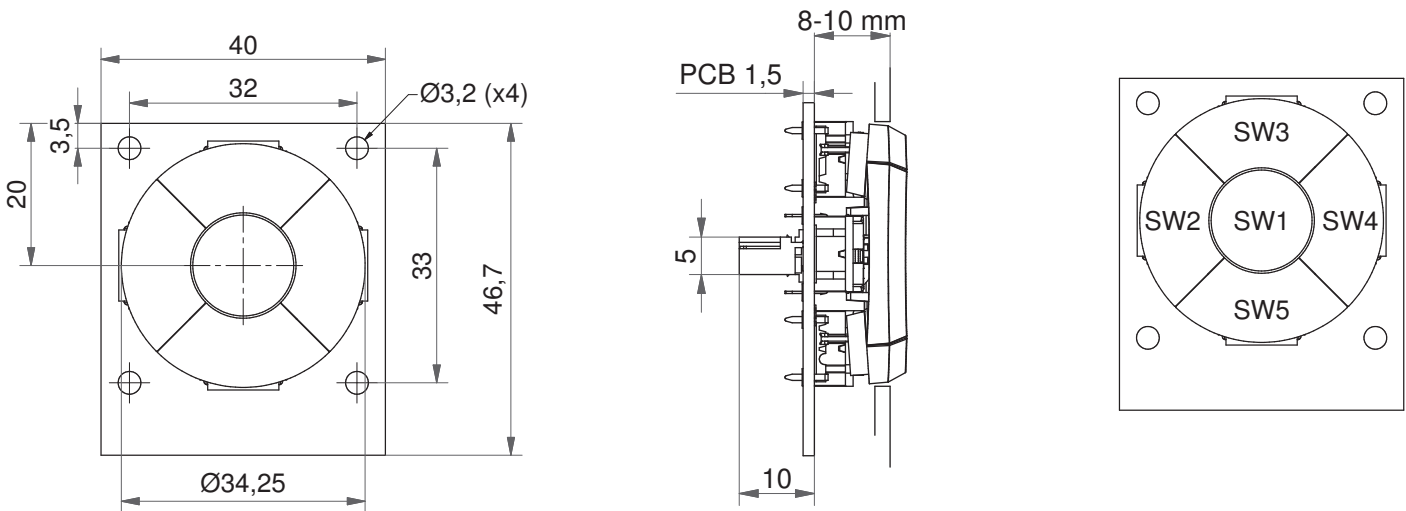

When the 1ZB is activated the diameter changes from 34,25 mm to 35,0 mm

## HOW TO ORDER

navimec<sup>™</sup> Module ordering options:

- navimec<sup>™</sup> Module excl. keycaps
- navimec<sup>™</sup> Module incl. keycaps
- navimec<sup>™</sup> Module incl. keycaps with legends
- Illuminated navimec<sup>™</sup> Module excl. keycaps
- Illuminated navimec<sup>™</sup> Module incl. keycaps with legends

Part no. for a module:

navimec<sup>™</sup> Module has many customisation options regarding actuation force, cap and LED colours and legends. Because of that "How to order" has been placed on page 43.

See previous page for information on switch and cap options.

SEE THE "HOW TO ORDER" GRAPH AS WELL AS CIRCUIT DIAGRAM AND CONNECTOR INFO ON [PAGE 43](#)

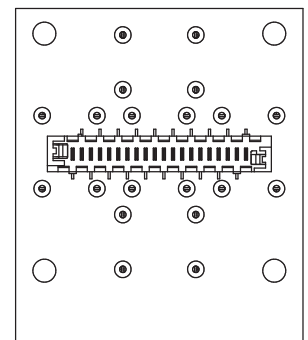
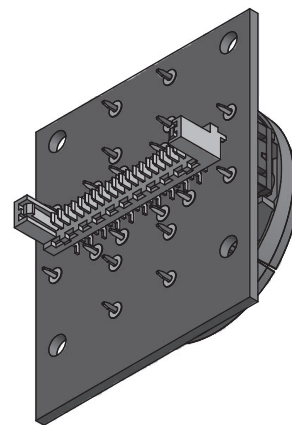

Ordering example:

95NA200913611806 (without illumination)

95NB350116LMH13612309 (with illumination)

Please see colour codes, updates of products and changes of specifications on [www.apem.com](http://www.apem.com)

- Round cap
- Panel sealed solution, designed to control a unit or navigate a display
- Ø29.5 mm
- h = 12.3 mm
- Material: ABS/polycarbonate
- Temp. Range:
  - Solid cap: -40/+65°C
  - Transparent cap: -40/+85°C
- Panel cut-out: 1ZW-Ø30.3

All dimensions in mm

Tolerances +/-0.2mm



### DIMENSIONS

TH + 1ZW

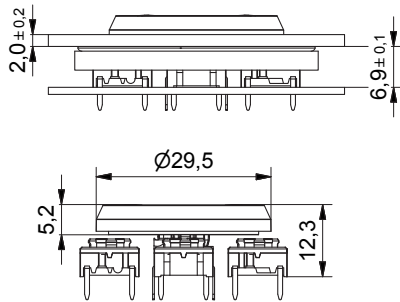

PCB layout

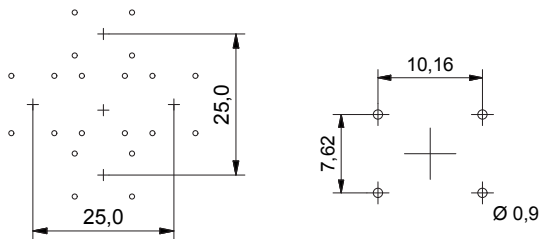

We recommend using through-hole terminals for precise placing.

### MOUNTING EXAMPLE

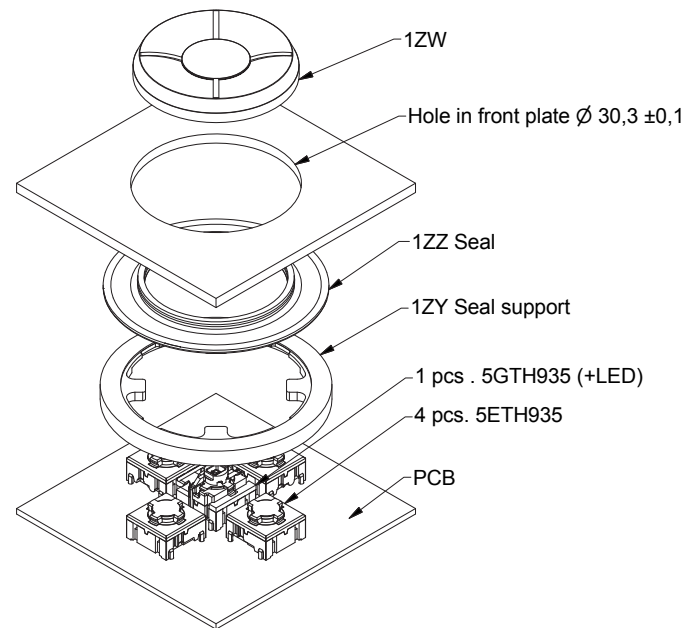

### ILLUMINATED – HOW TO ORDER

Switch	Mounting	Actuation force	LED (optional)		Cap	Colour code	Legend code
5 G	<input type="checkbox"/> <input type="checkbox"/> <input type="checkbox"/>	<input type="checkbox"/> <input type="checkbox"/>	<input type="checkbox"/> <input type="checkbox"/> <input type="checkbox"/> <input type="checkbox"/>	+	<input type="checkbox"/> <input type="checkbox"/> <input type="checkbox"/>	<input type="checkbox"/> <input type="checkbox"/>	<input type="checkbox"/> <input type="checkbox"/>
	TH9 through-hole (SH9 surface mount)	35 65	02 blue 22 green 42 yellow 61 white 82 red 2242 green/yellow 8222 red/green 8242 red/yellow		1ZW 	00 blue 03 grey 06 white 08 red 09 black 16 frosted white	136 ▲ 118 OK 123 ⏻

Switch	Mounting	Actuation force		Panel seal	Seal	Seal support
5 E	<input type="checkbox"/> <input type="checkbox"/> <input type="checkbox"/>	<input type="checkbox"/> <input type="checkbox"/>	+	<input type="checkbox"/> <input type="checkbox"/> <input type="checkbox"/> <input type="checkbox"/>	<input type="checkbox"/> <input type="checkbox"/> <input type="checkbox"/> <input type="checkbox"/>	<input type="checkbox"/> <input type="checkbox"/>
	TH9 through-hole (SH9 surface mount)	35 65			09 black 	1ZY 

Ordering example:

5GTH935+1ZW09+4x 5ETH935+1ZZ09+1ZY without illumination OR 5GTH96582+1ZW16LMH13611809+4x 5ETH965+1ZZ09+1ZY with illumination

Please see colour codes, updates of products and changes of specifications on [www.apem.com](http://www.apem.com)



- Round cap
- Designed to control a unit or navigate in a display
- Ø29.5 mm
- h =12.0 mm
- Material: ABS/polycarbonate
- Temp. Range:
  - Solid cap: -40/+65°C
  - Transparent cap: -40/+85°C
- Panel cut-out: 1Z-Ø30.3

All dimensions in mm

Tolerances +/-0.2mm

## DIMENSIONS

TH + 1Z

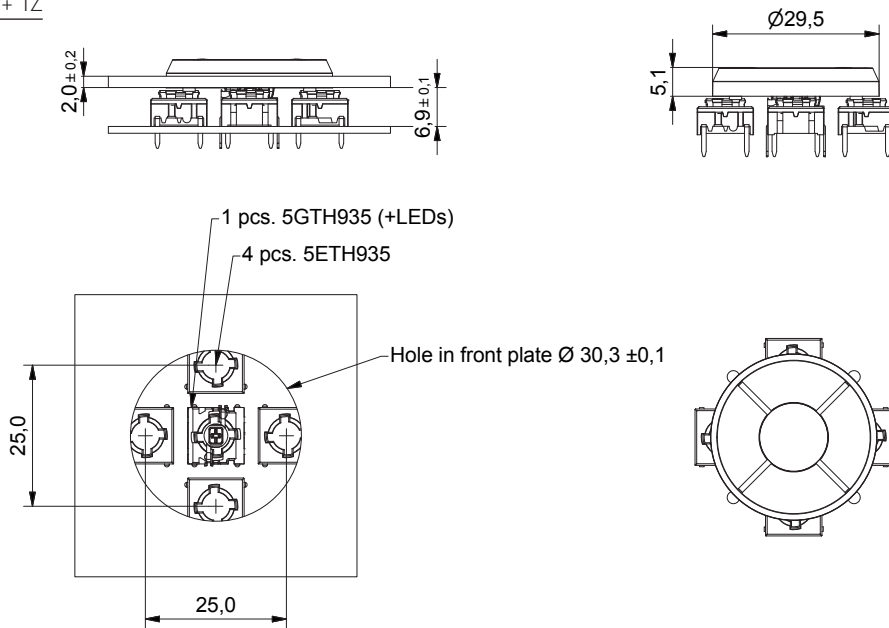

PCB layout

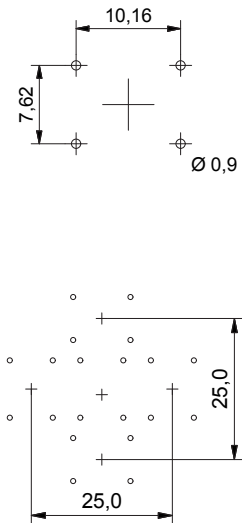

We recommend using through-hole terminals for precise placing

## ILLUMINATED – HOW TO ORDER

Switch	Mounting	Actuation force	LED (optional)	+	Cap	Colour code	Legend code
5 G	<input type="checkbox"/> <input type="checkbox"/> <input type="checkbox"/>	<input type="checkbox"/> <input type="checkbox"/>	<input type="checkbox"/> <input type="checkbox"/> <input type="checkbox"/> <input type="checkbox"/>	+	<input type="checkbox"/> <input type="checkbox"/> <input type="checkbox"/>	<input type="checkbox"/> <input type="checkbox"/>	<input type="checkbox"/> <input type="checkbox"/> <input type="checkbox"/>
	TH9 through-hole (SH9 surface mount)	35 65	02 blue 22 green 42 yellow 61 white 82 red 2242 green/yellow 8222 red/green 8242 red/yellow		1Z 	00 blue 03 grey 06 white 08 red 09 black 16 frosted white	136 ▲ 118 OK 123 ⏻

Switch	Mounting	Actuation force
5 E	<input type="checkbox"/> <input type="checkbox"/> <input type="checkbox"/>	<input type="checkbox"/> <input type="checkbox"/>
	TH9 through-hole (SH9 surface mount)	35 65

Ordering example:  
5GTH935+1Z03 +4x 5ETH935 without illumination OR 5GTH96561+1Z16LMH13611809 +4x 5ETH965 with illumination  
Please see colour codes, updates of products and changes of specifications on [www.apem.com](http://www.apem.com)

- Module should be attached to the front plate with bolts (bolts not supplied by MEC)
- Round cap
- Panel sealed or non-panel sealed solution
- Ø29.5 mm
- h =12.3 mm; 12.0 mm
- Temp. Range:
  - Solid cap: -40/+65°C
  - Transparent cap: -40/+85°C
- Panel cut-out: 1ZW/1Z module-Ø30.3

All dimensions in mm

Tolerances -/+0.2mm

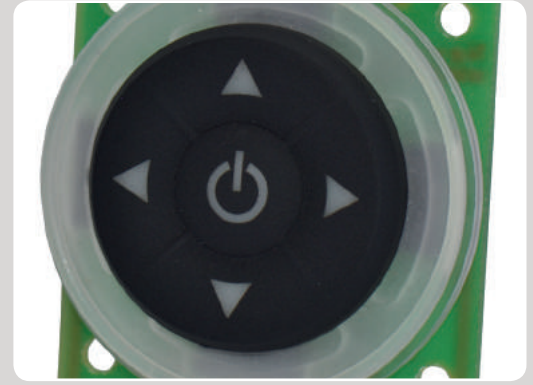

### DIMENSIONS

#### 1Z module

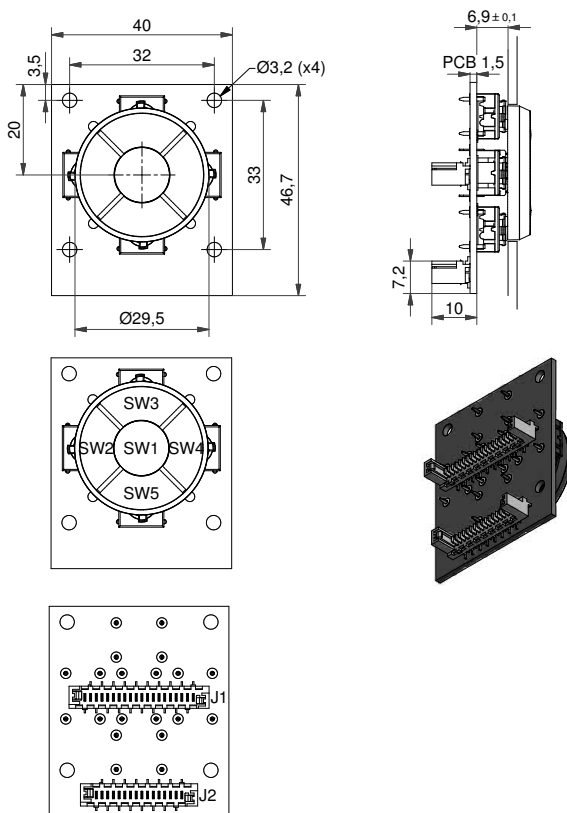

#### 1ZW module

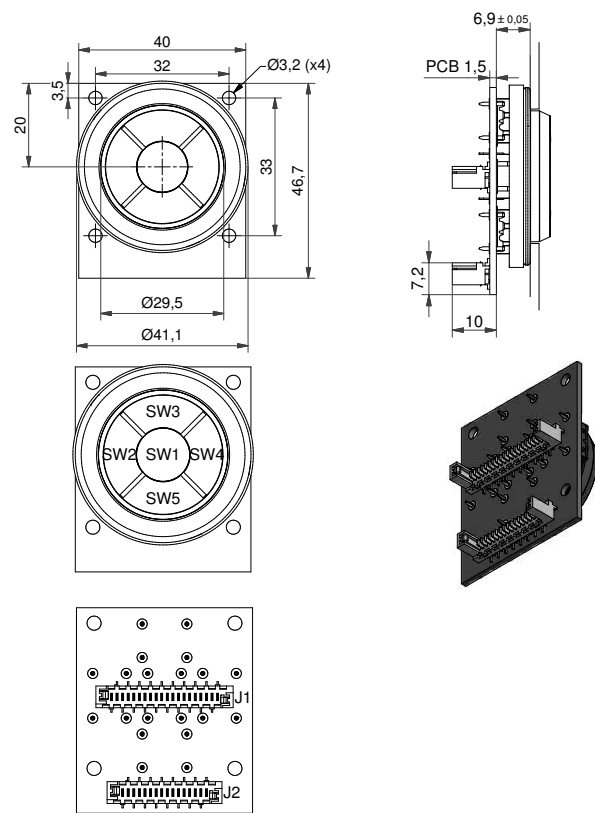

### HOW TO ORDER

controlmec<sup>™</sup> Module ordering options:

- controlmec<sup>™</sup> Module excl. keycaps
- controlmec<sup>™</sup> Module incl. keycaps
- controlmec<sup>™</sup> Module incl. keycaps with legends
- illuminated controlmec<sup>™</sup> Module excl. keycaps
- illuminated controlmec<sup>™</sup> Module incl. keycaps with legends
- Sealed controlmec<sup>™</sup> Module excl. keycaps
- Sealed controlmec<sup>™</sup> Module incl. keycaps
- Sealed controlmec<sup>™</sup> Module incl. keycaps with legends
- Sealed illuminated controlmec<sup>™</sup> Module excl. keycaps
- Sealed illuminated controlmec<sup>™</sup> Module incl. keycaps with legends

Part no. for a module:

controlmec<sup>™</sup> Module has many customisation options regarding actuation force, cap and LED colours and legends. Because of that "How to order" has been placed on page 43.

See previous pages for information on switch and cap options.

SEE THE "HOW TO ORDER" GRAPH AS WELL AS CIRCUIT DIAGRAM AND CONNECTOR INFO ON [PAGE 43](#)

Ordering example: 95CA350913611806 (without illumination)  
 95CB358216LMH13612309 (with illumination)  
 95CC6509 (sealed without illumination)  
 95CD356116LMH13612309 (sealed with illumination)

Please see colour codes, updates of products and changes of specifications on [www.apem.com](http://www.apem.com)



- Panel sealing option
- Round cap; Ø30 mm
- h =11 mm
- Material: ABS/polycarbonate
- Temp. Range:
  - Solid cap: -40/+65°C
  - Transparent cap: -40/+85°C
- Panel cut-out: 10R/10RF/10RM-Ø30.6
- Height of the spacer: 3.9mm
- Sealing IP67 (we recommend 6.5N switch)

All dimensions in mm

Tolerances +/-0.2mm

### DIMENSIONS

#### TH + 10R

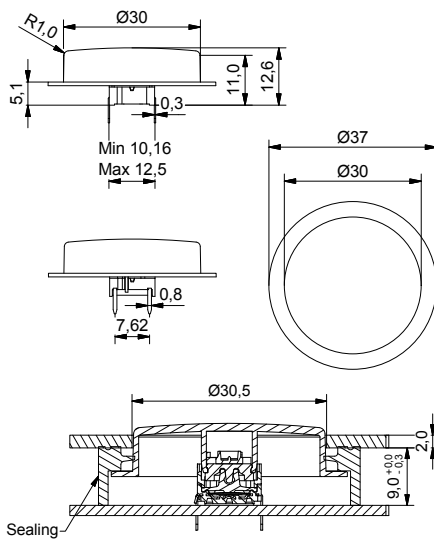

#### TH + 10RF

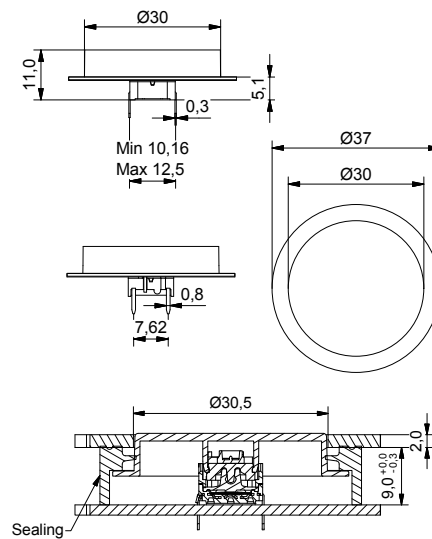

#### SMD w/LED + 10RM

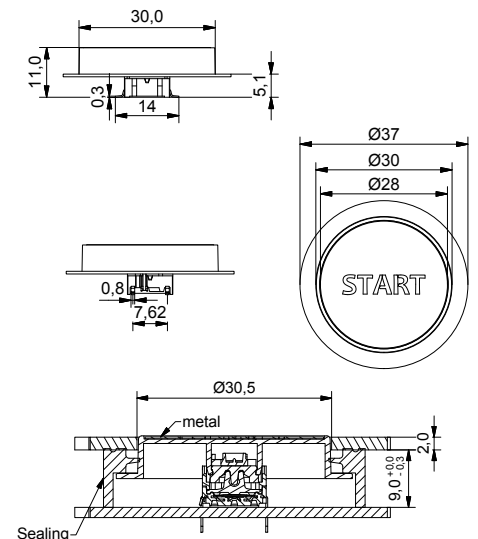

### ILLUMINATED - HOW TO ORDER

Switch	Mounting	Actuation force	LED	Cap	Colour code	Sealing	Spacer
5 G							
	TH9 through-hole	20	02 blue	10R	16 frosted white	optional	optional
	SH9 surface mount	35	22 green	10RF			
		65	42 yellow	10RM			
		Q*	61 white				
			82 red				
			2242 green/yellow				
			8222 red/green				
			8242 red/yellow				

\*For an illuminated quiet 2.0N switch add Q to the end of the switch part number.

See pages 34-35 for metal legend.

### NON-ILLUMINATED- HOW TO ORDER

Switch	Mounting	Actuation force	Cap	Colour code	Sealing	Spacer
5 G						
	TH9 through-hole	20	10R	00 blue	optional	optional
	SH9 surface mount	20Q	10RF	02 green		
		35		03 grey		
		65		04 yellow		
				06 white		
				08 red		
				09 black		

Ordering example: 5GSH965+10R08+10RY non-illuminated with spacer OR 5GTH93502+10RM16031 with illumination OR 5GSH965+10RF0901806+10RW with sealing OR \*5GTH92061Q (illuminated quiet version)

Please see colour codes, updates of products and changes of specifications on [www.apem.com](http://www.apem.com)

- Panel sealing option
- Square cap; 22 mm x 22 mm
- h = 11 mm
- Material: ABS/polycarbonate
- Temp. Range:
  - Solid cap: -40/+65°C
  - Transparent cap: -40/+85°C
- Panel cut-out: 10Q/10QM-22.5 x 22.5
- Height of the spacer: 3.9mm/5.1mm
- Sealing IP65 (we recommend 6.5N switch)



All dimensions in mm

Tolerances +/0.2mm

### DIMENSIONS

#### TH + 10Q

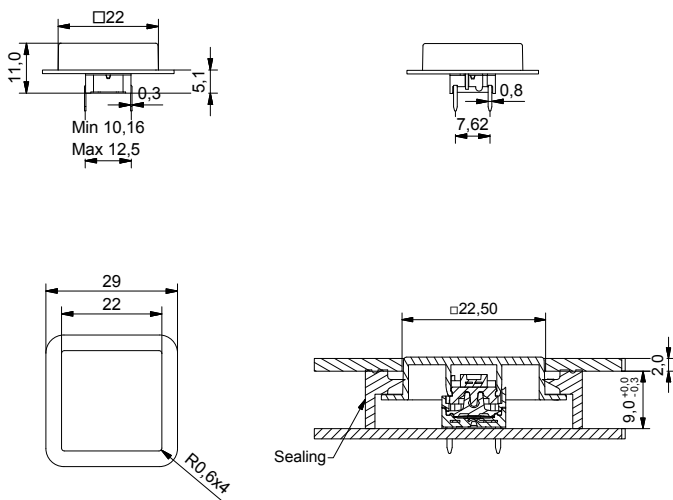

#### SMD w/LED + 10QM

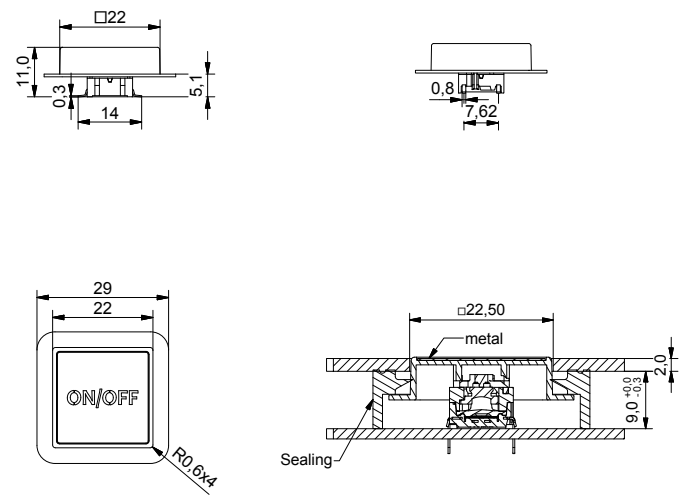

### ILLUMINATED – HOW TO ORDER

Switch	Mounting	Actuation force	LED		Cap	Colour code	Sealing	Spacer
5 G	<input type="checkbox"/> <input type="checkbox"/> <input type="checkbox"/>	<input type="checkbox"/> <input type="checkbox"/>	<input type="checkbox"/> <input type="checkbox"/> <input type="checkbox"/> <input type="checkbox"/>	+	<input type="checkbox"/> <input type="checkbox"/> <input type="checkbox"/> <input type="checkbox"/>	<input type="checkbox"/> <input type="checkbox"/>	+ <input type="checkbox"/> <input type="checkbox"/> <input type="checkbox"/> <input type="checkbox"/> W	+ <input type="checkbox"/> <input type="checkbox"/> <input type="checkbox"/> <input type="checkbox"/> Y
	TH9 through-hole SH9 surface mount	20 35 65 Q*	02 blue 22 green 42 yellow 61 white 82 red 2242 green/yellow 8222 red/green 8242 red/yellow		10Q 10QM	16 frosted white	optional	optional

\*For an illuminated quiet 2.0N switch add Q to the end of the switch part number.

See pages 34-35 for metal legend.

### NON-ILLUMINATED – HOW TO ORDER

Switch	Mounting	Actuation force		Cap	Colour code	Sealing	Spacer
5 G	<input type="checkbox"/> <input type="checkbox"/> <input type="checkbox"/>	<input type="checkbox"/> <input type="checkbox"/> <input type="checkbox"/>	+	<input type="checkbox"/> <input type="checkbox"/> <input type="checkbox"/> <input type="checkbox"/>	<input type="checkbox"/> <input type="checkbox"/>	+ <input type="checkbox"/> <input type="checkbox"/> <input type="checkbox"/> <input type="checkbox"/> W	+ <input type="checkbox"/> <input type="checkbox"/> <input type="checkbox"/> <input type="checkbox"/> Y
	TH9 through-hole SH9 surface mount	20 20Q 35 65		10Q	00 blue 02 green 03 grey 04 yellow 06 white 08 red 09 black	optional	optional

Ordering example: 5GSH920+10Q00+10QY non-illuminated with spacer OR 5GTH93582+10QM16017 with illumination OR 5GSH965+10Q0910506+10QW with sealing OR \*5GTH92001Q (illuminated quiet version)  
Please see colour codes, updates of products and changes of specifications on [www.apem.com](http://www.apem.com)

## AUDIO – FOOT PEDAL



MEC part no: 5GTH935 + 1VS09

## SECURITY PANEL



MEC part no: 5GSH920 + 1PS chromed

## COFFEE MACHINE



MEC part no: 5GTH965 + 1TS09 +1TS00

## LEISURE - CASINO CHIP SORTER



MEC part no: navimec™, 5GTH935 + 1ZCS09

## MEDICAL – REMOTE CONTROL FOR CT SCANNER



MEC part no: navimec™, 5GSH935 + 1ZCS30 + 1GAS04

## AUDIO – TURNTABLE



MEC part no: navimec™, 5GSH935 + 1KS1116

## AGRICULTURE – TRACTOR

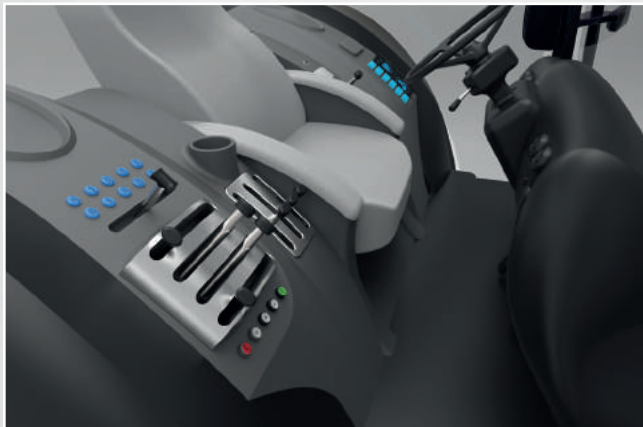

MEC part no: 5GTH965 + 1JS00



MEC part no: 5GTH965 + 1KS0016

## MILITARY - NAVIGATION CHART SYSTEMS



MEC part no: 5GSH935 + 1TS09 + 1PS09

## AUDIO – CHILDREN'S RADIO

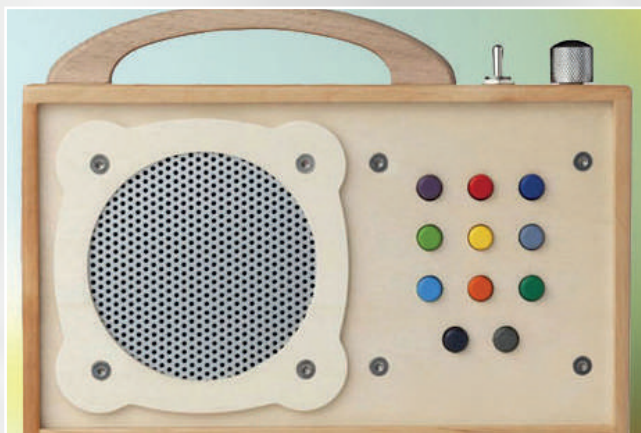

MEC part no: 5GSH935 + 1DS in many colours

## INSTRUMENTATION – MEASUREMENT CONTROLLER

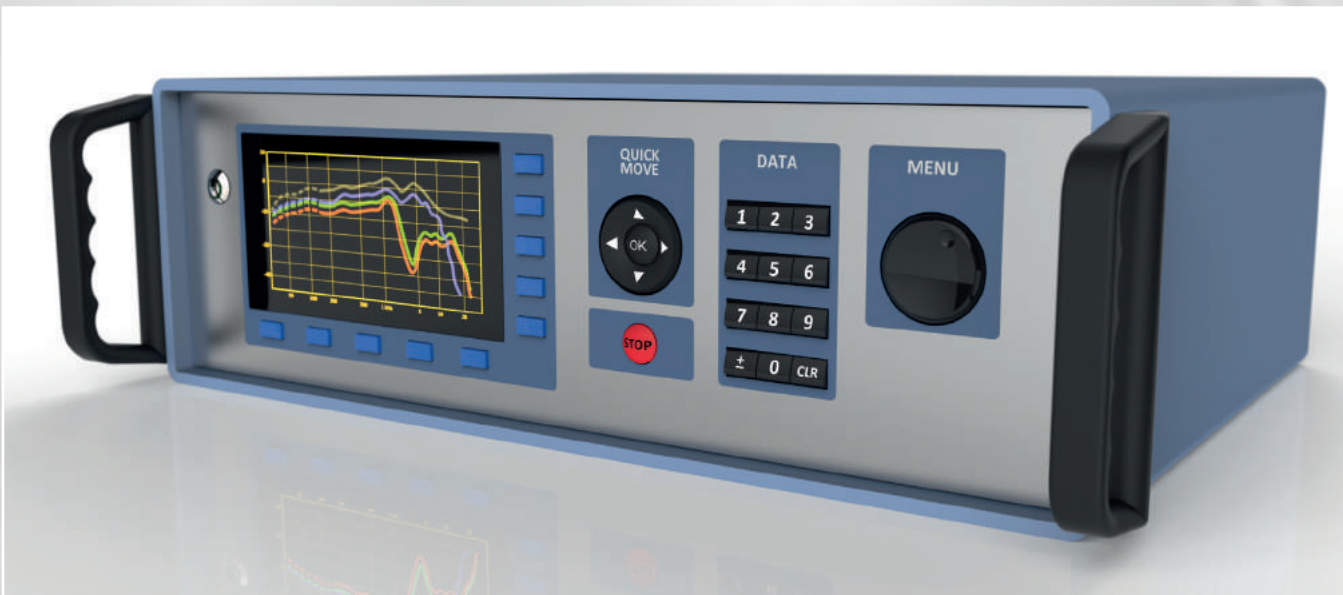

MEC part no: navimec™, 5GSH920 + 1ZCS08 + 1A09 + 1PS30

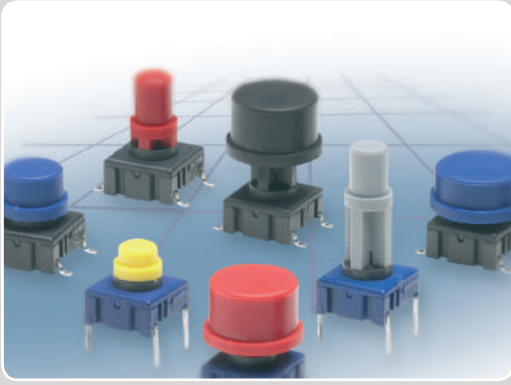

- Round caps
- 2400 options in the series
- Ø5.2 mm; Ø7.8 mm; Ø11.6 mm
- h =10.4-22.5 mm
- Material: polyamide
- Temp. Range:-40/+160°C

All dimensions in mm

Tolerances +/-0.2mm

## DIMENSIONS

### SMD+Round ø5.2

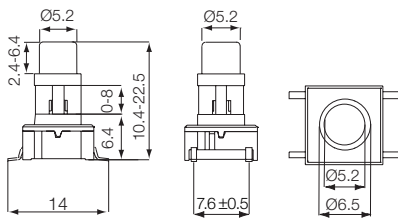

### TH+Round ø7.8

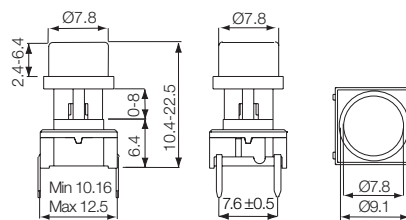

### SMD+Round ø11.6

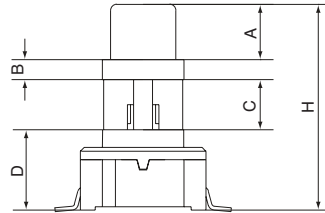
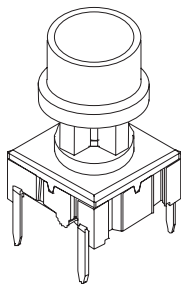
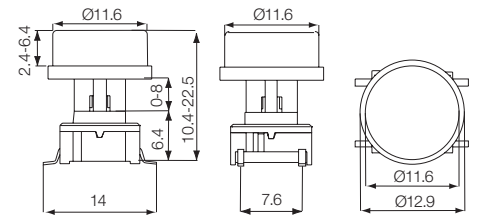

### The Concept

H= Overall heights from 10.4-22.5  
 A= Variable height from 2.4 to 6.4  
 H has to exceed A with min. 8.0  
 B= Fixed recess 1.6  
 D= Fixed switch 6.4  
 C= variable from 0-8.1  
 C=H-A-B-D  
 All measurements in mm

## HOW TO ORDER

Switch	Shape and size	Colour code	Overall height H	Height above recess A	Tape*
<b>3 E S H</b>	<input type="checkbox"/>	<input type="checkbox"/>	<input type="checkbox"/>	<input type="checkbox"/>	<input type="checkbox"/>
<b>3 E T H</b>	<b>A</b> 5.2 Round	<b>60</b> blue	<b>A</b> 10.4	<b>A</b> 2.4	<b>R</b>
	<b>E</b> 7.8 Round	<b>63</b> grey	<b>B</b> 11.0	<b>B</b> 3.0	
	<b>K</b> 11.6 Round	<b>64</b> yellow	<b>C</b> 12.0	<b>C</b> 3.5	
		<b>68</b> red	<b>D</b> 12.5	<b>D</b> 4.0	
		<b>69</b> black	<b>E</b> 13.0	<b>E</b> 4.5	
			<b>F</b> 14.0	<b>F</b> 5.0	
			<b>G</b> 15.0	<b>G</b> 5.6	
			<b>H</b> 16.0	<b>H</b> 6.4	
			<b>J</b> 19.0		
			<b>K</b> 22.5		

Ordering example:

Examples switch and cap: 3ETHE64CC = Switch 3ETH, 7.8 round cap, yellow, overall height 12.0, height above recess 3.5, (height under recess 0.5).

Example caap alone: 3E-E63FF = Cap, 7.8 round, grey, overall height with switch 14.0, height above recess 5.0, (height under recess 1.0).

Min. order is 2.000 pcs. per shape, size and heights for parts mentioned above.

For heights not mentioned in the list a start-up fee will apply.

\*Only overall height up to 12.5mm can be supplied on tape.

Please see colour codes, updates of products and changes of specifications on [www.apem.com](http://www.apem.com)

- Square caps
- 2400 options in the series
- 5.2 mm x 5.2 mm; 7.8 mm x 7.8 mm; 11.6 mm x 11.6 mm
- h = 10.4-22.5 mm
- Material: polyamide
- Temp. Range: -40/+160°C

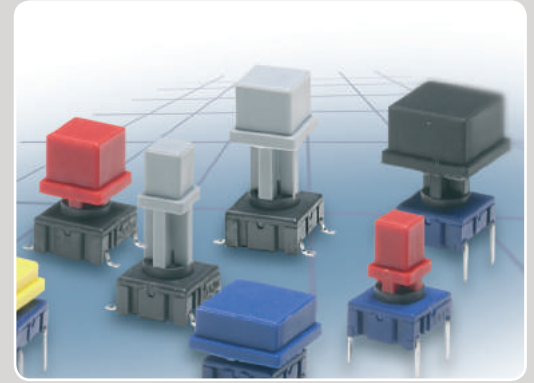

All dimensions in mm

Tolerances +/-0.2mm

## DIMENSIONS

### TH+Square 5.2

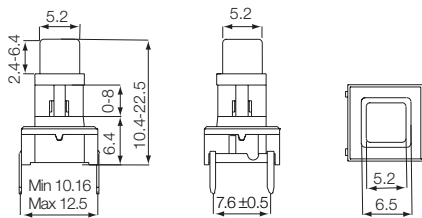

### SMD+Square 7.8

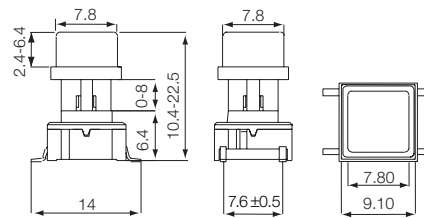

### TH+Square 11.6

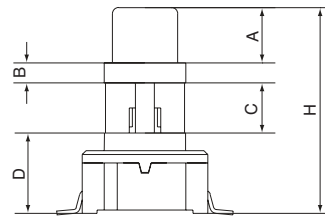
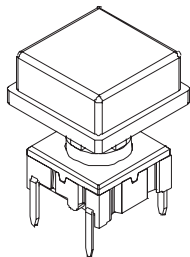
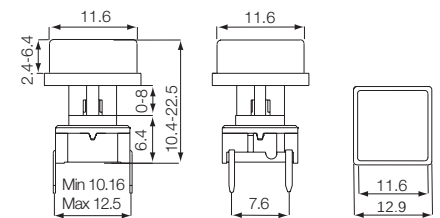

### The Concept

H= Overall heights from 10.4-22.5  
 A= Variable height from 2.4 to 6.4  
 H has to exceed A with min. 8.0  
 B= Fixed recess 1.6  
 D= Fixed switch 6.4  
 C= variable from 0-8.1  
 C=H-A-B-D  
 All measurements in mm

## HOW TO ORDER

Switch	Shape and size	Colour code	Overall height H	Height above recess A	Tape*
<b>3 E S H</b>	<input type="checkbox"/>	<input type="checkbox"/>	<input type="checkbox"/>	<input type="checkbox"/>	<input type="checkbox"/>
<b>3 E T H</b>	<b>B</b> 5.2 Square	<b>60</b> blue	<b>A</b> 10.4	<b>A</b> 2.4	<b>R</b>
	<b>F</b> 7.8 Square	<b>63</b> grey	<b>B</b> 11.0	<b>B</b> 3.0	
	<b>L</b> 11.6 Square	<b>64</b> yellow	<b>C</b> 12.0	<b>C</b> 3.5	
		<b>68</b> red	<b>D</b> 12.5	<b>D</b> 4.0	
		<b>69</b> black	<b>E</b> 13.0	<b>E</b> 4.5	
			<b>F</b> 14.0	<b>F</b> 5.0	
			<b>G</b> 15.0	<b>G</b> 5.6	
			<b>H</b> 16.0	<b>H</b> 6.4	
			<b>J</b> 19.0		
			<b>K</b> 22.5		

Ordering example:

Examples switch and cap: 3ESH60AA = Switch 3ESH, 5.2 square cap, blue, overall height 10.4, height above recess 2.4, (height under recess 0).

Example caap alone: 3E-E63FF = Cap, 7.8 square, grey, overall height with switch 14.0, height above recess 5.0, (height under recess 1.0).

Min. order is 2.000 pcs. per shape, size and heights for parts mentioned above.

For heights not mentioned in the list a start-up fee will apply.

\*Only overall height up to 12.5mm can be supplied on tape.

Please see colour codes, updates of products and changes of specifications on [www.apem.com](http://www.apem.com)



- Round cap
- Solution panel sealed to IP 67
- Ø10.6 mm
- h =24.2-27.2 mm (h from front panel=14.3 mm)
- Material: ABS/polycarbonate
- Temp. Range:
  - Solid cap: -40/+65°C
  - Transparent cap: -40/+85°C

All dimensions in mm

Tolerances +/-0.2mm

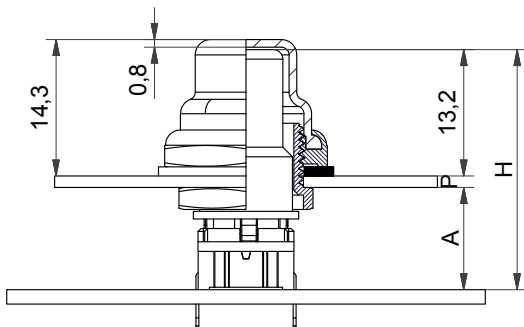

$$H=A+P+13.2$$

this leaves nominal 0.3 mm clearance between the top of the cap and the inner side of the sealing boot to accomplish assembly tolerances. A can be chosen between 10-13 mm, we recommend 10 mm to reduce building height and optimise cap guidance.

A	P	CAP	H	BUSHING
10.0	1.0	AQCSxx-24.2	24.2	AQN-0.5
10.0	2.0	AQCSxx-25.2	25.2	AQN-0.5
10.0	3.0	AQCSxx-26.2	26.2	AQN-2.5
10.0	4.0	AQCSxx-27.2	27.2	AQN-2.5



Cap is available in black (09) or transparent (11).

The dimension H is the overall height of the switch+cap.

Bushing AQN-0.5 accepts panel thickness (P) 0.5-2.5 mm.

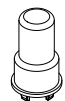

Bushing AQN-2.5 accepts panel thickness (P) 2.5-4.0 mm.

### ILLUMINATED – HOW TO ORDER

Switch	Mounting	Actuation force	LED	Bushing	Cap	Overall height (H)	Sealing boot
5 G				+ A Q N - .	+ A Q C S	- . .	+ A Q B 0 1
<b>TH9</b>	<b>20</b>	<b>02</b> blue	<b>0.5</b>	<b>11</b> transparent	<b>24.2</b>	incl. sealing	
through-hole	<b>35</b>	<b>22</b> green	<b>2.5</b>			<b>25.2</b>	<b>11</b> transparent
	<b>65</b>	<b>42</b> yellow			<b>26.2</b>		
<b>SH9</b>	<b>Q*</b>	<b>61</b> white			<b>27.2</b>		
surface mount		<b>82</b> red					
		<b>2242</b> green/yellow					
		<b>8222</b> red/green					
		<b>8242</b> red/yellow					

\*For an illuminated quiet 2.0N switch add Q to the end of the switch part number.

### NON-ILLUMINATED – HOW TO ORDER

Switch	Mounting	Actuation force	Bushing	Cap	Overall height (H)	Sealing boot
5 G			+ A Q N - .	+ A Q C S	- . .	+ A Q B 0 1
<b>TH9</b>	<b>20</b>	<b>0.5</b>	<b>09</b> black	<b>24.2</b>	incl. sealing	
through-hole	<b>20Q</b>	<b>2.5</b>		<b>25.2</b>	<b>09</b> black	
	<b>35</b>			<b>26.2</b>		
<b>SH9</b>	<b>65</b>			<b>27.2</b>		
surface mount						

Ordering example: 5GTH93522+AQN-0.5+AQCS11-24.2+aqb0111 with illumination OR 5GSH965+AQN-2.5+AQCS09-27.2+aqb0109 non-illuminated, \*5GSH92082Q (illuminated quiet version)

Please see colour codes, updates of products and changes of specifications on [www.apem.com](http://www.apem.com)

- Designed for 5G cap retention system
- Stackable, giving the possibility to match most overall heights
- $h = 5-10$  mm
- Material: Nylon
- Temp. Range:
  - Switch:  $-40/+160^{\circ}\text{C}$
  - LED:  $-30/+85^{\circ}\text{C}$
  - Solid keycap:  $-40/+65^{\circ}\text{C}$
  - Transparent keycap:  $-40/+85^{\circ}\text{C}$

All dimensions in mm

Tolerances  $\pm 0.2\text{mm}$



## DIMENSIONS

### 2SS

5 mm, 6 mm, 7 mm, 8 mm, 9 mm, 10 mm

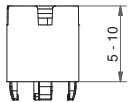

### SMD + 2SS+1GCS

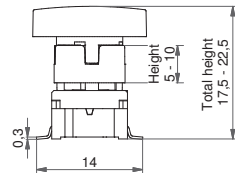

### SMD + 2SS+1DS

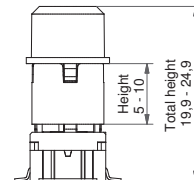

### TH + 2SS+1TS

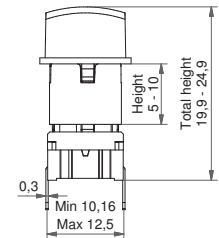

## HOW TO ORDER

Switch	Mounting	Actuation force	LED (optional)	+	Cap	Extender 2SS height
<b>5 G</b>	<input type="checkbox"/> <input type="checkbox"/> <input type="checkbox"/>	<input type="checkbox"/> <input type="checkbox"/>	<input type="checkbox"/> <input type="checkbox"/> <input type="checkbox"/> <input type="checkbox"/>	<b>+</b>	<input type="checkbox"/> <input type="checkbox"/> <input type="checkbox"/>	<b>2 5 5 0 9 - . 0</b>
	<b>TH9</b> through-hole <b>SH9</b> surface mount	<b>20</b> <b>35</b> <b>65</b> <b>Q*</b>	<b>02</b> blue <b>22</b> green <b>42</b> yellow <b>61</b> white <b>82</b> red <b>2242</b> green/yellow <b>8222</b> red/green <b>8242</b> red/yellow		See the table below	<b>05.0</b> <b>06.0</b> <b>07.0</b> <b>08.0</b> <b>09.0</b> <b>10.0</b>

\*For an illuminated quiet 2.0N switch add Q to the end of the switch part number.

### How to use 1GAS/1GCS + 2SS under foil

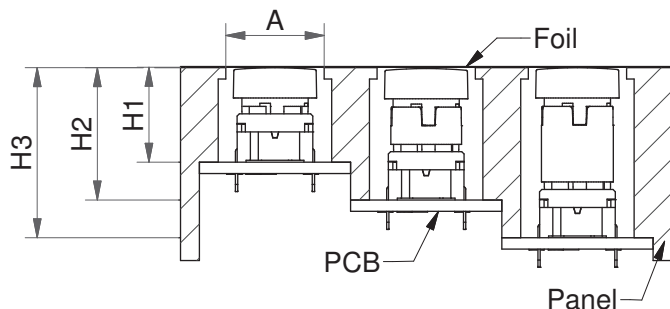

A=We recommend you to allocate enough space for travel of the foil and leave the area free from adhesive  
H=We recommend you to calculate this dimension from the top of the PCB to the inner top of the panel with a small pretention 0.1-0.2mm

### 2SS can be used with all 5G-type snap-on caps

All 2SS extenders are stackable giving the possibility to match most overall heights.

Cap	Original height (H1)	Height with a single extender (H2;H3)
1DS/1ES/1FS	14.9	19.9-24.9
1GAS/1GCS	12.5	17.5-22.5
1KS/1KBS/1KCS	19.1; 20.2; 20.1	24.1; 25.2; 25.1-29.1; 30.2; 30.1
1NS	14.9	19.9-24.9
1TS/1US/1VS	14.9	19.9-24.9
1WAS/1WDS/1WPS	15.7	20.7-25.7
1XS	18.5	23.5-28.5
1ZCS	11.7	16.7-21.7

Ordering example: 5GTH935+1GAS09+2SS09-06.0 OR \*5GSH920Q or 5GTH92082Q (quiet version)  
Please see colour codes, updates of products and changes of specifications on [www.apem.com](http://www.apem.com)

# Legends

Available for Multimec caps

standard legends

LEGEND	1B09U_ 1B09D_	1DS09_	1FS096R_	1ZB09D_ 1ZB16DLMH_	1ZCS_	10R_ & 10RF_ 10RM16_	10Q_ 10QM16_
0	000	000	000				
1	001	001	001				
2	002	002	002				
3	003	003	003				
4	004	004	004				
5	005	005	005				
6	006	006	006				
7	007	007	007				
8	008	008	008				
9	009	009	009				
#		107	107				
*		019	019				
→		033					
←		133					
↑		034					
↓		134					
↙		135	135				
+						054	054
-						059	059
▲				136*			
⏻		123	123		123*	123	123
ON/OFF						017	017
STOP						018	018
START						031	031
RESET					038	038	038
CANCEL						048	048
ENTER					105	105	105
ESC					051		
OK					118*	118	118
SET					119		
MENU					120		
FUNC					121		
HOME					122		

## STANDARD OPTIONS

1B  
pad printed

1DS  
pad printed

1FS  
reverse printed

1ZB  
pad printed  
\*laser marked

1ZCS  
pad printed  
\*reverse printed  
\*laser marked

10R(F) & 10Q  
pad printed  
reverse printed

10RM & 10QM  
metal symbol

# Legends

Available for Multimec caps

how to order

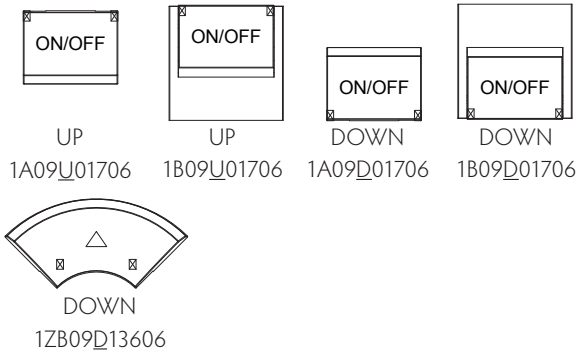

## POSITIONING OF LEGENDS ON ROCKER-ACTION CAPS

When ordering legends for caps with hinge-type cap retention system, it is important to note the position of the cap. An extra letter (U or D) needs to be added to the part number to refer to the position of the hinges in relation to the legend. See samples to the left.

Rocker-action caps without a lens: 1A, 1B, 1M, 1ZA and 1ZB

Orientation of the switch:

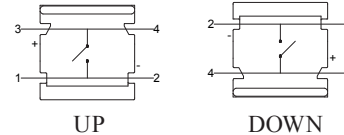

## LEGEND ILLUMINATION

Option 1: LASER MARKED

In case of laser marked legends an "LM" is added after the cap colour, before the legend code. We recommend using hard paint (additional "H" ) for increased lifetime of the paint. E.g. 1ZB16DLMH13609

Option 2: REVERSE PRINTED

In case of reverse printed caps an "R" is added after the cap colour, before the legend code. Especially relevant when standard legends has both negative and positive print option. E.g. 1FS096R00009

Option 3: METAL SYMBOL

Only available for 10RM and 10QM (therefore the "M"). E.g. 10RM16059

## STANDARD AND CUSTOM LEGENDS - HOW TO ORDER

### STANDARD LEGENDS

- Standard are only certain legends on certain caps. See the table on the previous page.
- All standard pad-printed legends are white on black caps.
- All standard reverse-printed and laser marked legends are black on frosted white cap.

Cap	Cap colour	Direction*	Type*	Legend	Legend colour*
□□□□	□□	□□	□□□□	□□□□	□□
<b>1B</b>	<b>00</b> blue	<b>D</b> down	<b>LM</b> laser marked on soft paint	<b>001</b> 1	<b>00</b> blue
<b>1DS</b>	<b>02</b> green	<b>U</b> up	<b>LMH</b> laser marked on hard paint	<b>002</b> 2	<b>02</b> green
... etc	<b>03</b> grey		<b>R</b> reverse printed	<b>003</b> 3	<b>03</b> grey
	<b>04</b> yellow	*only for hinge-type caps	*in case of illumination	... etc	<b>04</b> yellow
	<b>06</b> white				<b>06</b> white
	<b>08</b> red				<b>08</b> red
	<b>09</b> black				<b>09</b> black
	<b>16</b> frosted white				... etc
	... etc				

\*in case of laser marked legends the colour of the soft or hard paint

## NOTE:

- The size of the legends listed may not correspond to the actual size.
- If you decide to use one of the standard legends without any adjustments (without a new cliché) on another cap than designated in the table, then there is no start-up cost, for this to apply the cap has to be black and the print white.
- Standard legend colours are white paint on a black cap and black paint on a frosted white cap. Other colour combinations are handled as custom.
- For further information on legends please contact your local distributor or MEC.



























PLEASE FIND THE FULL LIST OF AVAILABLE LEGENDS ON MEC WEBSITE [www.apem.com](http://www.apem.com)

Ordering example: 1ZW0913611806; 1B06U13508; 10R16R10509

Please see colour codes, updates of products and changes of specifications on [www.apem.com](http://www.apem.com)

# Switch series

## Selection guide

	MOMENTARY	LATCHING	QUIET	KEY FEATURES
2.5N actuation force	<b>1540x</b> >10M operations -40/+160°C silver or gold contacts 	<b>1545x</b> 5M operations -40/+160°C silver or gold contacts 	<b>15420</b> >10M operations -40/+160°C gold contacts 	<b>unimec:</b> through-hole double pole 8 contact functions 1.8mm travel
	<b>STANDARD</b>	<b>STANDARD</b>	<b>ILLUMINATED</b>	<b>KEY FEATURES</b>
3.5N (3 series) actuation force	<b>3CTH9</b> through-hole -40/+160°C 	<b>3ETH9</b> through-hole -40/+160°C 	<b>3FTH9xxRAS</b> through-hole 	<b>Multimec 3 series:</b> momentary/ single pole >10 million operations IP 67 1 mm travel
	<b>3CSH9</b> surface mount -40/+160°C 	<b>3ESH9</b> surface mount -40/+160°C 		
2.0N actuation force	<b>5ETH920</b> through-hole quiet version RAS version 	<b>5GTH920</b> through-hole quiet version RAS version 	<b>5GTH920xx</b> through-hole quiet version 	<b>Multimec 5 series:</b> momentary/ single pole >10 million operations IP 67 – 1mm travel Temp. range: -40/+160°C
	<b>5ESH920</b> surface mount quiet version 	<b>5GSH920</b> surface mount quiet version 	<b>5GSH920xx</b> surface mount quiet version 	<b>Function:</b> normally open (NO) or normally closed/normally open (NC/NO)
3.5N actuation force	<b>5ETH935</b> through-hole RAS version NO or NC/NO 	<b>5GTH935</b> through-hole RAS version NO or NC/NO 	<b>5GTH935xx</b> through-hole 	<b>LED colours:</b> 01 blue - 22 green - 42 yellow 61 white - 82 red - 8222 red/ green - 2242 green/yellow 8242 red/yellow
	<b>5ESH935</b> surface mount NO or NC/NO 	<b>5GSH935</b> surface mount NO or NC/NO 	<b>5GSH935xx</b> surface mount 	<b>RAS:</b> right angle version only available with through-hole (TH) normally open (NO) switch
6.5N actuation force	<b>5ETH965</b> through-hole RAS version 	<b>5GTH965</b> through-hole RAS version 	<b>5GTH965xx</b> through-hole 	
	<b>5ESH965</b> surface mount 	<b>5GSH965</b> surface mount 	<b>5GSH965xx</b> surface mount 	

10 MILLION ACTUATIONS

IP 67 SEALING

NORMALLY OPEN (NO) OR

NORMALLY CLOSED/NORMALLY OPEN (NC/NO)

THROUGH-HOLE RIGHT ANGLE VERSION

QUIET CONTACT OPTION WITH 2.0N

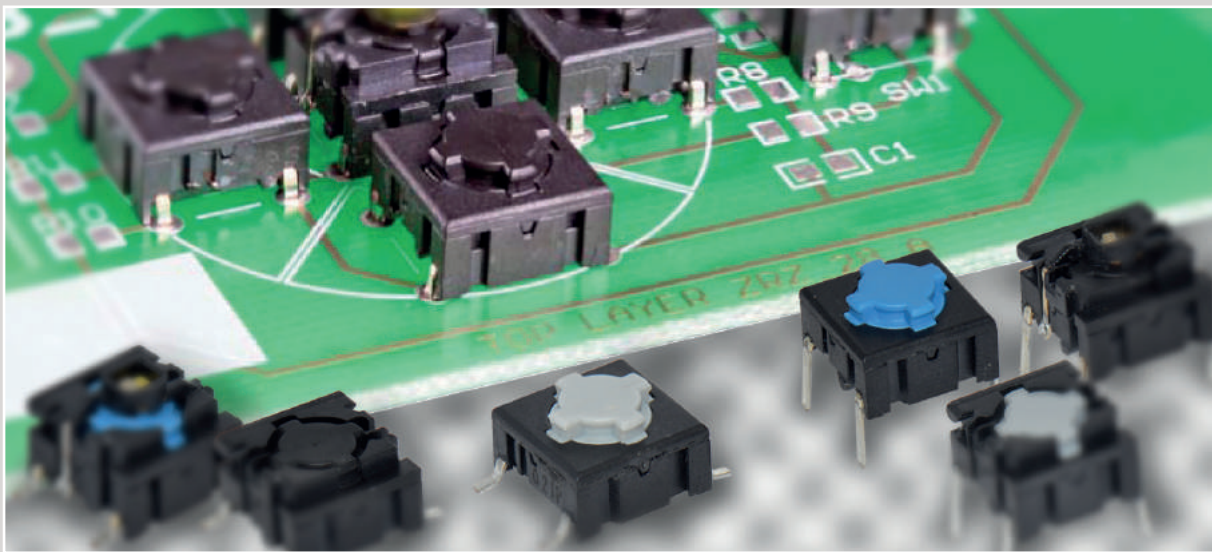

multimec® 5 series is the new generation of 3A, 3F, 4A and 4F switch. In principle the multimec® 5 series is very similar to the 3 series - it has the same pin layout, the same dimensions and the same electrical specifications.

The four main updates are the cap retention system and actuator, three standard actuation forces, one temperature range and possibility of normally closed/normally open function.



5E

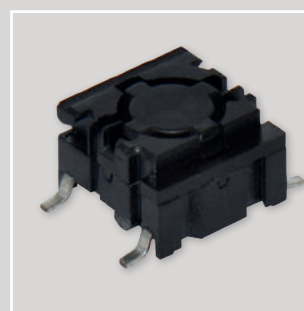

5G



- Through-hole (TH) or surface mount (SMD)
- 50mA/24VDC
- Single pole/momentary
- 10,000,000 operations lifetime (NO function)
- Temperature range:
  - Switch: -40/+160°C
  - LED: -40/+85°C
- IP 67 sealing
- Actuation force: 2.0N, 3.5N, 6.5N
- NO or NC/NO

All dimensions in mm

Tolerances +/-0.2mm

### THROUGH-HOLE (TH)

5G

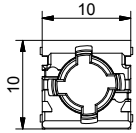
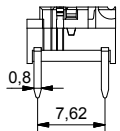
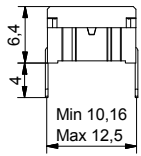

5G illuminated

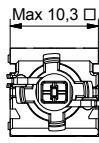
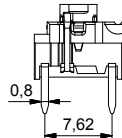
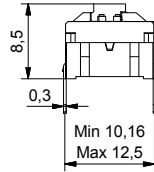

5E

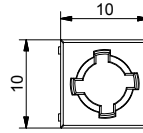
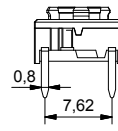
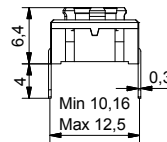

### PCB LAYOUT

Non-illuminated

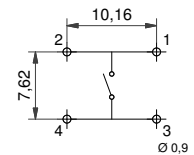

1 LED

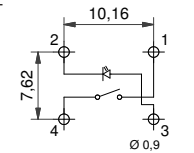

2 LED

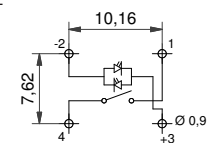

### SURFACE MOUNT (SMD)

5G

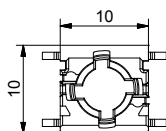
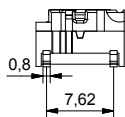
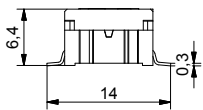

5G illuminated

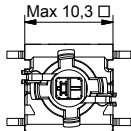
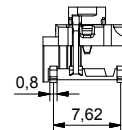
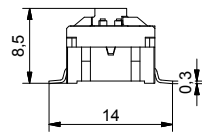

5E

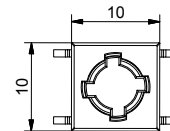
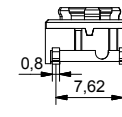
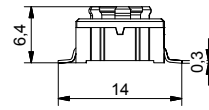

### PCB LAYOUT

Non-illuminated

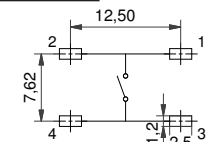

1 LED

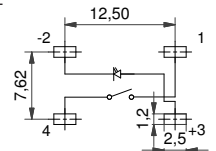

2 LED

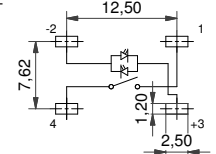

### NORMALLY CLOSED/NORMALLY OPEN FUNCTION

### NOT FOR SALE IN JAPAN

### CIRCUIT DIAGRAM

- Available for 5E and non-illuminated 5G in 3.5N actuation force.
- Same PCB layout as the NO 5E and 5G
- Housing colour is **grey**

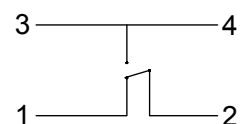

### RIGHT ANGLE SWITCHES

### PCB LAYOUT

5E

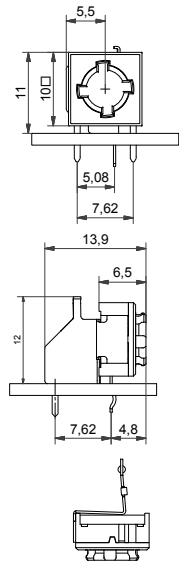

5G

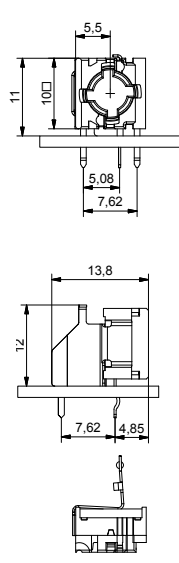

5G + 1SS

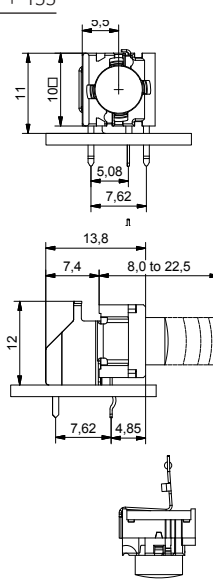

5G + 1DS

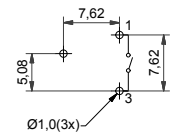
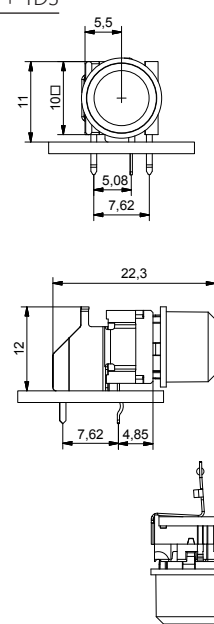

multimec® 5 series has only normally open (NO) non-illuminated right angle switch.

### ILLUMINATED – HOW TO ORDER

Switch	Mounting	Actuation force	LED	Quiet (optional)
<b>5 G</b>	<input type="checkbox"/> <input type="checkbox"/> <input type="checkbox"/>	<input type="checkbox"/> <input type="checkbox"/> <input type="checkbox"/>	<input type="checkbox"/> <input type="checkbox"/> <input type="checkbox"/>	<input type="checkbox"/>
	<b>TH9</b> through-hole <b>SH9</b> surface mount	<b>20</b> <b>35</b> <b>65</b>	<b>02</b> blue <b>22</b> green <b>42</b> yellow <b>61</b> white <b>82</b> red <b>2242</b> green/yellow <b>8222</b> red/green <b>8242</b> red/yellow	<b>Q</b> only for 2.0N

### NON-ILLUMINATED – HOW TO ORDER

Switch	Mounting	Actuation force	RAS (optional)	or	NC/NO (only for 3.5N)
<b>5 E</b>	<input type="checkbox"/> <input type="checkbox"/> <input type="checkbox"/>	<input type="checkbox"/> <input type="checkbox"/> <input type="checkbox"/>	<input type="checkbox"/> <input type="checkbox"/> <input type="checkbox"/>	<input type="checkbox"/> <input type="checkbox"/> <input type="checkbox"/>	<input type="checkbox"/> <input type="checkbox"/> <input type="checkbox"/> <input type="checkbox"/>
	<b>TH9</b> through-hole <b>SH9</b> surface mount	<b>20</b> <b>20Q</b> <b>35</b> <b>65</b>	<b>RAS</b> right angle switch		<b>NCNO</b> normally closed/ normally open function

Switch	Mounting	Actuation force	RAS (optional)	or	NC/NO (only for 3.5N)
<b>5 G</b>	<input type="checkbox"/> <input type="checkbox"/> <input type="checkbox"/>	<input type="checkbox"/> <input type="checkbox"/> <input type="checkbox"/>	<input type="checkbox"/> <input type="checkbox"/> <input type="checkbox"/>	<input type="checkbox"/> <input type="checkbox"/> <input type="checkbox"/>	<input type="checkbox"/> <input type="checkbox"/> <input type="checkbox"/> <input type="checkbox"/>
	<b>TH9</b> through-hole <b>SH9</b> surface mount	<b>20</b> <b>20Q</b> <b>35</b> <b>65</b>	<b>RAS</b> right angle switch		<b>NCNO</b> normally closed/ normally open function

Ordering example: 5ESH935 (non-illuminated), 5GTH9658222 (illuminated), 5GSH935NCNO (normally closed/normally open); 5ETH920RAS (right angle) 5ETH920Q or 5GSH92061Q (quiet versions)

Please see colour codes, updates of products and changes of specifications on [www.apem.com](http://www.apem.com)



- Through-hole (TH) or surface mount (SMD)
- 50mA/24VDC
- Single pole/momentary
- 10,000,000 operations lifetime
- Temperature range:
  - High temp: -40/+160C
- IP 67 sealing
- Actuation force: 3.5N
- Most caps in the catalogue have a version for mounting on 3F switch as well. Contact MEC for further information.

All dimensions in mm

Tolerances +/-0.2mm

### 3C (TH, SMD & RAS)

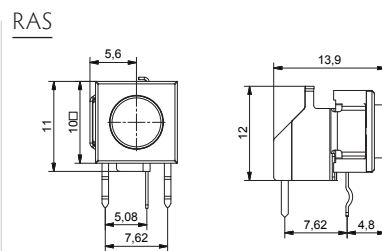
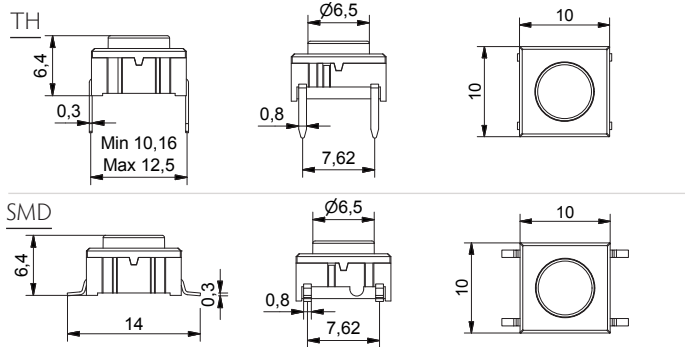

### PCB LAYOUT

#### Through-hole

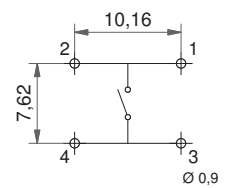

#### Surface mount

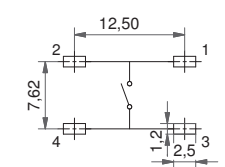

### 3E (TH, SMD & RAS)

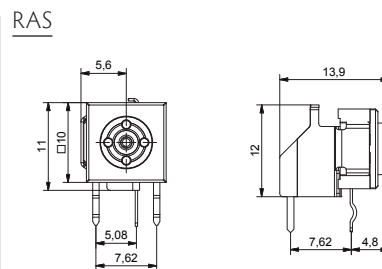
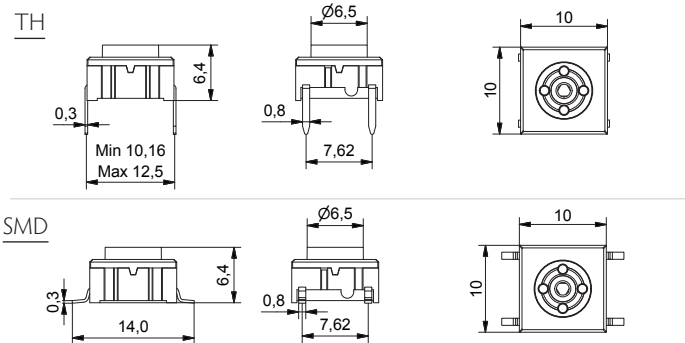

#### Through-hole RAS

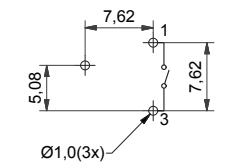

### 3F (TH, SMD & RAS w/LED)

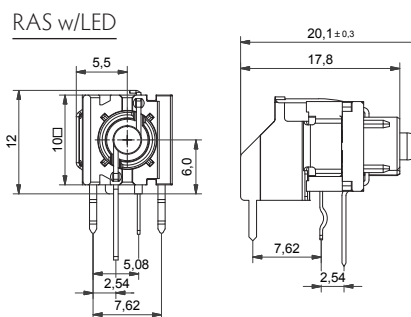
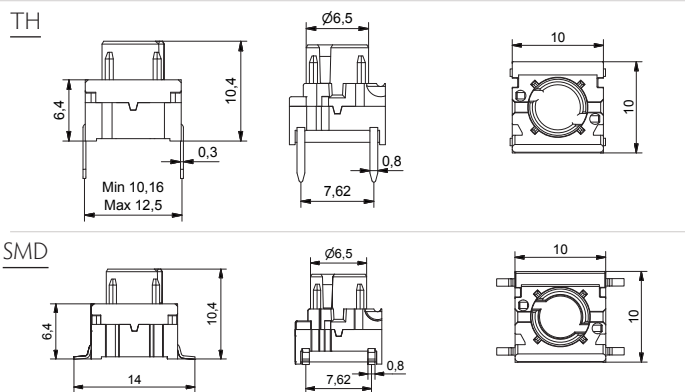

#### Through-hole illuminated RAS

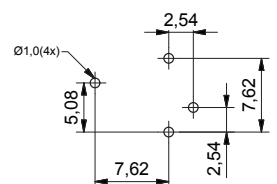

### HOW TO ORDER

Switch	Mounting	Temperature range	LED (onyl for 3F)	Right angle support
<input type="checkbox"/>	<input type="checkbox"/>	<b>H 9</b>	<input type="checkbox"/>	<input type="checkbox"/>
<b>3C</b>	<b>T</b> through-hole	<b>H9</b> high temp.	<b>00</b> blue <b>60</b> white <b>8020</b> red/ green	<b>RAS</b> optional
<b>3E</b>	<b>S</b> surface mount		<b>20</b> green <b>80</b> red	3FTH9RAS with LED can be used with the 3 series keycaps: 1D, 1E, 1F, 1K, 1N, 1Q, 1R, 1S, 1T, 1U, 1V, 1WA, 1WD, 1WP, 1X. Ask further information on caps from MEC.
<b>3F</b>			<b>40</b> yellow <b>2040</b> green/ yellow <b>8040</b> red/ yellow	

Ordering example: 3CTH9, 3ESH9, 3FTH9RAS Please see colour codes, updates of products and changes of specifications on [www.apem.com](http://www.apem.com)

## Tape & Reel

Tape and reel is available for the parts listed and has the following specifications:

Reel diameter:	Ø330mm	Tape and reel material:	antistatic or better
Tape width:	24mm	Quantity per reel:	see list
Pitch:	see list		

### 3C/3E/5E/5G multimec® tape & reel

Part No.	Ordering Code	Pitch	Quantity per reel
3CSH9	3CSH9R	16	500
3ESH9	3ESH9R	16	500
5ESH9XX	5ESH9XXR	16	500
5GSH9XX	5GSH9XXR	16	500
5XSH9XX1SSXX-08.0	5XSH9XXR1SSXX-08.0	20	250
5XSH9XX1SSXX-09.5	5XSH9XXR1SSXX-09.5	20	250
5XSH9XX1SSXX-10.4	5XSH9XXR1SSXX-10.4	20	250
5XSH9XX1SSXX-11.0	5XSH9XXR1SSXX-11.0	20	250
5XSH9XX1SSXX-12.0	5XSH9XXR1SSXX-12.0	20	250
All varimec h <12.5; add R after part no.			20 250

### illuminated 5G multimec® tape & reel

Part No.	Ordering Code	Pitch	Quantity per reel
5GSH9XX02	5GSH9XX02R	20	250
5GSH9XX22	5GSH9XX22R	20	250
5GSH9XX42	5GSH9XX42R	20	250
5GSH9XX61	5GSH9XX61R	20	250
5GSH9XX82	5GSH9XX82R	20	250
5GSH9XX2242	5GSH9XX2242R	20	250
5GSH9XX8222	5GSH9XX8222R	20	250
5GSH9XX8242	5GSH9XX8242R	20	250

## How to assemble

multimec®  
5GS+1A/H

multimec®  
5GS+1B/C+2C/D

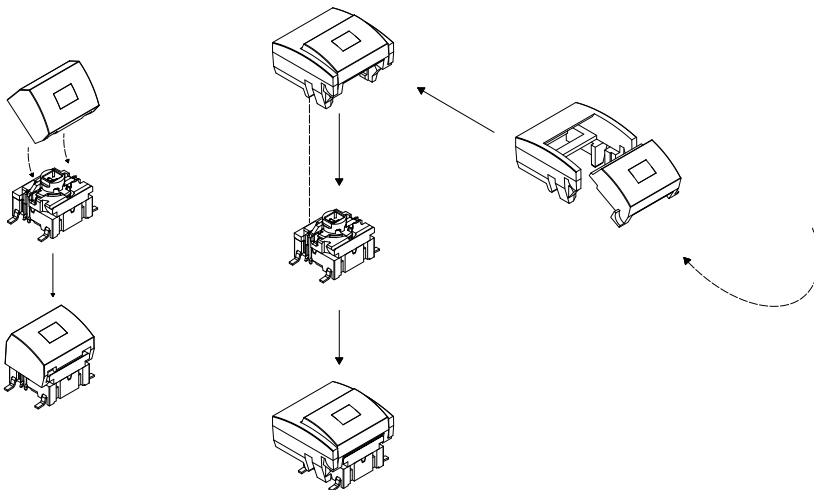

## Operating force

(typical example)

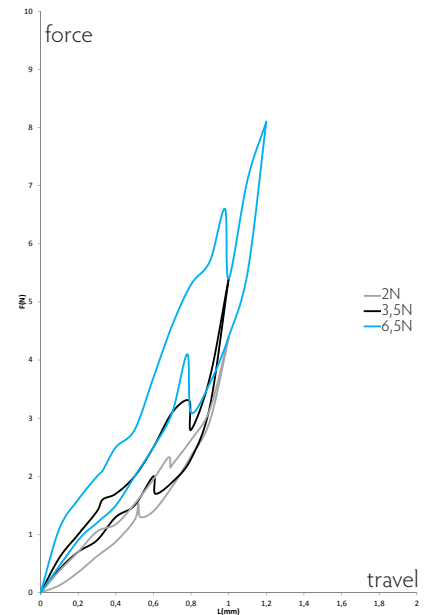

## Mounting tool for multimec® through-hole switches

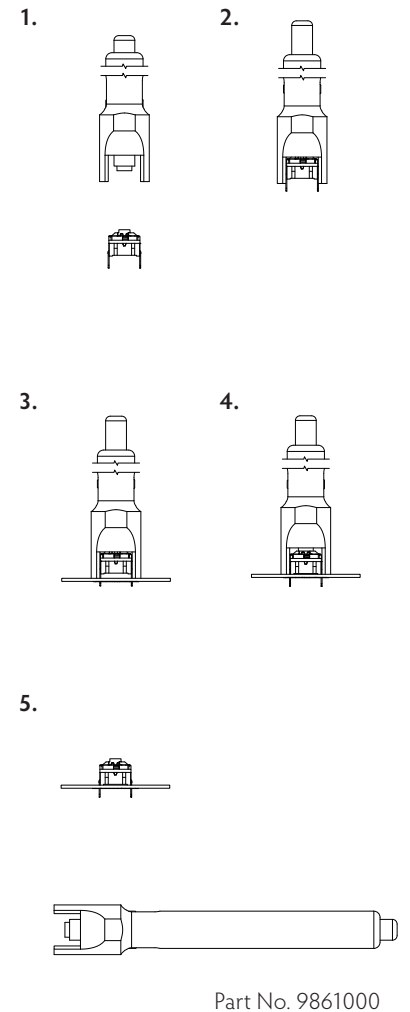

## Basic switch spacing

through-hole (TH)

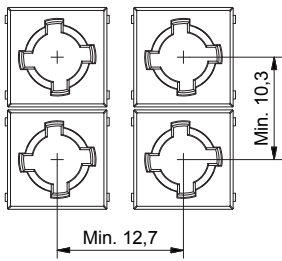

surface mount (SMD)

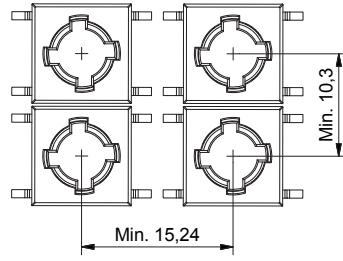

## Recommended switch/cap spacing

Switch spacing

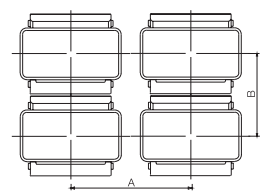

Cap dimensions

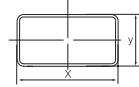

Panel cut-out

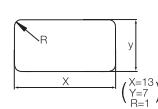

## Panel cut-out

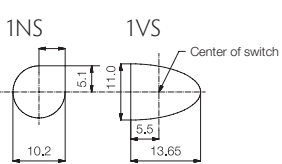

## Spacing examples

multimec  
5GT+1B/C+2C/D

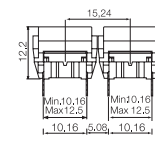

multimec  
5GS+1B/C+2C/D

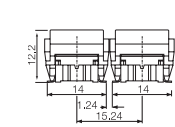

multimec  
5GT + 1A/H

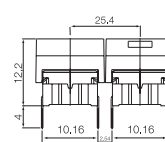

multimec  
5GT + 1M

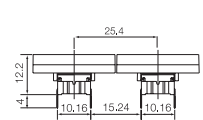

multimec  
1NS + 1NS + 1NS

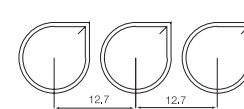

multimec  
1VS + 1TS+ 1VS

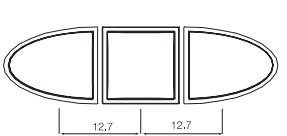

Cap series	Recommended min. switch spacing AxB	Nominal cap dimension WxH	Recommended min. panel cut-out
1A/1H	12.7x10.16	12.6x10.1	13.0x10.5
1B/1C+2C/2D	15.24x15.24	15.1x15.1	15.5x15.5
1DS/1ES/1FS	12.7x12.7	ø9.6	ø10.0
1GAS	12.7x11.14	ø11	ø11.4
1GCS	15.14x15.14	ø15	ø15.4
1JS	12.7x12.7	ø9.6	ø10.4
1KS/1KBS/1KCS	15.24x15.24	14.3x14.3	14.7x14.7
1M	25.4x10.16	25.0x10.	25.7x10.5
1NS	12.7x12.7	ø9.8/□4.9	ø10.2/□5.1
1PS/1QS/1RS	15.24x10.16	6.5x12.5	7.0x13.0, R max. 1.0
1SS/1IS/1LS	12.7x12.7	ø6.5	ø7.0
1TS	12.7x12.7	10.6x10.6	11.0x11.0
1US	12.7x12.7	ø10.6	ø11.0
1VS	12.7x12.7	10.6x13.25	11.0x13.65
1WAS/1WPS	12.7x10.3	12.5x6.5	12.9x6.9
1WDS	15.34x10.3	15.2x8.0	15.6x8.4
1XS	12.7x12.7	9.4x7.4	9.8x7.9
1YS	17x17	15x15	16x16
1ZA	18.84x10.3	18.7x10.1	19.4x10.5
1ZB	24.34x12.1	R1=7.4; R2=17.5 90°	R1=7.1; R2=17.5-17.75 90°
1ZCS	14.44x14.44	ø14.3	ø14.7
1Z/1ZW	35.5x35.5; 41.6x41.6	ø29.5	ø30.3
10R/10RF/10RM	40.5x40.5	ø30.0	ø30.6
10Q/10QM	32.5x32.5	22x22	22.5x22.5

Circuit diagram for switches

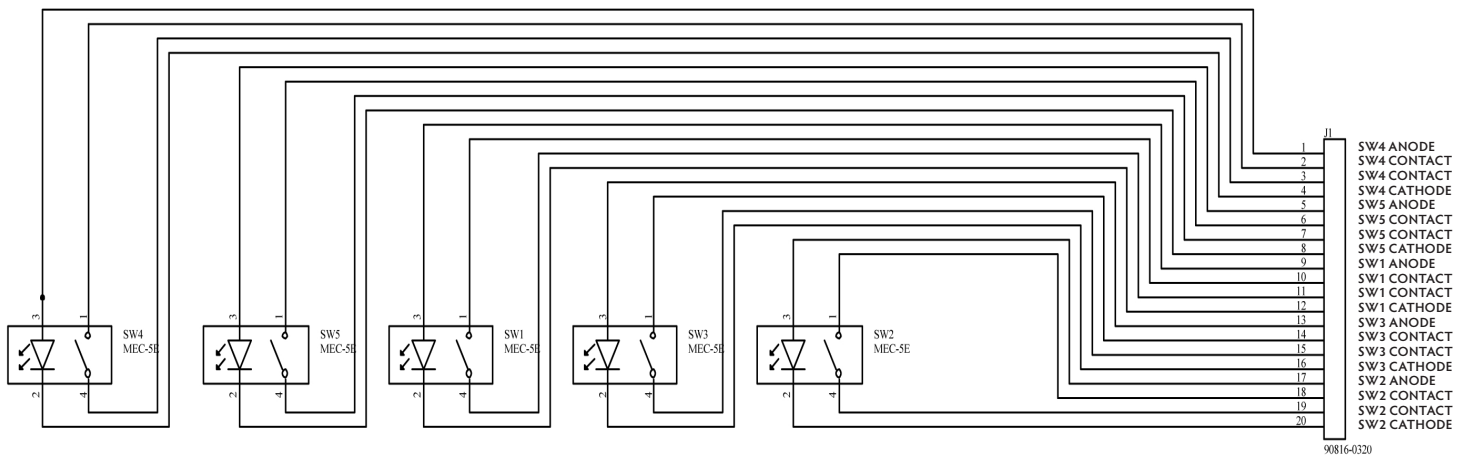

Circuit diagram for additional LEDs for controlmec™

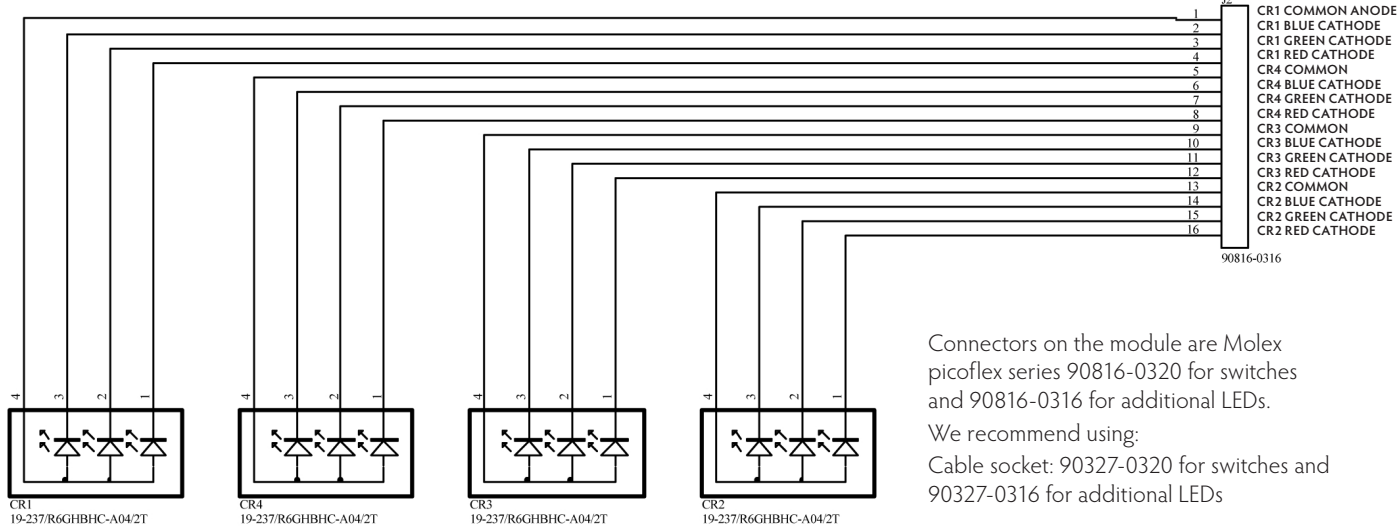

Connectors on the module are Molex picoflex series 90816-0320 for switches and 90816-0316 for additional LEDs. We recommend using: Cable socket: 90327-0320 for switches and 90327-0316 for additional LEDs

**HOW TO ORDER - MODULES**

Module	Cap	Type	Actuation force	LED*
<input type="checkbox"/> 9 <input type="checkbox"/> 5	<input type="checkbox"/>	<input type="checkbox"/>	<input type="checkbox"/>	<input type="checkbox"/>
<b>C</b> controlmec module	<b>A</b> non-illuminated	<b>20</b> 2.0N**	<b>02</b> blue	<b>2242</b> green/yellow
<b>N</b> navimec module	<b>B</b> illuminated	<b>35</b> 3.5N	<b>22</b> green	<b>8222</b> red/green
<b>Q</b> 10Q module	<u>Sealed controlmec module:</u>	<b>65</b> 6.5N	<b>42</b> yellow	<b>8242</b> red/yellow
<b>R</b> 10R module	<b>C</b> non-illuminated		<b>61</b> white	
	<b>D</b> illuminated		<b>82</b> red	

Cap colour	Legend type*	Legend on the edges*	Legend in the centre*	Legend colour*
<input type="checkbox"/>	<input type="checkbox"/>	<input type="checkbox"/>	<input type="checkbox"/>	<input type="checkbox"/>
<b>09</b> black	<b>(nothing)</b> pad printed	<b>136</b> ▲	<b>118</b> OK	<b>06</b> white
<b>16</b> frosted white	<b>LMH</b> hard paint laser marked		<b>123</b> ☺	<b>09</b> black
	<b>M</b> Metal		***Find more options on apem.com	

\*optional, \*\* 2.0N actuation force not recommended for controlmec

Ordering example:  
 95CB358216LMH13611809 - illuminated non-sealed controlmec  
 95CC650913612306 - non-illuminated panel sealed controlmec  
 95NB358216LMH13611809 - illuminated Navimec module  
 95QB200116M118 - illuminated 10Q module  
 95RA350912306 - non-illuminated 10R module

Please see colour codes, updates of products and changes of specifications on [www.apem.com](http://www.apem.com)

## RoHS Compatible

	HIGH TEMPERATURE VERSIONS		
	SILVER	GOLD	NC/NO
<b>ELECTRICAL SPECIFICATIONS</b>			
Contact resistance	<30m Ω - typ. 10m Ω		
Insulation resistance	>10M Ω		
Recommended load	0.5-50mA 24VDC	0.5μ-50mA 24VDC	
Contact bounce	<2mS - typically 0.5mS		
<b>MECHANICAL SPECIFICATIONS</b>			
Standard actuation force (switch)	2.0N, 3.5N, 6.5 N		3.5N
Max. Actuation force without cap	115N for 60 sec	(according to MIL-PRF-22885H)	100N for 10 sec
Key travel (switch)	1 mm		
Life time (switch)	>10,000,000 cycles		>1,000,000 cycles
<b>TEMPERATURE RANGE</b>			
Working temperature	Min -40°C Max +160°C		
Storage temperature	Min -40°C Max +160°C		
5G with LED (working & storage temp)	Min -30°C Max +85°C		
Soldering (through-hole switch)	IEC 60068-2-20 8:		
	Infrared, vapour phase, wave - max 240°C for max 40 sec or max 260°C for max 30 sec.		
	Soldering iron - max 350°C for max 3 sec.		
	Flux tight.		
<b>SOLDERING (SMD)</b>	JEDEC J-STD-020E		
<b>ENVIRONMENTAL ENDURANCE IEC 68-2-3</b>			
Temperature	+40°C		
Humidity	93% RH		
Duration	56 Days		
<b>TEMPERATURE CYCLING IEC 68-2-14</b>			
Temperature limit	Min -55°C - Max +85°C		
Number of cycles	200		
Exposure time at each temperature	10 min		
Recovery time before measurements	16 hrs		
Sealing IEC 529	IP-67		
Cleaning	Standard methods - see usage guidelines		
<b>MATERIAL SPECIFICATIONS - SWITCHES</b>			
Housing	PPS UL94V0		
Actuator	PPS UL94V0		
Sealing + spring	Silicone rubber		
Contact spring	Stainless steel		Stainless steel
	+ 3μAg		+ 1μAu
Fixed contacts	SnCu + 2μNI + 3μAg	SnCu + 2μNI + 1μAu	
Terminals	SnCu + 2μNI + 3μSn100		

## Caps, Bezels & Legends – Material Specifications

MATERIAL	PARTS	TEMP. LIMIT	UL RATING
ABS	1A, 1B, 1C, 1DS, 1ES, 1FS, 1H, 1JS, 1KS, 1LS, 1M, 1NS, 1PS, 1QS, 1RS, 1TS, 1US, 1VS, 1WAS, 1WDS, 1WPS, 1XS, 1Z, 1ZA, 1ZB, 1ZCS, 1ZW, 2C, 2D, 2K, reflectors for 1KBS/1KCS and 1YS	Max. 65°C	UL94HB
Polycarbonate	All lenses and transparent colour caps, lids for 1KBS/1KCS	Max. 85°C	UL94HB
Polyamide	1GAS/1GCS, 1SS, 2SS	Max. 160°C	UL94V2
Legends Adhesion	DS/EN ISO 2409 Class 1 & ASTM D3359 Class 4B		

## RoHS Compatible

		HIGH TEMPERATURE VERSIONS	
		SILVER	GOLD
<b>ELECTRICAL SPECIFICATIONS</b>			
Contact resistance	<30m Ω - typ. 10m Ω		
Insulation resistance	>10M Ω		
Recommended load	0.5-50mA 24VDC	0.5μ-50mA 24VDC	
Contact bounce	<2mS - typically 0.5mS		
<b>MECHANICAL SPECIFICATIONS</b>			
Standard actuation force (switch)	3.5N typ		
Max. Actuation force without cap	100N for 10 sec		
Key travel (switch)	1 mm		
Life time (switch)	>10,000,000		
Temperature Range			
Working temperature	Min -40°C Max +160°C		
Storage temperature	Min -40°C Max +160°C		
Soldering IEC 60068-2-20 8 :	Infrared, vapour phase, wave - max 240°C for max 40 sec or max 260°C for max 30 sec. Soldering iron - max 350°C for max 3 sec. Flux tight.		
<b>ENVIRONMENTAL ENDURANCE IEC 68-2-3</b>			
Temperature	+40°C		
Humidity	93% RH		
Duration	56 Days		
<b>TEMPERATURE CYCLING IEC 68-2-14</b>			
Temperature limit	Min -55°C - Max +85°C		
Number of cycles	200		
Exposure time at each temperature	10 min		
Recovery time before measurements	16 hrs		
Sealing IEC 529	IP-67		
Cleaning	Standard methods - see usage guidelines		
<b>MATERIAL SPECIFICATIONS - SWITCHES</b>			
Housing	PPS UL94V0		
Actuator	PPS UL94V0		
Sealing + spring	Silicone rubber		
Contact spring	Stainless steel	Stainless steel	
	+ 3μAg	+ 1μAu	
Fixed contacts	SnCu + 2μNI + 3μAg	SnCu + 2μNI + 1μAu	
Terminals	SnCu + 2μNI + 3μSn100		

## Caps – Material Specifications

MATERIAL	PARTS	TEMP. LIMIT	UL RATING
Polyamide	Actuators for varimec™	Max 160°C	UL94V2

### LEDs specifications

#### 5G switches

Colour		Blue	Green	Yellow	White	Red	High Intensity Green
Colour Codes		02	22	42	61	82	29
<b>ABSOLUTE MAXIMUM RATINGS (Ta=25°C)</b>							
Power	mW	95	75	60	48	65	102.5
Current forward	mA	25	30	25	15	25	25
Forward peak current	mA	100	80	60	100	100	150
Voltage reverse	V	5	5	5	NA	12	5
Operating temperature	°C	-40/+85	-55/+85	-40/+85	-40/+85	-30/+85	-40/+85
Storage temperature	°C	-40/+90	-55/+85	-40/+90	-40/+85	-40/+85	-40/+85
Soldering temperature	°C	245 for max. 10 sec					
<b>ELECTRICAL-OPTICAL CHARACTERISTICS (Ta=25°C)</b>							
Voltage forward	Typ. V	3.3	2	1.75**	2.85	2	3.3
	Max. V	3.7	2.4	2.35	3.1	2.5	4.1
Current reverse (VR=5V)	Max. µA	50	100	10	NA	100	50
Wave length	nm	470	571	591	NA	633	525
Spread	Δnm	25	NA	15	NA	16	30
Spread angle	degree	120	130	120	150	160	60
<b>Luminous Intensity</b>	Min. mcd	45	18	28.5	71	28	500
	Typ. mcd	112*	35	72*	224*	180*	1000
Optical intensity	Lm/w	NA	NA	NA	36	7	NA

\*Max.mcd \*\*Min. V

#### 3F switches

#### 3FXXX (for 1E-1F-1N-1Q-1R-1S-1X)

#### 3FXXX (for 1K-1T-1U-1V-1W-1WD)

Colour		B	G	Y	W	R	G/Y	R/G	R/Y	G	Y	R	
Colour Codes		00	20	40	65	80	2040	8020	8040	24	46	87	
<b>Absolute Maximum Ratings</b>	(Ta=25°C)												
Power	mW	105	70	60	120	60	120	100	120	60	60	120	
Current forward	mA	30	20	20	25	20	25	30	25	25	25	50	
Forward peak current	mA	150	60**	60**	100	60**	150	120	150	60	60	200	
Voltage reverse	V	5	3	3	5	3	5	5	5	5	5	5	
Operating temperature	°C	-40/+85			-40/+85	-25/+85	-40/+85	-55/+100	-40/+85	-40/+85	-40/+85	-40/+85	
Storage temperature	°C	-40/+85			-40/+100	-30/+100	-40/+85	-55/+100	-40/+85	-40/+85	-40/+100	-40/+100	
Soldering temperature	°C	260 for max 5 sec					260 for max 2 sec			300 for max 3 sec		260 for max 5 sec	
<b>Electrical-Optical Characteristics (Ta=25°C)</b>													
Voltage forward	Typ. V	3.8	2.1	2.1	3.8	2.0	2.1	2.0	2.1	2.0*	2.0	2.0***	
	Max. V	4.5	3.0	3.0	4.3	3.0	2.8	2.6	2.8	2.4*	2.4	2.4***	
Current reverse (VR=5V)	µA	10	10	10	50	10	2	2	2	10	10	10	
Wave length	nm	466	563	585	NA	650	565/590	630/565	625/590	570	589	624/632	
Spread	Δnm	60	40	40	NA	40	35	35	35	10	NA	20	
Spread angle	degree	60	45	45	25	45	60	200	60	100	40	40	
<b>Luminous Intensity</b>	Min. mcd	18	9.0	5.6	630	5.6	8	2.2	8	70****	630	400****	
	Typ. mcd	50	25	16	1000	16	25	4.8	25	20****	1250	800****	
Orientation	The longer pin is the anode, the shorter is the cathode. For bicolour LEDs the anode for the first colour (ex. 2080) is the longer pin.												

\*\*Pulse width 1ms Duty cycle 1:5, \*\*\*/F =50mA, \*\*\*\* Luminous Flux mlm

B=Blue, G=Green, Y=Yellow, R=Red, W=White

Specifications are subject to change without notice.

Specifications are subject to change without notice.

For product updates and/or changes of specifications please see [www.apem.com](http://www.apem.com)

## 2 POLE SWITCH

MOMENTARY AND LATCHING FUNCTION

ADJUSTABLE TO MULTIMEC® CAP RANGE



unimec™ product range has high temperature switches with square- or rectangular-shaped cap solutions.

unimec™ switches have 8 contact function options making it very flexible and suitable for any application.

Redundancy coming from the number of poles makes it an excellent choice where safety is a concern.



- Square solution
- 15.1mm x 15.1mm
- h=20.5 mm
- Material: ABS
- Temp. Range: -40/+65°C

All dimensions in mm

Tolerances +/-0.2mm

### DIMENSIONS

(TH) + 16324

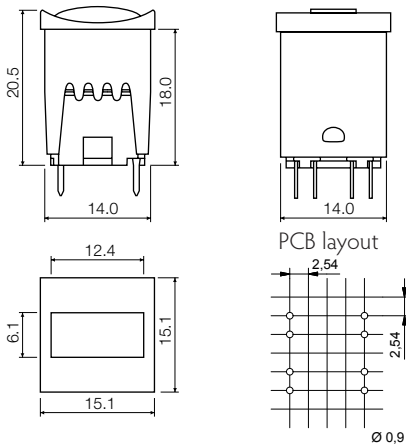

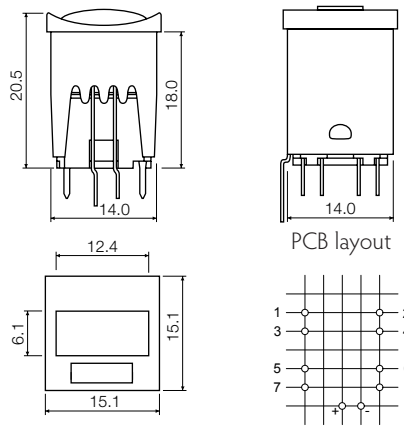

(TH w/LED) + 16325



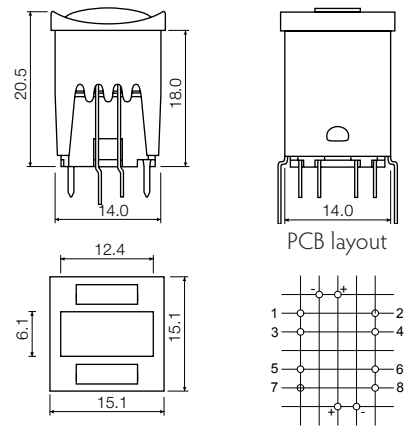





(TH 2 w/LED) + 16326



### NON-ILLUMINATED - HOW TO ORDER

Switch		Extender		Cap		Bezel
<b>1 5 4</b>	+	<b>1 6 2 7 0</b>	+	<b>1 6 3 0 0</b>	+	<b>1 6 3 2 4</b>
15401 mom. silver				00 blue		03 grey
15402 mom. gold				02 green		09 black
15420 silent gold				03 grey		
15451 lat. silver				04 yellow		
15452 lat. gold				06 white		
				08 red		
				09 black		

### ILLUMINATED - HOW TO ORDER

Switch		Extender		Cap		Bezel		Lens		LED
<b>1 5 4</b>	+	<b>1 6 2 7 0</b>	+	<b>1 6 3 0 0</b>	+		+	<b>1 6 3 2 7</b>	+	<b>1 6 9 2 2</b>
						<b>16325</b>		02 green		02 green
								04 yellow		04 yellow
						<b>16326</b>		08 red		08 red
								Lens <b>16327</b>		LED <b>16922</b>
								2 required		2 required
										

Ordering example: 15451+16270+1630004+1632403 (non-illuminated) OR 15401+16270+1630008+1632509+1632708+1692208 (illuminated)  
 Please see colour codes, updates of products and changes of specifications on [www.apem.com](http://www.apem.com)

- Square solution
- 15.1mm x 15.1mm
- h=16.0 mm
- Material: ABS
- Temp. Range: -40/+65°C

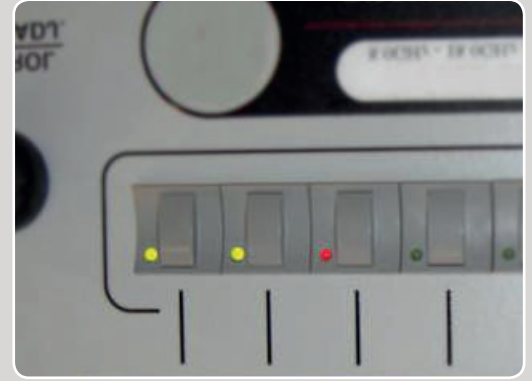

All dimensions in mm

Tolerances +/-0.2mm

### DIMENSIONS

(TH) + 16310

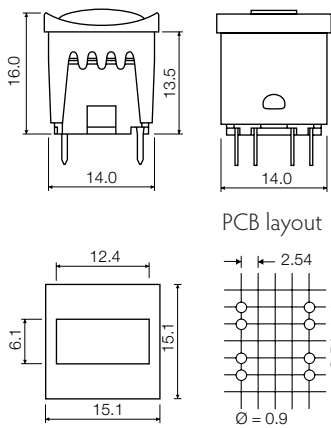

(TH w/LED) + 16311

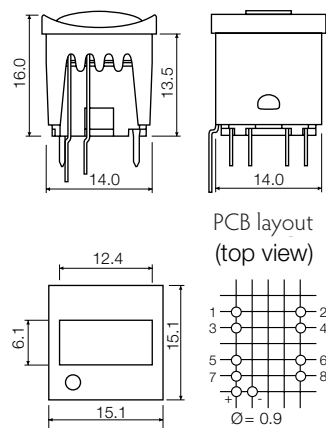

(TH w/LED) + 16312

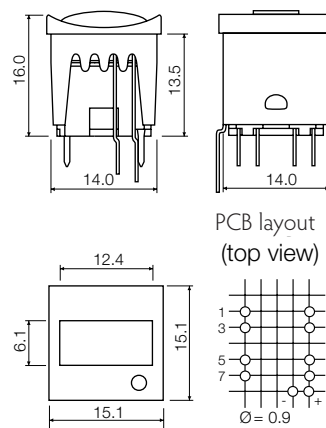

(TH w/4 LED) + 16315

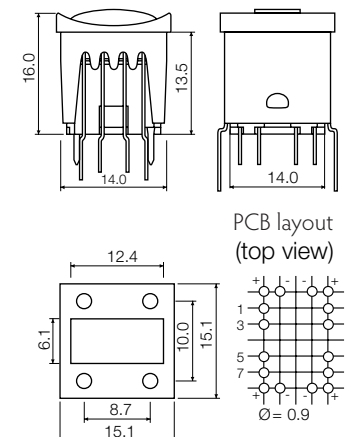

### NON-ILLUMINATED - HOW TO ORDER

Switch

1 5 4

- 15401 mom. silver
- 15402 mom. gold.
- 15420 silent gold
- 15451 lat. silver
- 15452 lat. gold

+

Cap

1 6 3 0 0

- 00 blue
- 02 green
- 03 grey
- 04 yellow
- 06 white
- 08 red
- 09 black

+

Bezel

1 6 3 1 0

- 03 grey
- 08 red
- 09 black

Additional colours for 16310 only:

- 00 blue
- 02 green
- 04 yellow
- 06 white

### ILLUMINATED - HOW TO ORDER

Switch

1 5 4



+

Cap

1 6 3 0 0



+

Bezel

16311



16312



16314



16315

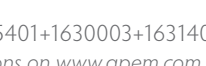

+

LED

1 6 9 2 1

- 02 green
- 04 yellow
- 08 red

+

1 6 9 2 0

- 02 green
- 04 yellow
- 08 red

+

LED 16920 1 required LED 16921 1 required

+

LED 16920 2 required LED 16921 2 required



Ordering example: 15400+1630002+1631002 (non-illuminated) OR 15401+1630003+1631408+1692008+1692108 (illuminated)

Please see colour codes, updates of products and changes of specifications on [www.apem.com](http://www.apem.com)



- Square and rectangular caps
- 6mm x 12.3mm; 14.9mm x 14.9mm; 15.1mm x 15.1mm
- h=16.9mm; 14.6mm; 14.5mm
- Material: ABS
- Temp. Range: -40/+65°C

All dimensions in mm

Tolerances -/+0.2mm

### DIMENSIONS

(TH) + 16300

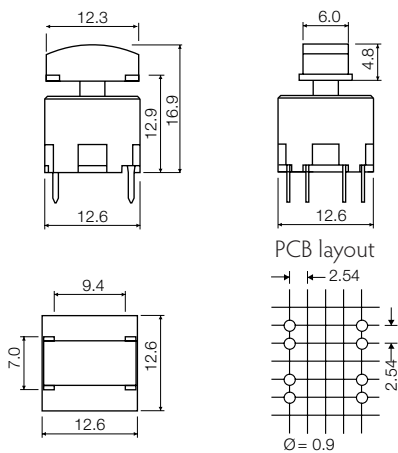

(TH) + 16700

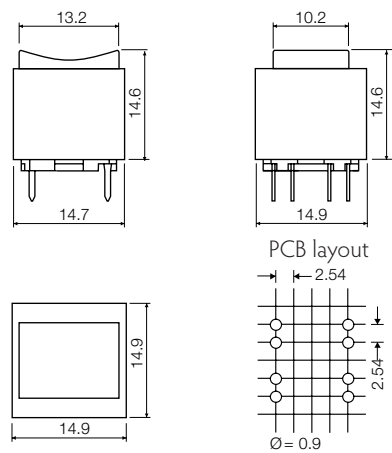

(TH) + 16800

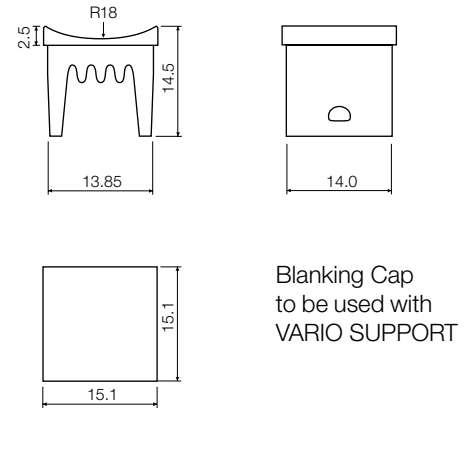

Blanking Cap  
to be used with  
VARIO SUPPORT

### NON-ILLUMINATED- HOW TO ORDER

Switch

1 5 4

- 15401 mom. silver
- 15402 mom. gold.
- 15420 silent gold
- 15451 lat. silver.
- 15452 lat. gold

Cap and color code

+ 1 6 3 0 0



- 00 blue
- 02 green
- 03 grey
- 04 yellow
- 06 white
- 08 red
- 09 black

Switch

1 5 4



Cap

+ 1 6 7 0 0



- 00 blue
- 02 green
- 03 grey
- 04 yellow
- 06 white
- 08 red
- 09 black

Ordering example: 15451+1630003 OR 15401+1670008

Please see colour codes, updates of products and changes of specifications on [www.apem.com](http://www.apem.com)



Standard legends are marked with red.

All standard legends are white on black caps.

The size of the legends listed may not correspond to the actual size. Please ask your local distributor, if you do not find what you need on the list. New legends may have been added after this catalogue was printed.

Custom legends and other colour combinations are available, please contact your local distributor.

### Available Legends

Part no.			Part no.			Part no.		
LEGEND	18_	18_	LEGEND	18_	18_	LEGEND	18_	18_
0	000	200	A	010	210	ON/OFF	017	217
1	001	201	B	011	211	STOP	018	218
2	002	202	C	012	212	START	031	231
3	003	203	D	013	213	CLEAR	036	236
4	004	204	E	014	214	LOAD	037	237
5	005	205	F	015	215	RESET	038	238
6	006	206	G	063	263	CR	043	243
7	007	207	H	064	264	MANUAL	044	244
8	008	208	I	065	265	END	047	247
9	009	209	J	066	266	CANCEL	048	248
10	020	220	K	067	267	CTRL	050	250
11	021	221	L	068	268	ESC	051	251
12	022	222	M	069	269	DSP	053	253
13	023	223	N	070	270	ENTER	105	305
14	024	224	P	072	272	SHIFT	106	306
15	025	225	S	075	275	ON	116	316
16	026	226	T	076	276	OFF	117	317
			U	077	277			
			V	078	278			
			W	079	279			
			#	107	207			
			*	019	219			
			☐	016	216			
			→	033	233			
			←	133	233			
			↑	034	234			
			↓	134	234			
			↙	135	235			
			↕	115	215			
			↔	041	241			
			+	054	254			
			-	059	259			
			•	056	256			
			:	055	255			

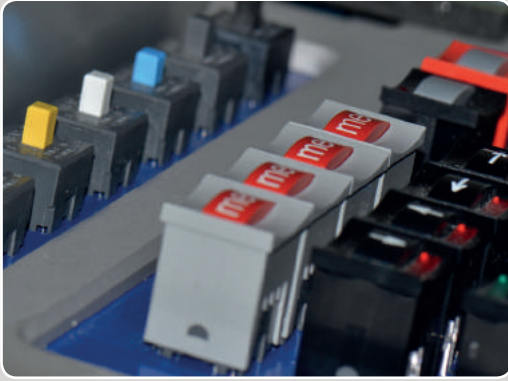

- Max. 250mA/120V/9W AC/6W DC
- 2 pole
- Momentary or latching
- 8 contact functions
- Temperature range:  
High temp: -40/+160°C
- Through-hole version (TH)

All dimensions in mm

Tolerances +/-0.2mm

### DIMENSIONS THROUGH-HOLE

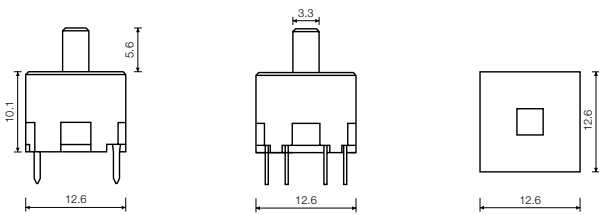

### OPERATING FORCE (TYPICAL EXAMPLE)

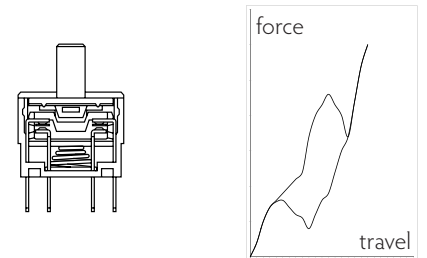

### PCB MOUNTING HOLE DIMENSIONS

### FUNCTIONAL DIAGRAM

### CIRCUIT DIAGRAM

Basic switch

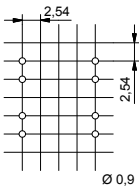

w/Extender 16250

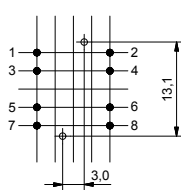

With LED

16923 and 16924

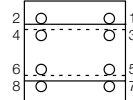

— up  
-- down

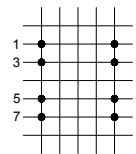

Without LED

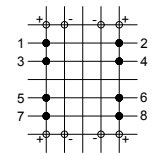

With round LED  
16920 and 16921

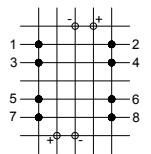

With rect. LED  
16922

### WIRING DIAGRAM

Select the contact function you require - and design your PC board accordingly

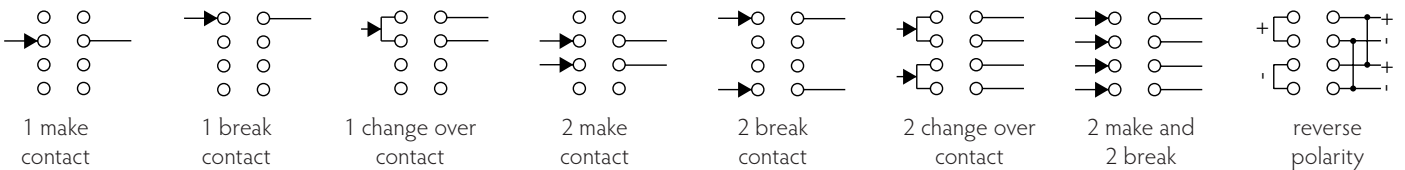

### HOW TO ORDER

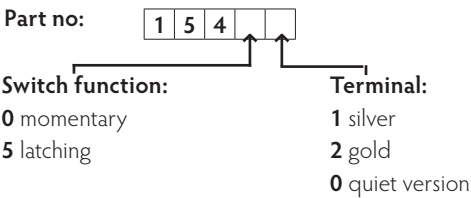

High temp.

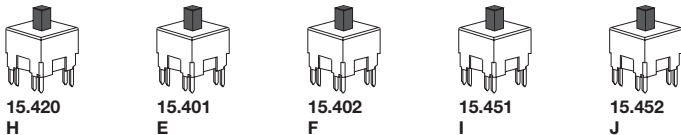

### HOW TO ASSEMBLE

unimec™  
15XXX+16300 +16310



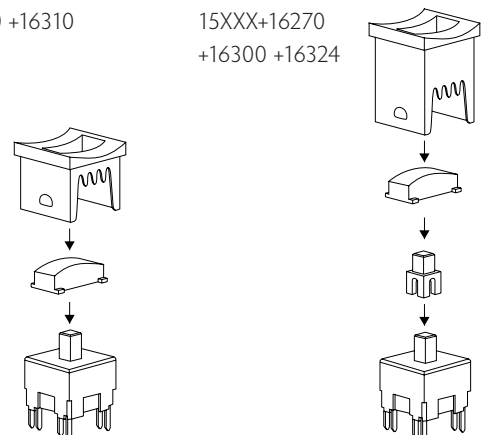



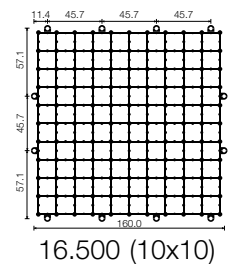
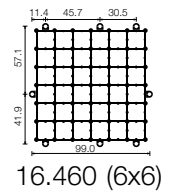
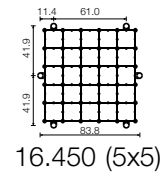
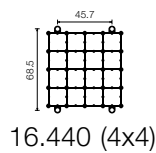
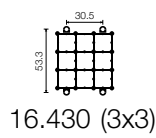
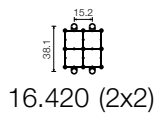
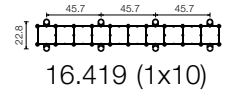
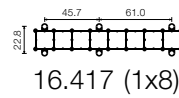
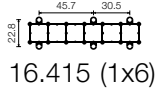
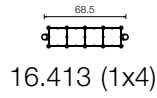
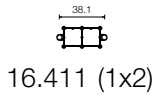
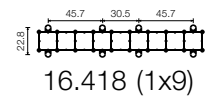
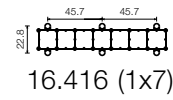
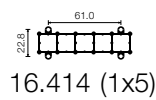
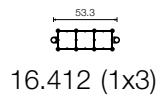
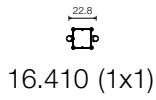
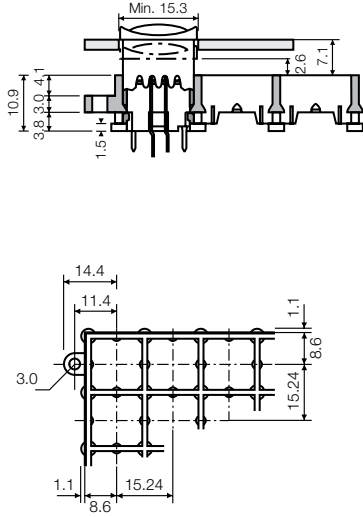









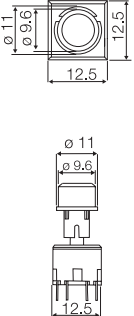
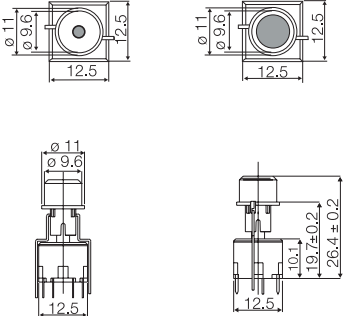
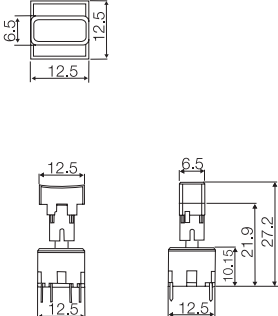
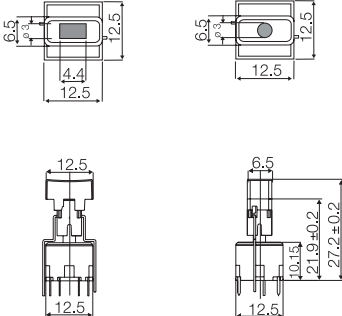

unimec™  
15XXX+16270  
+16300 +16324

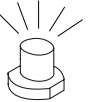

For all types of unimec™ switches with bezels - 16310 - 16315 and 16324 - 16326.  
More options available as custom.

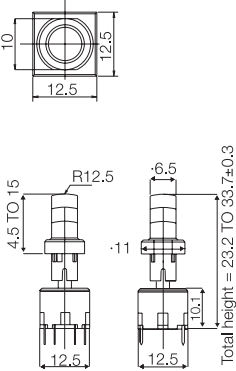
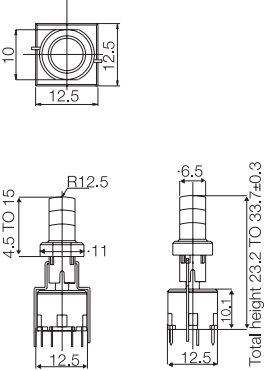
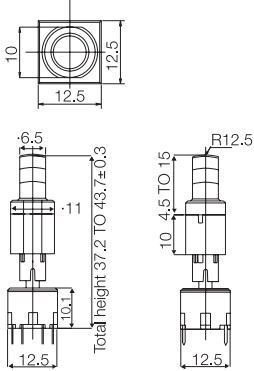
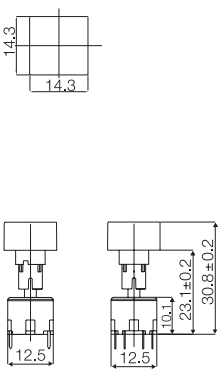

## Selection guide

 <b>A 16250 extender is needed when mounting multimec® on unimec™ switches</b>					
<b>Cap</b>  1D	 1E  1F	 1P	 1Q  1R		
<b>Dimensions</b> 					
<b>LED</b>	<b>16923XX</b> 00 blue  20 green 40 yellow 65 white 80 red		<b>16923XX</b> 00 blue  20 green 40 yellow 65 white 80 red		
<b>Cap</b>  1S	 1S illuminated	 1S + 2S	 1K  1K illuminated		
<b>Dimensions</b> 					
<b>LED</b>	<b>16923XX</b> 00 blue  20 green 40 yellow 65 white 80 red	<b>16923XX</b> 00 blue  20 green 40 yellow 65 white 80 red	<b>16924XX</b>  23 green 45 yellow 88 red		

For specific dimensions, color codes, how to order and other information please refer to the pages with the keycaps on multimec® switches. For technical information on the unimec™ basic switches please see technical specifications or go to our website [www.apem.com](http://www.apem.com) where you will find a page for each option. The multimec® keycaps 1N, 1T, 1U, 1V, 1WA, 1WD, 1WP and 1X can also be used on unimec™ switches. Please ask for technical drawings on dimensions.

## RoHS Compatible

		RA	
		High Temperature Versions	
		Silver	Gold
<b>Electrical Specifications</b>			
Contact resistance		Max. 100 m Ω (initially)	
Insulation resistance		>10 M Ω	
Recommended load		Min. 0.5 mA	Min. 0.5 μA
		Max. 250 mA – 120 V – 9W AC – 6W DC	
Max. Current in non switching state		0.5 A	
Contact bounce		Max. 10 ms	
Dielectric strength between adjacent contacts		1000 V for 2 min.	
Insulation resistance between adjacent contacts		5 X 10 <sup>13</sup> Ω	
Capacitance between adjacent contacts		0.5 pF	
<b>Mechanical Specifications</b>			
Standard actuation force (switch)		Typ 2.5N	
Max. Actuation force without cap		100N for 10 sec.	
Key travel (switch)		1.8 mm	
Lifetime	Momentary	>10.000.000 cycles	
	Latching	5.000.000 cycles	
<b>Temperature range</b>			
Working temperature		Min. -40°C Max. +160°C	
Storage temperature		Min. -65°C Max. +160°C	
<b>Soldering IEC 68-2-20</b>			
		Wave – max 260°C for max. 10 sec., please refer to usage guidelines	
		Soldering iron – max. 350°C for max. 3 sec. Flux tight.	
<b>Environmental Endurance IEC 68-2-3</b>			
Temperature		+40°C	
Humidity		93% RH	
Duration		56 days	
Sealing IEC 529		IP-54	
Cleaning		Standard methods such as water and soap (not immersed)	
<b>Material Specifications – Switches</b>			
Housing and actuator		LCP UL94V0	
Switch spring		Stainless steel	
Key spring		Stainless steel	
Latch pin		Stainless steel	
Fixed contact		SnCu+2μNi+3μAg	SnCu+2μNi+3μAu
Moving contact		Stainless steel +3μAg	Stainless steel +3μAg+1μAu
<b>Terminals</b>			
Contact lubricant		Special protective lubricant Klüber Barrierta I EL Fluid	
<b>Material Specifications – All Caps &amp; Bezels</b>			
Temperature limit		Max. +65°C	
<b>Tampon Printing</b>			
		According to ISO Class: 1/ASTM Class:4B	

## unimec™ LEDs

Part Nos.	16920/16921			16922			16923					16924			
Colour (G=green, Y=yellow, R=red)	G	Y	R	G	Y	R	B	G	Y	W	R	G	Y	R	
Colour Codes	02	04	08	02	04	08	00	20	40	65	80	23	45	88	
Absolute Maximum Ratings (Ta=25°C)															
Power	mW	100	100	100	135	135	135	105	70	60	120	60	150	130	300
Current forward	mA	30	30	30	30	30	30	30	20	20	25	20	40	40	90
Forward peak current	mA	50	50	50	90	90	90	200	60**	60**	100	60**	500	500	1000
Voltage reverse	V	5	5	5	5	5	5	5	3	3	5	3	12	12	5
Operating temperature	°C	-25 - +100			-55 - +100			-25 - +85					-55 - +100		
Storage temperature	°C	-25 - +100			-55 - +100			-30 - +100					-55 - +100		
Soldering temperature	°C	+245 for max. 3 sec			+300 for max. 3 sec			+260 for max. 5 sec					+300 for max. 3 sec		
Electrical-Optical Characteristics (Ta=25°C)															
Voltage forward	Typ. V	2.0	2.0	2.0	2.1	2.2	2.3	2.1	2.1	2.1	3.8	2.0	2.1*	2.3***	2.4***
	Max. V	3.0	3.0	3.0	3.0	3.0	3.0	2.8	3.0	3.0	4.3	3.0	2.5*	2.5***	3.8***
Current reverse	μA	100	100	100	100	100	100	2	10	10	50	10	10	10	
Wave length	nm	560	590	660	565	585	635	460	563	585	NA	650	570	587	635
Spread	Ønm	10	10	10	10	10	10	40	40	40	NA	40	25	45	45
Spread angle	Degree	20	20	20	45	45	45	20	45	45	25	45	80	90	55
Luminous Intensity	Min. mcd	1	1	0.8	1.5	2.5	2.5	20	9.0	5.6	630	5.6	71****	71****	100****
	Typ. mcd	2	3	1.6	2.5	3.0	5.0	25	25	16	1000	16	112****	112****	160****
Orientation		The longer pin is the anode, the shorter is the cathode.													

\*F=20mA, \*\*Pulse width 1ms Duty cycle 1:5, \*\*\*F=50mA, \*\*\*\*Luminous Flux mlm

## WE WELCOME ANY CUSTOM REQUIREMENT

The wide range of MEC standard products is well known world wide, but also many custom solutions have been created. Equipped with the latest CAD solutions with 3D facilities and optical simulation software our experienced MEC team can provide you custom designs from conception to completion. Our R&D engineers generate computer animated solutions, rapid prototypes and manage the whole industrialisation process.



## CUSTOM SWITCHES

- ACTUATION FORCE
- TERMINALS
- TRAVEL

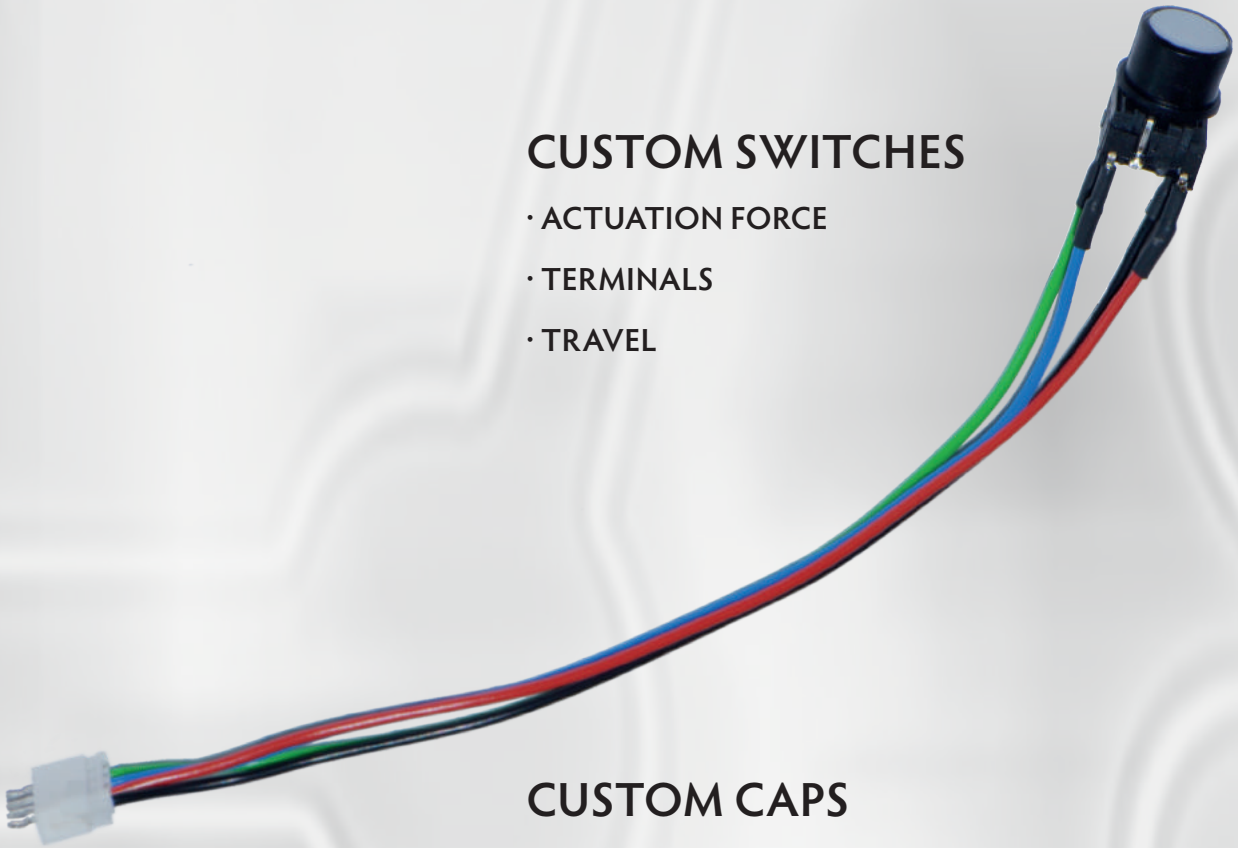

## CUSTOM CAPS

- DESIGN
- SHAPE
- SIZE
- COLOUR
- LEGENDS

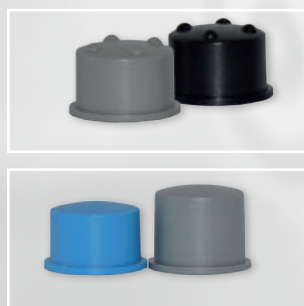
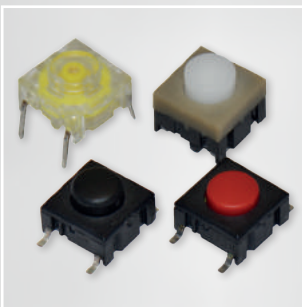























No.	00		02		03		04		06		08		09	
Colour	blue		green		grey		yellow		white		red		black	
RAL Code	5012		6018		7004		1023		9010		3000		9004	

No.	30		32		33		34		38		40		42	
Colour	ultra blue		mint green		tele grey		melon		noble red		dusty blue		aqua blue	
RAL Code	5002		6029		7046		1028		3002		5014		5021	

## Metallic Colours

No.	50		53		57		58	
Colour	dark blue		light grey		dark grey		bordeaux	
RAL Code	No Ral Code		No Ral Code		No Ral Code		No Ral Code	

CAP CODE		00	02	03	04	06	08	09	30	32	33	34	38	40	42	50	53	57	58
1A		•	•	•	•	•	•	•											
1B		•	•	•	•	•	•	•											
1C				•			•	•											
1DS		•	•	•	•	•	•	•	•	•	•	•	•	•	•	•	•	•	•
1ES/1FS		•	•	•	•	•	•	•											
1GAS/1GCS		•	•	•	•	•	•	•											
1H				•				•											
1JS		•	•	•	•	•	•	•											
1KS		•	•	•	•	•	•	•											
1M		•	•	•	•	•	•	•											
1NS				•				•											
1PS		•	•	•	•	•	•	•											
1QS/1RS		•		•				•											
1SS/1LS		•	•	•	•	•	•	•											
1TS/1US/1VS		•		•			•	•											
1WAS/1WDS/1WPS		•		•			•	•	•					•	•		•	•	
1XS		•	•	•	•	•	•	•											
1ZA				•		•		•	•					•	•	•	•	•	•
1ZB				•		•		•	•					•	•	•	•	•	•
1ZCS				•		•		•	•	•				•	•	•	•	•	•
1Z/1ZW		•		•		•		•											
10R/10RF + 10Q		•	•	•	•	•	•	•											

# Usage guidelines

## How to get the best results with MEC Switches?

These guidelines are offered to users of MEC Switches as an aid to ensure successful and reliable switch operation.

### Temperature

Both unimec™ and multimec® switches are produced in low and high temperature versions. Please see the technical specifications for details on operating and storage temperatures and soldering guidelines to make sure you select the best switch for your application. When wave soldering is taking place, MEC strongly recommend that the temperature profile is analysed and compared with the temperature rating of the switch. In case of doubt always select the high temperature versions unimec™ 154XX, and multimec® 5XXH9XX. It is also important to monitor the accumulated heat build up from both the pre-heat zones and the solder zone.

Most standard accessories for both unimec™ and multimec® switches are made from ABS plastic with a maximum operating temperature of 65°C. It is strongly recommended that accessories are mounted after soldering of the switch. If this is not possible care must be taken not to overheat the accessories during the soldering process. The 1SS, 1GAS/1GCS and Varimec™ caps are, however, made of high temperature materials and will meet the same temperature specifications as the high temperature switches.

For accessories made from other plastic materials please see multimec® and unimec™ technical specifications.

LEDs have their own temperature specifications. When fitted in a high temperature switch the LED will determine the max. operating temperature, i.e. 5GTH93524 has an upper temperature limit of 85°C! This also applies with 3F switches.

### Mounting and Dismounting

If switches are to be mounted in rows it is essential that the recommendations regarding spacing are followed. PC board thickness should be 1.4±0.2 mm and terminal hole diameter should be 0.9mm.

All unimec™ and multimec® caps and bezels are easily snapped onto the switch modules and can be changed at a later time with the exception of the unimec 16.700 cap. The same applies to the 3E caps. Once these caps are installed they are not designed to be removed. To do so may cause damage to the switch and the PC board if not done very carefully. If the 16.300 or 16.700 cap must be removed from a unimec™ alternate action switch, make sure that the switch actuator is in the released, upper position before attempting to remove the cap. This will prevent possible damage to the internal latching pin.

Care must be taken when inserting the 3FT switch and LED assembly into the PC board. Do not press direct on the LED. This will force the LED down into the actuator and risks to cause the switch contacts to remain in the closed position. To correct the fault, the LED must be raised slightly and centered in the actuator to assure unrestricted movement of the actuator. A mounting tool is available for multimec® switches.

### Soldering and Cleaning unimec™

Most assembly and field problems experienced by users of unsealed switches are caused by the contamination of the contacts during soldering and cleaning.

Contact contamination may be recognised by an increase in contact resistance and possible intermittent operation of the switch, especially in low power applications. Care must be taken not to submerge the switch in cleaning agents or spray the switch during cleaning. The switch must be protected at all times to prevent contamination by flux or cleaning liquids.

For unimec™ alternate versions we recommend to leave the actuator in the released upper position during soldering. This makes the switch more resistant to overheating.

### Soldering and Cleaning multimec®

multimec® switches are fully sealed to IP67 specifications to prevent solder flux and aqueous based cleaning solutions from entering the switch and contaminating the contacts. The switches can be placed on the PC board with other components and wave soldered. multimec® offers a high level of sealing, however, with aqueous solvent solutions care must be taken to avoid the worst case situation with water jets, complete immersion into a liquid with a temperature below the board or surface tension reducing additives.

Recommended cleaning methods are demineralized water. Any surface tension reducing agents, such as soap, must not be used as they risk causing a potential leakage of the switch.

### Soldering - Through Hole Versions

Hand soldering: Max. 350°C for max. 3 sec., this applies for both low temperature and high temperature versions.

Wave soldering: heat built up in the switch during pre-heating and soldering must not exceed the maximum operating temperature of the switch. If, for some reason, a high pre-heating temperature is required, MEC recommend the high temperature switches. In any case peak temperature must not exceed 260°C, and soldering time is max 10 sec.

### Soldering - Surface Mount Versions

For all methods - infrared, convection and vapour phase. The upper limit 260°C/30 sec must be observed. The soldering temperature profile must have moderate temperature gradients.

### RoHS Compliance

As of 1 July 2006 MEC has completed the conversion to RoHS compliance. For more info please see our homepage [www.apem.com](http://www.apem.com)

### Temperature Limits:

Low temperature switch	115°C
High temperature switch	160°C
LEDs	85/100°C
Accessories	65/85/160°C

### Packaging

unimec™ and multimec® switches are packed in rigid tubes of 50 pieces each.

A box contains 1.000 pcs.

The surface mount versions of multimec® switches with a height up to 12.5mm can also be delivered on tape/reel. Each reel contains 250/500 pcs.



MEC A/S  
Industriparken 23  
2750 Ballerup, Denmark  
Phone: +45 44 97 33 66  
E-mail: danmec@mec.dk

Please visit our website [www.apem.com](http://www.apem.com)  
for news and product updates

# Mouser Electronics

Authorized Distributor

Click to View Pricing, Inventory, Delivery & Lifecycle Information:

## Apem:

[1692002](#) [1692008](#) [1692202](#) [1692208](#) [1ES001](#) [1GAS09](#) [1JS11](#) [1PS06](#) [1PS09](#) [1QS031](#) [2S09-06.0](#) [2S09-07.0](#)  
[1UW](#) [1TW](#) [1VW](#) [1US16](#) [1VS16](#) [1GA09](#) [1N10](#) [1FS036](#) [1TS08](#) [1D40](#) [1N16](#) [1V03](#) [1K1116](#) [1F001](#) [1N12](#) [1Q091](#)  
[1F098](#) [2S09-10.0](#) [1VS08](#) [2D138](#) [1D09](#) [1F092](#) [1N00](#) [1D04](#) [1N14](#) [1U16](#) [1U08](#) [1M00](#) [1K00](#) [1TS09](#) [2S09-05.0](#)  
[1D58](#) [1X16](#) [1D08](#) [1T03](#) [1D53](#) [1X40](#) [1S09-22.5](#) [1QS096](#) [1D33](#) [1S09-19.0](#) [1JS09](#) [1S11-16.0](#) [1S09-16.0](#) [1T16](#)  
[1P03](#) [1D02](#) [1M06](#) [1D11](#) [1U03](#) [1Z09](#) [1R036](#) [1Z09136118](#) [1N03](#) [1PS11](#) [1U09](#) [1WA53](#) [1D42](#) [1D38](#) [1KC1116](#)  
[1US08](#) [1D16](#) [1D03](#) [1FS096](#) [1ES096](#) [1V16](#) [1WA40](#) [1E094](#) [2S09-09.0](#) [1PS00](#) [1TS03](#) [1D32](#) [1WP40](#) [1ES086](#)  
[1WD40](#) [1E036](#) [1FS086](#) [1WA57](#) [1PS16](#) [1Q096](#) [1Q036](#) [1WP57](#) [1D50](#) [1E092](#) [1FS096123](#) [1RS036](#) [1WP08](#) [1T08](#)